

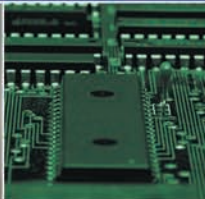

SAFETY CATALOG



Welcome to PowerPlus

PowerPlus is a nationally recognized supplier of safety, construction and environmental supplies. With our committed approach to service those industries that are truly designed to help and protect people we are extremely proud of our entry into the restoration and mold remediation industries... and as with other markets we serve, PowerPlus is rapidly becoming the leading supplier in the restoration and mold remediation industries.

We are confident this catalog will be a useful resource for our customers. The vast array of items included offer the latest state of the art products to fulfill every need for the professional restoration and remediation contractor. While we have included the latest product selections, we also realize in this exciting and growing industry there are many innovative products being introduced on a continuing basis. We have an experienced sales team to provide customers with information on the latest products that are available to the markets.

With this new updated catalog as a useful tool, our experienced and knowledgeable sales team, our extensive inventories, and our genuine commitment to service, we are committed to be the restoration contractor's "supplier of choice."

Mission Statement:

- We are problem solvers who profit from creating customer solutions
 - Our business focuses exclusively on fulfilling needs of the cleaning and decontamination industries.
 - We grow profitable by:
 - ENRICHING our clients' business
 - CREATING learning and growth for ourselves
 - DELIVERING these on a Biblical foundation of integrity.
-

- We grow profitable by:
 - ENRICHING our clients' business
 - We don't just sell the goods, we deliver the goods.
 - CREATING learning and growth for ourselves
 - We stay on the cutting edge in order to be leading contributors to our customers and community.
 - DELIVERING these on a Biblical foundation of integrity.
 - We walk the talk---our mouths match our moves.

How to Order

Simple Ordering Options:

- Call the nearest PowerPlus location listed at the bottom for fast, friendly and knowledgeable customer service.
- Fax orders to the nearest PowerPlus location.

Shop online at www.PowerPlusOnline.com



Table of Contents

Eye and Face Protection	5
Head Protection	12
Hearing Protection	15
Respiratory Protection	18
Hand Protection	44
Protective Clothing	58
Foot Protection	70
Fall Protection	73
Confined Space	85
Instrumentation	94
Ergonomics	100
First Aid	104
Traffic / Signs	111
Plant Maintenance	119
Construction Products	141
Environmental Products	156



Eye and Face Protection

BLACKJACK®



Crews BLACKJACK safety glasses feature a stylish wrap-around lens design with integral sideshields and offers durable metal alloy temples with non-slip rubber head-grips for a customized fit.



Part #	Description
CRWS2110	BlackJack®, Clear Lens*
CRWS2112	BlackJack®, Grey Lens*
CRWS2117	BlackJack®, Silver Mirror Lens
CRWS2119	BlackJack®, Indoor-Outdoor Lens

*ALSO AVAILABLE WITH DURAMASS® AF4 ANTI-FOG COATING

TOMAHAWK®

The TOMAHAWK features a stylish wraparound design, fully adjustable ratchet action temples and a one-piece polycarbonate lens with integral sideshields. The lightweight frame provides added comfort and balance.



Part #	Description
CRWTK110	Tomahawk®, Black Frame, Clear Lens
CRWTK110AF	Tomahawk®, Black Frame, Clear Lens Anti-Fog
CRWTK112	Tomahawk®, Black Frame, Grey Lens
CRWTK119	Tomahawk®, Black Frame, Indoor-Outdoor
CRWTK120	Tomahawk®, Blue Frame, Clear Lens
CRWTK122	Tomahawk®, Blue Frame, Grey Lens
CRWTK130	Tomahawk®, Red/White/Blue, Clear Lens
CRWTK132	Tomahawk®, Red/White/Blue, Grey Lens

TACOMA®

The TACOMA is a low cost high quality safety glass that provides safety, comfort and durability. Made of a strong, lightweight, scratch-resistant, polycarbonate, the one-piece wrap around lens delivers both a wide field of vision and maximum protection.



Part #	Description
CRWTC110	Tacoma®, Black Temple, Clear Lens
CRWTC112	Tacoma®, Black Temple, Grey Lens

FROSTBITE 2®

Crews took the coolest look in eye protection and squared it. The Frostbite 2® from Crews has a squared look of trend setting designer eyewear. Safety times style to the second power. The Frostbite 2 features Ultra-lightweight frames for comfort and the lenses also filter out 99.9 percent of UV radiation. Available in three frame colors with an indoor-outdoor lens.



Part #	Description
CRWF2110	Frostbite®, Black Frame, Clear Lens
CRWF2112	Frostbite®, Black Frame, Grey Lens
CRWF2117	Frostbite®, Black Frame, Silver Mirror Lens
CRWF2119	Frostbite®, Black Frame, Indoor-Outdoor Lens
CRWF2128	Frostbite®, Blue Frame, Blue Mirror Lens
CRWF2142	Frostbite®, Frost White Frame, Grey Lens

STORM®

Storm offers extreme comfort in a wraparound lens construction, plus the ratchet-action temples are combined with non-slip rubber head grips to create a customized fit. This popular style is lightweight and has scratch-resistant polycarbonate lens that filter out 99.9% of UV radiation. Meets ANSI Z87.1-1989.



Part #	Description
CRWST110	Storm®, Black Frame, Clear Lens
CRWST112	Storm®, Black Frame, Grey Lens
CRWST114	Storm®, Black Frame, Amber Lens
CRWST117	Storm®, Black Frame, Silver Mirror Lens
CRWST119	Storm®, Black Frame, Indoor-Outdoor Lens
CRWST120	Storm®, Navy Frame, Clear Lens
CRWST122	Storm®, Navy Frame, Grey Lens
CRWST128	Storm®, Navy Frame, Blue Mirror Lens
CRWST130	Storm®, Red Frame, Clear Lens
CRWST132	Storm®, Red Frame, Grey Lens

RATTLER®

Watch out, 'cause these striking metal frames are going to rattle a few cages! The RATTLER® unites ANSI safety standard protection with the look of trend-setting fashion eyewear and the durability of metal alloy frames. Uniquely designed to provide protection, comfort, and style, the Rattler is light in weight but heavy on safety. Non-slip rubber head-grips create a customized fit for virtually any head size. The Custom fit nose pad, made of soft, pliable PVC, is adjustable.



Part #	Description
CRWRT120	Rattler®, Chrome Frame, Clear Lens
CRWRT122	Rattler®, Chrome Frame, Grey Lens
CRWRT129	Rattler®, Chrome Frame, Indoor-Outdoor Lens

Eye and Face Protection

**New
Product**

INTRODUCING THE DEUCE®



TWO FORMS. ONE FUNCTION. PERFECT FIT.

When it comes to safety eyewear, two sizes are better than one. Deuce safety glasses from Crews are available in two sizes to provide a more comfortable, more accurate fit. Deuce safety glasses meet or exceed ANSI Z87.1 Safety Standard. Standard features include, Duramass AF-4 anti-fog coating, strong yet lightweight polycarbonate frame and lens, synthetic rubber nose piece provides soft comfortable fit and equipped with our non-slip rubber head grips.

Part #	Description
CRWDC110	Deuce®, Smoke temples, clear lens
CRWDC117	Deuce®, Smoke temples, Silver mirror lens
CRWDC119	Deuce®, Smoke temples, indoor/outdoor Clear mirror lens
CRWDC120	Deuce®, Blue temples, Clear lens
CRWDC129	Deuce®, Blue temples, indoor/outdoor Clear mirror lens
CRWDC13B	Deuce®, Brown temples, Brown lens
CRWDC140	Deuce®, Frost temples, Clear lens
CRWDC149	Deuce®, Frost temples, indoor/outdoor Clear mirror lens

PART #'S AND STYLES LISTED ABOVE ARE FOR REGULAR SIZE

**THE DEUCE STYLES ARE ALSO AVAILABLE
IN SMALL SIZES WITH THE SAME COLOR
TEMPLES AND LENS**

TAHOE®

This stylish frame features 52mm round lenses and the tortoiseshell look of designer frames. The adjustable nosepiece features a one-piece PVC nose pad. The frame is manufactured using a nickel-silver construction for strength and durability. The Tahoe frame may also be fitted with prescription lenses with the clip-on serving as extra protection. Optional wire-mesh and plastic cup sideshields provide maximum protection.



Part #	Description
CRW77010	Tahoe®, Clear lens, no sideshields
CRW77112	Tahoe®, Grey lens, wire-mesh sideshields
CRW77110	Tahoe®, Clear lens, wire-mesh sideshields
CRW77210	Tahoe®, Clear lens, polycarbonate sideshields

IMPRINTABLES

POWERPLUS CAN IMPRINT ON A VARIETY OF STYLES!

**CALL TODAY FOR A QUOTE ON
YOUR CUSTOM PRINT JOB!!!**



Eye and Face Protection

SNAKESKINS® EYEGGLASS CORDS



Part #	Description
CRW215	SNAKESKINS®, Black
CRW216	SNAKESKINS®, Blue
CRW217	SNAKESKINS®, Red
CRW218	SNAKESKINS®, Purple

LENS CLEANING STATION

Contains two boxes of 300 interfolded tissues and one 8-oz. bottle of Anti-Fog, Anti-Static cleaning spray



Part #	Description
CRWLCS1	Lens Cleaning Station

SPEC SAVERS

ANTI-STATIC, ANTI-FOG cleaning towelettes (100/Box, 10 boxes/cs)



Part #	Description
CRWLCT	Spec Savers, 100/bx.

VERDICT® GOGGLE

Crews premium VERDICT® goggle, as well as all their protective goggles, can be worn with most half-mask respirators and fits over most prescription frames. The VERDICT® is available with an optional foam lining and with either an elastic headband or a neoprene headband. As part of the RX Option® System, the Verdict is also available with prescription lens inserts.

VERDICT GOGGLE #CRW2400



VERDICT GOGGLE #CRW2400F



ECONOMY GOGGLE (REGULAR SIZE) #CRW2220



CHEMICAL SPLASH GOGGLE #CRW2230R



Eye and Face Protection



BANDIT™

The **uvex BANDIT™** has a contemporary, sporty wrap around styling along with easy and economical patented lens replacement system. The adjustable temple length ensures comfortable and custom fit. Frame colors of black, earth and slate blue go well with lens tints clear, amber, expresso, mirror, SCT-reflect50 and SCT-gray. Made in the USA. Meets ANSI Z87.1-1989

PART #	STYLE	FRAME COLOR	LENS TINT & COATING
S1600	Bandit	Black	Clear/UD
S1603	Bandit	Black	ESP/UD
S1604	Bandit	Black	Mir/UD
S1606	Bandit	Black	SCT-reflect 50 UD
S1614	Bandit	Copper	Mir/UD



SKYPER®

The **uvex SKYPER®** protective eyewear commands protection with both style and comfort. A sporty wrap-around protective spectacle, offering its wearers exceptional protection, comfort and fit. Its unique lens design incorporates the simplicity of a unilens, with a sleek, stylish appeal. A molded-in nosebridge, sideshields and browguard provide exceptional coverage. **uvex skyper** also has a simple lens replacement system. Patented, adjustable **uvex duoflex®** temples and adjustable lens inclination allow **uvex SKYPER®** to provide a customized fit. The lens features exclusive **uvextreme®AF** anti-fog coating or **uvex ultradura®hardcoat (UD)**. **uvex SKYPER®** . . . exceptional protection, superior comfort and sleek design . . . Protection With Intrigue. Made in the USA. Meets ANSI Z87.1-1989 and CSA Z94.3-1992 High impact protector.

PART #	STYLE	FRAME COLOR	LENS TINT & COATING
S1900	Skyper	Black	Clear/UD
S1920	Skyper	Gunmetal	Clear/UD

ASTROSPEC 3000®

These spectacles have a single panoramic, 100% polycarbonate, impact-resistant lens. They are fully adjustable with a patented lens inclination, adjustable temple length, and a universal nosebridge. They are extremely lightweight and offer a unique, easy, and economical lens replacement system. The nylon frame is available in a variety of colors: blue, black, gold, silver, hot red, yellow/black, and patriot. Lenses are available in clear, gray, amber, mirror, SCT gray, SCT blue, SCT low IR, SCT vermilion, and Infradura® welding shades 3.0 and 5.0 with your choice of **Uvextreme® AF**, the anti-fog coating or **Ultradura®** hardcoat lens coatings. The lens absorbs > 99.9% of harmful UV light. They meet industry standards ANSI Z87.1-1989 and CSA Z94.3-1992. Custom imprints available. Made in the USA.



PART #	STYLE	FRAME COLOR	LENS TINT & COATING
S1169	Astrospec 3000	Patriot RWB	Clear/UD
S1179	Astrospec 3000	Patriot RWB	Gray/UD
S129C	Astrospec 3000	Blue	Clear/XTR
S135	Astrospec 3000	Black	Clear/UD
S1359	Astrospec 3000	Black	Clear/UD
S135C	Astrospec 3000	Black	Clear/XTR
S136	Astrospec 3000	Black	Clear/UD

ASTROSPEC 3000® S (SLIM)

These spectacles have the same features and benefits as the Astrospec 3000. In addition these are 10 mm smaller for employees with slender facial profiles. Made in the USA.



PART #	STYLE	FRAME COLOR	LENS TINT & COATING
S2700	Astrospec 3000 Slim	Black	Clear/UD

ASTRO OTG® 3001

These spectacles have the same features and benefits as the Astrospec 3000 with an attractive OTG over-the-glass styling. These are an economical alternative to expensive Rx eyewear. Made in the USA.



PART #	STYLE	FRAME COLOR	LENS TINT & COATING
S2500	Astro OTG 3001	Black	Clear/UD
S2530	Astro OTG 3001	Patriot RWB	Clear/UD

Eye and Face Protection

uvex



U2™

uvex U2™ protective eyewear delivers exceptional coverage with both style and comfort. This sporty wrap-around protective spectacle offers its wearers protection, comfort and fit. Its unique lens design incorporates the simplicity of a uni-lens, with a sleek, contemporary look and economy of an easily replaceable lens. The patented wrap-around lens design provides exceptional coverage and excellent field of vision. **uvex U2™** also has a simple lens replacement system. Adjustable spatulite temples secure and allow **uvex U2™** to provide a customized fit. Made in the USA. Meets ANSI Z87.1-1989 and CSA Z94.3-1992 Standards.

PART #	STYLE	FRAME COLOR	LENS TINT & COATING
S3100	U2	Black	Clear/UD
S3103	U2	Black	Mirror/UD
S3110	U2	Earth Brown	Clear/UD
S3111	U2	Earth Brown	ESP/UD



TOMCAT™

The **uvex Tomcat™**, has impact-resistant polycarbonate lenses that absorb greater than 99% of harmful UVA and UVB rays. The optically corrected 10-base lens design creates the popular “wrap” styling for eye socket protection and ensures optimal visual performance without compromising the optical quality of the lens. For all-day comfort and a great fit, the **uvex Tomcat™** has adjustable saddle nose pads and soft, flexible temple grips. Available in an eye-catching “gunmetal” frame, the **uvex Tomcat™** is lightweight and durable with a protective hardcoat to minimize scratching, and are available in an assortment of tints. Meets ANSI Z87.1-1989 Standard.

PART #	STYLE	FRAME COLOR	LENS TINT & COATING
S2453	Tomcat	Gun Metal	Mirror/Hardcoat

ASK AN

Powerplus TEAM MEMBER

ABOUT REPLACEMENT LENS (AVAILABLE FOR MOST STYLES)

FURY®



The perfect combination of a spectacle and a goggle. “Provides exceptional protection from dirt, dust and flying particles.” Face foam and headband are flame retardant. Made in the USA. Meets ANSI Z87.1-1989 and CSA Z94.3 High impact protector.

STEALTH™



“A REVOLUTION IN COMFORT, FIT AND PROTECTION!”

Impact/dust/mist/splash protector. Quick and economical lens replacement. Specially designed Rx Carrier for workers requiring prescription glasses. Made in the USA. ANSI Z87.1-1989 and CSA Z94.3-1992 High impact protector

PART #	STYLE	FRAME COLOR	LENS TINT & COATING
S3960C	Stealth Goggle	Gray/Gray	Clear/XTR
S1890	Fury goggle	Black	Clear/XTR



Eye and Face Protection

AMERICAN ALLSAFE 'CUDAS™



These slim profile 'Cudas™ offer the 'Cudaslide™ adjustable temple for individual fit with five different lengths. Six-base lens curve and folded-back lens design provide increased peripheral vision and protection. The stylish frames are made of durable, modified nylon. New 'Cudas™ tinted lenses include: Amber, which "illuminates" low-light indoor conditions (ideal for numerous QC inspections) and Vermilion, which blocks "glare" or "blue light" and improves color contrast (ideal for examination of metals and/or glass products). Pad printing is available.

Part #	Description
19142	Black Frame, Clear Lens
19143	Black Frame, Clear Lens, FogGard
19144	Black Frame, Smoke Lens
19145	Black Frame, Smoke Lens, FogGard
19146	Black Frame, Sunburst Mirror Lens
19147	Black Frame, Blue Steel Mirror Lens
19148	Black Frame, Vermilion Lens
19149	Black Frame, Amber Lens
19157	Blue Frame, Clear Lens
19158	Blue Frame, Clear Lens, FogGard
19159	Blue Frame, Smoke Lens

AMERICAN ALLSAFE COMPANY®

MONOGOGGLE® 211

These indirect ventilation goggles have a separate nosepiece made from soft, pliable plastic for snug, comfortable seal. The polycarbonate lens is .060" thick. The frame is designed with a pantascopic angle to improve work area visibility. Patented ventilation increases airflow, while protecting against chemical splash.



Part #	Description
G-211-13R	Goggles, Indirect Vents, Clear Lenses, FogGard
G-211-99R	Goggles, Indirect Vents, Clear Lenses, FogGard, Respiratory Fit

MRX^V™

These indirect ventilation goggles have a spherical lens that provides a vision range of more than 160° while protecting against chemical splash. The polycarbonate lens is .090" thick. A felt option is also available.



Part #	Description
10277	Goggle, Blue Frame, Clear Lenses, FogGard
10281	Goggle, Smoke Frame, Clear Lenses, FogGard

'CUDAS™ CADDY

The 'Cudas™ Caddy stores one pair of 'Cudas™ spectacles and two replacement lenses for a variety of applications/situations. It features belt loops for convenience. Custom screening is available.



Part #	Description
19175	Caddy, Black Frame/Clear Lenses, Amber and Smoke Lenses
19179	Caddy, Black Frame/Clear Lenses, Smoke and Purple Mirror Lenses
19174	Caddy Only

AMERICAN ALLSAFE AXIA™

This stylish Spectacle is popular with workers so it encourages compliance. It features a six-base curved lens that gives you 170° of peripheral vision. And there's no frame to obstruct your view. It's simply a lens and temples, that's all. The AXIA™ temple pivots 21° with a 4pt adjustable temple length.



Part #	Description
19301	Jet Black Frame, Clear FogGard® Plus lens
19312	Indigo Blue Frame, Clear FogGard® Plus lens
19303	Jet Black Frame, Smoke FogGard® Plus lens
19314	Indigo Blue Frame, Smoke FogGard® Plus lens

AMERICAN ALLSAFE 'CUDASEVEN

Seven-base curved lens for wrap around protection and no distortion in peripheral vision. CudaSeven has adjustable temples



Part #	Description
19421	Grey Frame, Clear FogGard® Plus lens
19422	Grey Frame, Smoke FogGard® Plus lens
19365	Grey Frame, Blue mirror lens
19366	Emerald Frame, Gold Mirror lens

MONOSHIELD™ w/GOGGLE

The MonoShield is made from optical-grade polycarbonate material. It provides splash and impact protection. The PVC gasket snugs against goggle to mate the MonoShield™ and MonoGoggle®. Supplied with the FogGard® Plus MonoGoggle 211. Use only with MonoGoggle® 211 goggles.



Part #	Description
10179	Monoshield with Goggles, Clear Lenses

NOTE: All American Allsafe goggle lenses are made from optical-grade polycarbonate and provide 99.9% UV protection. Replacement lenses are available, specify name of goggle when ordering.

Eye and Face Protection

ALUMINUM RIM HEADGEAR BRACKET (shown with faceshield*)

CRW102



RATCHET TAKE-UP HEADGEAR (shown with faceshield*)

CRW103



Part #	Description
CRW102	Aluminum Rim, Headgear Bracket
CRW103	Ratchet Take-up Headgear
CRW181540	Faceshields, Polycarbonate Material
CRW181640	Faceshields, PETG Material

AYE MATE® UNIVERSAL SIDESHIELDS are quickly adaptable to a wide range of metal and plastic frames. Can be installed or removed easily without tools. Eliminates guess work, time and effort required to replace lost or broken OEM sideshields. Molded from impact-resistant polycarbonate. Exclusive UVS additive provides an ultraviolet barrier which effectively attenuates UV rays up to 380 nanometers. Patented. Meets ANSI Z87 specifications. Sold Individually.



Part #	Description
B-52	AYE MATE® UNIVERSAL SIDESHIELDS, Clear
B-53	SUN MATE® UNIVERSAL SIDESHIELDS, Grey



THERMOPLASTIC WELDING HELMETS

TIGERHOOD® helmets are the lightest weight standard size welding helmets made by Fibre-Metal. They are molded from *Noryl**, a tough weight-to-strength, heat resistant thermoplastic. Their universal shell shape combines under-chin and straight-front helmet benefits to increase welder comfort and protection. Choice of patented, telescoping liftfront, stationary, molded-in, or wide vision molded-in glassholder models. Molded-in, scratchproof colors, silver coating available at no additional cost.

*Noryl is a General Electric Co. register trademark.

Part#	Description
906	Thermoplastic welding helmet, w/flip view window
910	Thermoplastic welding helmet
990	Thermoplastic welding helmet, wide view
5906	Thermoplastic welding helmet, w/flip view window, Speedy-Loop System
5910	Thermoplastic welding helmet, Speedy-Loop System
5990	Thermoplastic welding helmet, wide view Speedy-Loop System
FM-66	Deep shearling wool sweatband, washable, easy snap on/off

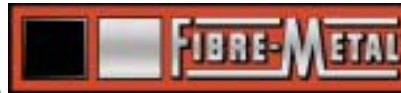

WINDOWS/SCREENS HIGH PERFORMANCE® WINDOWS

High Performance windows are injection-molded propionate, job-proven superior to cut-acetate in every significant performance characteristic. Crystal clear and green tint available in standard-wide- and extended-view sizes. Pre-shaped at the factory for ease of attachment to crown protectors. Top quality IR/UV windows provide shape 5 projection against flash encountered in oxy-acetylene welding, cutting and brazing operations.



#4178 #4199

Part #	Description
4118	Standard view
4178	Wide view
4178IR/UV	Wide view scale, shade 5 w/UR/UV
S-178	Wide view screen
4199	Extended view
4199-IR/UV	Extended view scale, shade 5 w/UR/UV
S-199	Extended view screen

SPEEDY-LOOP SYSTEM

Fibre-Metal's redesigned model 5000 SPEEDY Loop is the first adjustable mounting loop to provide a better fit on each style Fibre-Metal protective cap along with most major competitive brands. The new 5000 SPEEDY Loop is also 20% lighter, includes a more secure brim tab design and contains no metal part so caps can maintain their ANSI Class E rating.



Part #	Description
5000	Speedy-Loop System

Head Protection

V-GARD® PROTECTIVE CAPS AND HATS



V-Gard Protective Caps and Hats from MSA consist of a polyethylene shell and suspension system working together as a protection system. V-Gard headwear features advanced styling in either cap or hat styles, with the caps available in three sizes: small (6-7¹/₈), standard (6¹/₂-8) and large (7¹/₂-8³/₄). V-Gard Caps and Hats meet or exceed the applicable requirements for a Type I helmet (top impact) as outlined in ANSI Z89.1 1997, Class E and G (formerly Class B and A). V-Gard Caps and Hats are not specifically designed to protect against lateral blows from the front, side or rear. MSA's lateral protective helmets are so designed and must be used if lateral protection is desired.

Part #	Description
CAPS	
463942	Standard, Slotted Cap, Staz-On Suspension, White
475358	Standard, Slotted Cap, Fas-Trac Suspension, White
463943	Standard, Slotted Cap, Staz-On Suspension, Blue
475359	Standard, Slotted Cap, Fas-Trac Suspension, Blue
463944	Standard, Slotted Cap, Staz-On Suspension, Yellow
475360	Standard, Slotted Cap, Fas-Trac Suspension, Yellow
463945	Standard, Slotted Cap, Staz-On Suspension, Orange
475361	Standard, Slotted Cap, Fas-Trac Suspension, Orange
463947	Standard, Slotted Cap, Staz-On Suspension, Red
475363	Standard, Slotted Cap, Fas-Trac Suspension, Red
463946	Standard, Slotted Cap, Staz-On Suspension, Green
475362	Standard, Slotted Cap, Fas-Trac Suspension, Green
463948	Standard, Slotted Cap, Staz-On Suspension, Gray
475364	Standard, Slotted Cap, Fas-Trac Suspension, Gray

Part #	Description
HATS	
454733	Non-Slotted Cap, Staz-On Suspension, White
475369	Non-Slotted Cap, Fas-Trac Suspension, White
454732	Non-Slotted Cap, Staz-On Suspension, Blue
475368	Non-Slotted Cap, Fas-Trac Suspension, Blue
454730	Non-Slotted Cap, Staz-On Suspension, Yellow
475366	Non-Slotted Cap, Fas-Trac Suspension, Yellow
454734	Non-Slotted Cap, Staz-On Suspension, Orange
454736	Non-Slotted Cap, Staz-On Suspension, Red
475371	Non-Slotted Cap, Fas-Trac Suspension, Red
454735	Non-Slotted Cap, Staz-On Suspension, Green
475370	Non-Slotted Cap, Fas-Trac Suspension, Green
454731	Non-Slotted Cap, Staz-On Suspension, Gray
475367	Non-Slotted Cap, Fas-Trac Suspension, Gray

Replacement Suspension

454230	Replacement Suspension, Staz-On
473332	Replacement Suspension, Fas-Trac

SKULLGARD® PROTECTIVE CAPS AND HATS

Skullgard Caps and Hats feature heavy-duty construction for use as head protection in steel mills and other heavy industries where elevated temperatures are common.

Skullgard Caps and Hats meet or exceed the applicable requirements for a Type 1 helmet (top impact) as outlined in ANSI Z89.1 1994, Class G (electrical-low voltage) (formerly Class A). **WARNING!** Do not mix suspension and helmet sizes. Make sure the sizes match (example: standard-size suspension with standard-size helmet). Use only MSA suspensions on an MSA helmet. **Failure to comply with the above will reduce the energy-absorbing ability of the protective helmet, which can result in serious injury or death.**

Part #	Description
475395	Skullgard Cap w/Fas-Trac Suspension, Natural Tan
475407	Skullgard Hat w/Fas-Trac Suspension, Natural Tan





CHINSTRAPS

MSA Chinstraps can be worn to help keep protective caps and hats stable on the worker's head during strenuous activity or windy conditions.

Part #	Description
88128	Elastic, Plastic Hooks & Buckles (attaches to the shell)
81391	Elastic, Plastic Fasteners (attaches to the suspension)



GOGGLE RETAINERS

MSA Goggle Retainers hold goggles securely on cap or hat, making goggles conveniently available for immediate use.

Part #	Description
459458	Goggle Retainer for Protective Caps (less goggles)
449895	Goggle Retainer for Protective Hats (less goggles)



CUSTOM TERRI-BAND SWEATBAND

Fits all MSA helmets. Provides excellent absorption, is easily washable and has no metal parts. Offers great fit and comfort.

Part #	Description
696688	Custom Terri-Band Sweatband, 10/PK



IF A CUSTOM LOGO HARD HAT IS WHAT YOUR COMPANY REQUIRES JUST ASK ONE OF OUR EXPERIENCED TEAM MEMBERS

FOR MORE INFORMATION AND LET US CUSTOMIZE YOUR NEXT HEAD PROTECTION ORDER!

AMERICAN ALLSAFE COMPANY® THERMAL - WINTERWARE

305 TSL

- Thinsulate innerpanels and red heavyweight fleece lining
- Full head and neck coverage with extra-wide wrapped collar
- Shoulder-length liner can be tucked into jacket
- 100% cotton, 7 - 8oz. blue twill exterior with black fastener
- Thinsulate is a registered trademark of 3M
- Temperature range: 0° to -20°F *or* -20° to -40°C



#22383

225Plus

- Blue quilted nylonshell with fastener straps
- Three layers of thick foam
- Meets 16 CFR 1610, Class 1
- Temperature range: 45° to 32°F *or* 8° to 0°C



#22298

Head Protection

SUPEREIGHT MODEL E-1 FULL BRIM PROTECTIVE HAT



Technically advanced head protection with an extra margin of protection from the sun, non-toxic splash, dust, dirt and debris. Protect outdoor workers from the sun's harmful ultraviolet ray's with Fibre-Metal's model E-1 SUPEREIGHT, full brim protective hats. Fibre-Metal's full brim hats shade more of the face, neck, and ears while providing the degree of protection and comfort that makes our SUPEREIGHT hats the quality leader in head protection. Model E-1 has exclusive features and benefits that wearers appreciate and safety officials value. The closer you look the more you will see its advantages. SEI certified to comply with ANSI-Z89.1 Type 1, Class E standards E-1; are available in white, yellow, green, red, and blue in a choice of three distinctive headbands to ensure fit and feel for every wear's personal preference. The E-1 can be imprinted in the same manner as protective caps for an additional charge.

Part #	Description
E-1RW-WE	Non-Slotted, Ratchet Suspension, White
E-1RW-YE	Non-Slotted, Ratchet Suspension, Yellow
E-1RW-GN	Non-Slotted, Ratchet Suspension, Green
FM-SS1-WE	Sunshield, Lightweight cotton, 17"x12", White
FM-SS2-OR	Sunshield, Lightweight cotton, 12"x14", Orange
FM-44R	Vinyl wrapped foam sweatband, easy wraparound



SUPEREIGHT MODEL E-2W PROTECTIVE CAP

Model E-2's design allows for protection while maintaining comfort and aesthetics. The smooth crown design distinguishes it from competitive models with reinforcing ribs, ridges and slots in the shell. SUPEREIGHT model E-2 series caps are equipped with a technically advanced, eight-point impact energy control system that reduces impact energy. A 360 degree sweatband is padded for comfort and perforated to allow air to circulate. Can be tilted to a comfortable wearing angle while the cap remains level for maximum protection. The 3-R Action-Gear® headband has a convenient, large ratchet sizing mechanism that can be adjusted with a gloved hand while the cap is on the head. The headband anchors protective caps comfortably, during extreme activity, high winds, or with accessories mounted on the cap. Available in a wide variety of colors. All SUPEREIGHT components are produced and assembled under strict SEI certified quality control.

Part #	Description
E-2W-WE	Non-Slotted, Standard Suspension, White
E-2RW-WE	Non-Slotted, Ratchet Suspension, White
E-2RW-YE	Non-Slotted, Ratchet Suspension, Yellow
E-2RW-RD	Non-Slotted, Ratchet Suspension, Red
E-2RW-BE	Non-Slotted, Ratchet Suspension, Blue
E-2RW-OE	Non-Slotted, Ratchet Suspension, Orange
E-2RW-GN	Non-Slotted, Ratchet Suspension, Green
E-2RW-GY	Non-Slotted, Ratchet Suspension, Gray
S-2F	Leatherette head band
3-RW2	Replacement Suspension, Ratchet



Hearing Protection



MAX[®] DISPOSABLE

Max[®] (NRR 33) pre-shaped foam earplugs feature a smooth outer skin for maximum user comfort. The NRR 33 rating makes MAX[®] the highest rated earplug in the U.S. The smooth, soil-resistant skin helps prevent foreign material from penetrating the surface while rolling prior to insertion. Attenuation tested in accordance with ANSI S3.19-1974. Noise reduction rating NRR 33 dB, SNR 34 dB. Orange.



Part #	Description	Quantity
MAX-1	Max, without cord, self-dispensing boxes	200 pr/bx
MAX-30	Max, with cord, self-dispensing boxes	100 pr/bx

MAXLITE[®] DISPOSABLE

MAX-LITE[®] (NRR 30) low pressure foam earplugs offer long term user comfort not found in other pre-shaped foam earplugs. The non-irritating, non-allergenic self-adjusting foam recovers to fit virtually any ear canal. MAX-LITE[®] is ideal for that portion of the population with smaller ear canals. Attenuation tested in accordance with ANSI S3.19-1974. Noise reduction rating NRR 30 dB, SNR 34 dB. Green.



Part #	Description	Quantity
LPF-1	Max-lite, without cord, self-dispensing boxes	200 pr/bx
LPF-30	Max-lite, with cord, self-dispensing boxes	100 pr/bx

LASER LITE[®] DISPOSABLE

LASER-LITE[®] (NRR 32) is the multi-color earplug that workers love to use. The non-irritating, non-allergenic self-adjusting foam recovers to fit virtually any ear canal. LASER-LITE[®] is ideal for that portion of the population with smaller ear canals. Attenuation tested in accordance with ANSI S3.19-1974. Noise reduction rating NRR 32 dB, SNR 35 dB. Magenta/Yellow.



Part #	Description	Quantity
LL-1	Laser Lite, without cord, self-dispensing boxes	200 pr/bx
LL-30	Laser Lite, with cord, self-dispensing boxes	100 pr/bx

QUIET[®] REUSABLE

QUIET[®] is a reusable foam earplug that requires no rolling prior to insertion. Insert using the built-in flexible orange stem. Washes with soap and water for weeks, or even months of protection. Attenuation tested in accordance with ANSI S.3.19-1974. Noise reduction rating NRR 26 dB, SNR 28 dB. Orange color.



Part #	Description	Quantity
QD-30	Quiet, with cord, self-dispensing boxes	100 pr/bx
QD1-PK	Quiet, without cord, self-dispensing boxes	100 pr/bx

LASER-TRAK[®]

The only disposable detectable earplug on the market today! All the economy, safety, comfort, attenuation ... and it's detectable, too. All these great features come together in the new LASER-TRAK[®] (NRR 32)! The only earplug that is both disposable and detectable. Comfortable styling that also provides high attenuation in tandem with detectability. Made of bright and intensely visible orange and blue coloring for extra visibility in food processing environments. Nonferrous metal is highly detectable by metal detection devices. Corded for extra safety and convenience.



Part #	Description	Quantity
LT-30	Laser-trak, with cord, self-dispensing boxes	100 pr/bx

D-TEK[®] DETECTABLE

Long-wearing comfort, reusable high level of safety... and detectable. The D-TEK[®] is a great answer for food processing, paper/pulp processing or other environments where detection of foreign objects is a necessity. The metal component is highly detectable, yet inconspicuous to the wearer. Reusable, with simple maintenance of mild soap and water. Attenuation tested in accordance with ANSI S.3.19-1974. Noise reduction rating NRR 24 dB, SNR 25 dB. Bright Orange.



Part #	Description	Quantity
DT-30	D-Tek, Detectable, self-dispensing boxes with cord,	50 pr/bx

Hearing Protection

AIRSOFT™ REUSABLE

Airsoft features a shell of soft attenuating material around a pocket of air that is comfortable enough for extended wear. The highest rated reusable earplug available. Washes with soap and water for months of protection. Attenuation tested in accordance with ANSI S3.19-1974. Noise reduction rating NRR 27 dB, SNR 30 dB. Blue color.



Part #	Description	Quantity
AS-1	Airsoft, without cord, self-dispensing boxes	50 pr/bx
DPAS-1	Airsoft, without cord, self-dispensing boxes	100 pr/bx
AS-30R	Airsoft, with cord, self-dispensing boxes	50 pr/bx
DPAS-30R	Airsoft, with cord, self-dispensing boxes	100 pr/bx

LM-77 FOLDING MUFFS



Never before has such a high attenuating earmuff been available in such a small package! LM-77 is super compact for easy storage when not in use. Noise reduction rating NRR 28 dB, SNR 32 dB. Available in Cobalt Blue (LM-77-BU) or Rocket Red (LM-77-RD).

Part #	Description
LM-77	Leight Muff, folding style



THUNDER 29®

Thunder 29® (NRR 29) is fully dielectric with extra long, padded headband for a comfortable fit. Oversized vinyl cushions help distribute pressure evenly around the outer ear for maximum user comfort. Replaceable and washable soft foam ear cushions are ideal for extended use.



Part #	Description
QM29	Thunder 29, high attenuating dielectric

QM24 +

QM24 + (NRR 24) is a three-position, ultra-lightweight earmuff. Weighs only 6 oz. for comfort during prolonged usage. The high visibility red cups and black band add style to an extremely functional earmuff. Supplied with adjustable crown strap for a secure fit when worn behind the head or under the chin. Low cost cushions are easily removed for replacement.



Part #	Description
QM24 +	QM24 +, dielectric, crown strap

THE NEWEST LEGACY FROM HOWARD LEIGHT...THE NEXT GENERATION OF QUIET BANDS.

This time with a twist. The new ergonomic design of the band keeps the pads suspended so they don't become contaminated when you set the Quiet Bands down. To name this unique design, the word we choose to best describe this feature is the direct benefit to you... HYGIENE. The symbol for the new Quiet Band family is HYG.



The **QB1HYG**® has an NRR of 27, the highest attenuation among banded hearing protectors. The QB1HYG is a unique blend of our Quiet® earplug, attached with a soft flexible stem to the new Quiet Band. The result is a highly comfortable, effective noise attenuating protection product for inner-aural use.



The **QB2HYG**® (NRR 25) has softly styled foam pads shaped for supra-aural protection. The pads fit easily inside the ear canal opening and provides a level of protection at NRR 25.



The **QB3HYG**® (NRR23) is designed for those who require moderate or intermittent hearing protection, as the semi-aural pads fit just to the ear canal opening. With a soft comfortable fit, the QB3HYG, is a great choice with an NRR of 23.

REPLACEMENT PADS FOR ALL BANDS ARE AVAILABLE!

Part #	Description
QB1HYG	QB1 Band, banded inner-aural hearing protector with 1 free pair QB100 ^{HYG} ® replacement pads enclosed
QB2HYG	QB2 Band, banded supra-aural hearing protector with 1 free pair QB200 ^{HYG} ® replacement pads enclosed
QB3HYG	QB3 Band, banded semi-aural hearing protector with 1 free pair QB300 ^{HYG} ® replacement pads enclosed

Hearing Protection

PURA-BAND®



Canal Cap Hearing Protector

The lightweight Pura-Band can be comfortably worn under the chin or behind the head. Durable, soft caps seal off the ear canal for a NRR 20 protection level. The caps are washable and are non-toxic and non-allergenic. 10/BX



Part #	Description	Quantity
6502	Pura-Band, Reusable, Banded	ea.

PURA-FIT®

Soft Foam Ear Plugs

High NRR 31 rating is suitable for most industrial environments. Tapered for easy insertion in any size ear canal. Made from softer foam with a non-irritating, smooth surface for comfort. Longer length for easy fitting and removal. Bright green color for easy compliance checks. NRR 31 rating. Corded model is ideal for food processing and chemical applications.



Part #	Description	Quantity
6800	Pura-Fit, Disposable, without cord	200 pr/bx
6900	Pura-Fit, Disposable, with cord	100 pr/bx

ASK ONE OF OUR
TEAM MEMBERS
ABOUT BULK PRICING

JAZZ BAND®

Semi-Aural Hearing Protection

JAZZ BAND® semi-aural hearing protectors are cool and comfortable to wear. The high NRR25 rating makes it an ideal alternative to muffs. The replaceable foam pods feature Moldex's exclusive AdB® coating to help provide maximum attenuation and to repel dirt. Pods can be washed and reused. Optional breakaway neck cord allows the JAZZ BAND® to conveniently hang around the neck when not in use. Spare pods included in each package. Each replacement package contains 5 pair of JAZZ Pods and one neck cord per bag. 10 bands/bx



Part #	Description	Quantity
6506	Jazz Band, Reusable, Banded	ea.
6504	Jazz Band, Replacement Pods & Neck Cord	10/pk

SPARKPLUGS®

Multi-Color Foam Earplugs

Fun colored SparkPlugs are sure to put some spark in your hearing protection program. Every package reveals random colored SparkPlugs. The soft foam, tapered design fits snugly in the ear for a comfortable fit. High NRR 30 rating provides protection for most industrial environments. Bright, fun colors provide easy compliance checks.



Part #	Description	Quantity
6604	SparkPlugs, without cord	200 pr/bx
6654	SparkPlugs, with cord	100 pr/bx
6606	SparkPlugs Pocket-Pak, without cord	100 paks pr/bx
6656	SparkPlugs Pocket-Pak, with cord	100 paks pr/bx

PLUGSTATION®

Give workers easy access to hearing protection. High visibility dispenser increases awareness for your hearing conservation program. Affordable enough to be placed near every work area. PlugStation eliminates the mess of individual paper/poly bag packaging which reduces the facility maintenance costs. Available in 250 or 500 pair per Plug Station with either SparkPlugs (NRR30) or Pura-Fit (NRR31) earplugs. Includes mounting bracket and hardware.

Part #	Description	Quantity
6644	Plugstation, SparkPlugs, Dispenser	250 pr/ds
6645	Plugstation, SparkPlugs, Dispenser	500 pr/ds
6844	Plugstation, Pura-Fits, Dispenser	250 pr/ds
6845	Plugstation, Pura-Fits, Dispenser	500 pr/ds



Respiratory Protection



Series 7600
(Shown with 7584P100 Cartridges)



42CFR84 APPROVED MEETS OSHA REQUIREMENTS

NORTH 7600 SERIES FULL FACEPIECE, AIR-PURIFYING RESPIRATORS

The North 7600 Series full facepiece respirators are designed to provide eye, face and respiratory protection while providing optimum comfort. While affording an over 200° field of vision, the hard coated polycarbonate lens protects the wearer's eyes and face against irritating gases, vapors and flying particles. The polycarbonate lens also features optical properties to minimize distortion and astigmatism.

Part #	Description	Sizes
7600-8A	Full Face, Air-Purifying, Respirator	S, M/L

NORTH 7700 SERIES HALF MASK, AIR-PURIFYING RESPIRATORS

The North 7700 Series is the most comfortable half mask respirator available today. What makes it so comfortable? For one thing, the facepiece is made of soft, non-allergenic silicone. Because silicone is so much more flexible than organic rubber, it conforms to a worker's face. Three facepiece sizes make it much easier to fit your workers.

The North 7700's cradle suspension system also adds to the comfort of this respirator. The North 7700 doesn't slip like respirators with conventional strap systems. The cradle suspension gives an even seal without creating pressure points.

The low profile of the North 7700 gives workers a wide field of vision and room for protective eyewear. Its low inhalation and exhalation resistance makes breathing easier, leaving more energy for production.

Part #	Description	Sizes
7700-30	Half Face, Air-Purifying, Respirator	S - L

Series 7700
(Shown with N7500-3 Cartridges)



42CFR84 Approved
Meets OSHA Requirements

Series 5400
(Shown with 7581P100 Cartridges)



42CFR84 APPROVED
MEETS REQUIREMENTS OF
ANSI Z87.1-1998



NORTH 5400 SERIES FULL FACEPIECE AIR PURIFYING RESPIRATOR

NIOSH CERTIFIED WHEN USED WITH ALL NORTH CARTRIDGES AND FILTERS

The 5400 Series is compatible with all existing North cartridges, filters and accessories, such as the CF2000 Series Continuous Flow Airline Attachment, the BP1000 Series Backpack Adapter, and the North Full facepiece welding attachment.

A lighter weight full facepiece weighing only 14 ounces, the 5400 Series lightweight design offers a level of comfort that will ensure greater worker acceptance. Plus its facepiece is made from soft pliable material with high chemical resistance to assure excellent fit and performance.

The 5400 series is suitable for any application that requires full facepiece air-purifying protection. Typical applications include welding (with the welding attachment), smelting, paint and hazardous waste removal.

Part #	Description	Sizes
54001	Full Facepiece	S, M/L

Respiratory Protection



A COMPLETE SET OF CARTRIDGES AND FILTERS FOR RESPIRATORY PROTECTION AGAINST A WIDE VARIETY OF INDUSTRIAL AIR CONTAMINANTS

•NIOSH/MSHA certified



N7500-1 ■ **ORGANIC VAPORS CARTRIDGE** - Approved for respiratory protection against organic vapors



N7500-2 □ **ACID GASES CARTRIDGE** - Approved for respiratory protection against chlorine, hydrogen chloride, sulfur dioxide or hydrogen fluoride or formaldehyde



N7500-3 ■ **ORGANIC VAPORS AND ACID GASES CARTRIDGE** - Approved for respiratory protection against organic vapors, chlorine, hydrogen chloride, sulfur dioxide or hydrogen fluoride or chlorine dioxide



N7500-4 ■ **AMMONIA AND METHYLAMINE CARTRIDGE** - Approved for respiratory protection against ammonia and methylamine



7580P100 ■ **P100 PARTICULATES FILTER (HEPA)** - 99.97% efficient against solid or liquid particles including oilbased particles



7581P100 ■ **ORGANIC VAPORS, HIGHLY TOXIC PARTICULATES, AND PAINT LACQUER AND ENAMEL MISTS CARTRIDGE** - Approved for respiratory protection against mists of paints, lacquers and enamels; organic vapors; dusts, fumes and mists having a time-weighted average less than 0.05 milligram per cubic meter; radon daughters attached to these dusts, fumes and mists; asbestos containing dusts and mists; radionuclides; pesticides; not to be used for protection against paints containing isocyanate or for protection against fumigants



7582P100 ■ **ACID GASES AND HIGHLY TOXIC PARTICULATES FILTER/CARTRIDGE** - Approved for respiratory protection against chlorine, hydrogen chloride, sulfur dioxide or hydrogen fluoride or formaldehyde; dusts fumes and mists having a time-weighted average less than 0.05 milligram per cubic meter and asbestos containing dusts and mists, radionuclides and radon daughters attached to these dusts, fumes and mists



7583P100 ■ **ORGANIC VAPORS, ACID GASES AND HIGHLY TOXIC PARTICULATES FILTER/CARTRIDGE** - Approved for respiratory protection against organic vapors, chlorine, hydrogen chloride, sulfur dioxide or hydrogen fluoride or chlorine dioxide; fumes and mists having a time-weighted average less than 0.05 milligram per cubic meter and asbestos containing dusts and mists, radionuclides and radon daughters attached to these dusts, fumes and mists



7584P100 ■ **AMMONIA, METHYLAMINE AND HIGHLY TOXIC PARTICULATES FILTER/CARTRIDGE** - Approved for respiratory protection against ammonia and methylamine, dusts, fumes and mists having a time-weighted average less then 0.05 milligram per cubic meter and asbestos containing dusts and mists, radionuclides and radon daughters attached to these dusts, fumes and mists



75SCP100 ■ **DEFENDER™ MULTI-PURPOSE CARTRIDGE & P100 ANY PARTICULATES FILTER - 99.97% MINIMUM FILTER EFFICIENCY** - Defender Multi-Purpose Cartridges are approved for protection against Organic Vapors, Chlorine, Hydrogen Chloride, Sulfur Dioxide, Hydrogen Sulfide (Escape), Hydrogen Fluoride, Chlorine Dioxide, Ammonia, Methyl Amine and Formaldehyde.



7506N95 ■ **N95 NON-OIL PARTICULATE PREFILTER - 95% MINIMUM FILTER EFFICIENCY** - NOTE: This prefilter can be assembled to any gas/vapor cartridge (including 3000 Series) by using a N7500-27 filter cover.



Respiratory Protection

ULTRA-TWIN® RESPIRATORS



The Ultra-Twin Full-Facepiece Respirator has an intumed lip around the edge for a tight seal against the face. A large chin cup makes it easy to position. Five suspension headstraps and roller buckles hold the facepiece in place while minimizing hair entanglement. The wide polycarbonate lens is coated to resist scratching and chemical attack. The lens is held in place by a two-piece lens ring which is color-coded to indicate the size of the facepiece. Uses the full line of Comfo Cartridges and Filters. (see page 23)



Part #	Description	Size
471298	Facepiece, Ultra Twin, Hycar, Black	Small
471286	Facepiece, Ultra Twin, Hycar, Black	Medium
471310	Facepiece, Ultra Twin, Hycar, Black	Large

ADVANTAGE® 200 RESPIRATORS

The Advantage 200 Respirator is unlike any other half-mask respirator you'll find. Offering unmatched fit and comfort, it's the first respirator to feature MSA's new patented MultiFlex™ System, a soft, pliable combination of rubber and plastic that provides a virtually customized fit. The result is a respirator that feels great on any face because it works to remove the pressure points from the face seal area. At the same time, the MultiFlex System delivers exceptional stability—which means the Advantage 200 Respirator won't collapse during wear. The MultiFlex System also includes the AnthroCurve™ Sealing Surface which equalizes pressure on the face seal area, thereby eliminating unwelcome pressure points. This design also results in an effective sealing surface that instantly conforms to the wearer's unique facial characteristics. In addition, the Advantage 200 cartridges are compatible with 42 CFR 84 NIOSH-approved Advantage 1000 respirators.



ADVANTAGE 200 FACEPIECES

Part #	Description	Size
815448	Facepiece, Advantage 200	Small
815444	Facepiece, Advantage 200	Medium
815452	Facepiece, Advantage 200	Large

Note: See Chart on ADVANTAGE® RESPIRATOR CARTRIDGES PAGE 21

ADVANTAGE® 1000 RESPIRATORS

The Advantage 1000 Full-Face Respirator has a wrap-around flexible lens that offers a comfortable fit with increased vision. It weighs about 40% less than conventional full-face respirators and uses the same cartridges as the Advantage 200 Respirator.

The Advantage 1000 Respirator is a low-maintenance product and requires only routine filter replacement. Approved by NIOSH for use against a variety of respiratory hazards.

ADVANTAGE 1000 FACEPIECES

Part #	Description	Size
805408	Facepiece, Advantage 1000, Speaking Diaphragm, Nosecup, Black	Medium
805420	Facepiece, Advantage 1000, Speaking Diaphragm, Nosecup, Black	Large



Respiratory Protection

ADVANTAGE® RESPIRATOR CARTRIDGES

MSA Cartridge Designation	Part No.	Color Coding	Contaminants										Filter Type & Efficiency***	See Notes Below			
			Organic Vapor	Chlorine	Sulfur Dioxide	Chlorine Dioxide	Hydrogen Chloride	Hydrogen Sulfide	Ammonia	Methylamine	Formaldehyde	Hydrogen Fluoride			Mercury Vapor		
GMA	815355 (2 in pkg.)	Black															2,3
GMA	815362 (2 in pkg.)	Black/Red															2,3,4
GMB	815356 (2 in pkg.)	White															2
GMB	815363 (2 in pkg.)	White/Red															2,4
GMC	815357 (2 in pkg.)	Orange															2,3
GMC	815364 (2 in pkg.)	Orange/Red															2,3,4
GMD	815358 (2 in pkg.)	Green															2,3
GMD	815365 (2 in pkg.)	Green/Red															2,3,4
GME	815359 (2 in pkg.)	Green/Yellow															2,3
GME	815366 (2 in pkg.)	Green/Yellow/Red															2,3,4
GMF	815360 (2 in pkg.)	Yellow/Black Stripes															2,3
GMF	815367 (2 in pkg.)	Yellow/Black Stripes/Red															2,3,4
GMI	815641 (2 in pkg.)	Red/Yellow															2,4
Mersorb	815361 (2 in pkg.)	Green/Yellow															2,4
MERSORB	815368 (2 in pkg.)	Green/Yellow/Red															2,4
LOW PROFILE	815369 (2 in pkg.)	Red															1,4
STAND-ALONE FLEXI-FILTER	818346 (2 pkg.)	Grey															1
PREFILTER & COVER	815394 N95 (10 in pkg.) 816357 N95(50 in pkg.) 815392 Reusable snap-on cover	Grey															1
PREFILTER & COVER	815397 R95 (20 in pkg.) 815401 Reusable snap-on cover	Grey															1

*Escape only. ** Effective against, but not NIOSH approved for Iodine Vapor.



WARNING

Below is a partial list of gaseous materials for which chemical cartridge respirators must not be used for respiratory protection (for routine use) regardless of concentration or time of exposure. Failure to follow this warning can result in serious personal injury or death. This partial list is far from complete and is offered as a guide to many of the contaminants found in industry. Contact MSA for further information on other specific materials.

Acrolein	Dimethyl sulfate	Nickel carbonyl	Phosphine
Aniline	Hydrogen cyanide	Nitric acid	Phosphorus trichloride
Arsine	Hydrogen selenide	Nitro compounds	Stibine
Bromine	Methanol	Nitrogen oxides	Sulfur chloride
Carbon monoxide	Methyl bromide	Nitroglycerin	Urethane or other diisocyanate-containing paints
Diisocyanates	Methyl chloride	Nitromethane	Vinyl chloride
	Methylene chloride	Phosgene	

Call 1-800-MSA-2222 for the latest information on 42 CFR 84 regulations and newly-approved respirators and cartridges.

***Definitions

P100-Particulate Filter (99.97% filter efficiency level) effective against all particulate aerosols.
 N95-Particulate Filter (95% filter efficiency level) effective against particulate aerosols free of oil; time use restrictions may apply.
 R95-Particulate Filter (95% filter efficiency level) effective against all particulate aerosols; time use restrictions may apply.

Notes

- Do not use in atmospheres containing less than 19.5 percent oxygen, in atmospheres containing gases or vapors or in atmospheres immediately dangerous to life and health.
- Do not use in atmospheres containing less than 19.5 percent oxygen, or in atmospheres immediately dangerous to life and health.
- Do not wear for protection against organic vapors with poor warning properties or those which generate high heats of reaction with the sorbent material in the cartridge.
- 99.97 percent efficient against 0.3 micron DOP.



Respiratory Protection

COMFO CLASSIC® RESPIRATORS



The Comfo Classic Respirator is an improved version of the Comfo II Respirator, featuring new SoftFeel™ facepiece material, which increases the comfort factor dramatically. A result of extensive materials research by MSA, SoftFeel material is an exclusive new formulation that improves the pliability and softness of both Hycar rubber and silicone—the two facepiece materials available with Comfo Classic Respirators. Like earlier Comfo respirator models, the Comfo Classic Respirator features a unique face seal design that gives wearers an exceptional fit.



This Comfo Classic Respirator features a textured sealing surface of SoftFeel silicone which ensures a comfortable, secure fit.

COMFO CLASSIC RESPIRATORS

Material	Color	Small	Medium	Large
SoftFeel Hycar	Black	808075	808074	808076
SoftFeel Hycar	Green	808078	808077	808079
SoftFeel Silicone	Black	808072	808071	808073
SoftFeel Silicone	Yellow	808081	808080	808082

COMFO ELITE® RESPIRATORS

The Comfo Elite Respirator provides protection against a variety of respiratory hazards. The Comfo Elite Respirator, available in black silicone, has a unique sealing surface designed to reduce facepiece slippage. The Comfo Elite Respirator comes in small, medium and large sizes. NIOSH certified.



COMFO ELITE RESPIRATORS

(less filters/cartridges)

Part #	Description	Size
490492	Facepiece, Comfo Elite, Silicone, Black	Small
490491	Facepiece, Comfo Elite, Silicone, Black	Medium
490493	Facepiece, Comfo Elite, Silicone, Black	Large

GME AND GME-P100 SUPER CARTRIDGES - COMFO

Like most combination cartridges, the GME-P100 Super Cartridges provide simultaneous protection against gases, vapors and toxic dusts and mists. But unlike ordinary combination cartridges, the GME-P100 Super Cartridge is NIOSH-approved for 16 specific compounds—far more than any other air-purifying respirator on the market. The GME version gives you NIOSH-approved protection from 10 specific gases and vapors. Add a prefilter and cover to the GME and it also protects against paints, pesticides, dusts, mists and fumes. Because one pair of GME or GME-P100 Super Cartridges replaces many conventional cartridges, the selection process becomes simple, as does employee training. The versatility of these cartridges also reduces the possibility of misuse.



PART #	CARTRIDGE	NIOSH-APPROVED FOR:	CAN BE USED WHERE YOU CURRENTLY USE:
464790	GME CARTRIDGE	Organic Vapors, Sulfur Dioxide, Chlorine, Chlorine Dioxide, Hydrogen Chloride, Hydrogen Sulfide (escape only), Hydrogen Fluoride Gases, Ammonia, Methylamine, Formaldehyde	GMA, GMB, \GMC, GMD, GMF
815182	GME-P100	All of the above plus: Asbestos-containing dusts and mists, Radionuclides	All MSA Air-Purifying Cartridges Dusts**, Mists**, Fumes**, except 3 Specialty Cartridges: GMI-P100, Mersorb and Mersorb-P100



Respiratory Protection

COMFO® RESPIRATOR CARTRIDGES

MSA Cartridge Designation	Part No.	Color Coding	Filter Type & Efficiency***															See Notes Below	
			OV	CL	SD	CD	HC	HS*	AM	MA	FM	HF	MV	P100	R95	N95			
GMA	464031	Black															with R95	with N95	2,3
GMA P100	815178	Black																	2,3,4
GMB	464032	White															with R95	with N95	2
GMB P100	815179	White																	2,4
GMC	464046	Orange															with R95	with N95	2,3
GMC P100	815180	Orange																	2,3,4
GMD	464033	Green															with R95	with N95	2,3
GMD P100	815181	Green																	2,3,4
GME	492790	Olive															with R95	with N95	2,3
GME P100	815182	Olive																	2,3,4
GMF	490173	Diagonal Stripes															with R95	with N95	2,3
GMF P100	815183	Diagonal Stripes																	2,3,4
GMI P100**	815184	Pink																	2,4
MERSORB	466204	Olive															with R95	with N95	2,4
MERSORB P100	815185	Pink																	2,4
P100	815175	Pink																	1,4
SPARKFOE P100	815176	Diagonal Stripes																	1,4
LOW PROFILE P100	815177	Pink																	1,4
STAND-ALONE & COVER	816662 N95 (10 in pkg.) 816661 N95 (50 in pkg.) 489353 Reusable snap-on cover	Grey																	1
PREFILTER & COVER	816662 N95 (10 in pkg.) 816661 N95 (50 in pkg.) 489353 Reusable snap-on cover	Grey																	1
PREFILTER & COVER	816287 R95 (20 in pkg.) 489219 R95 Reusable snap-on cover	Grey																	1

*Escape only. **Effective against, but not NIOSH approved for Iodine Vapor.



WARNING

Below is a partial list of gaseous materials for which chemical cartridge respirators must not be used for respiratory protection (for routine use) regardless of concentration or time of exposure. Failure to follow this warning can result in serious personal injury or death. This partial list is far from complete and is offered as a guide to many of the contaminants found in industry. Contact MSA for further information on other specific materials.

Acrolein	Hydrogen cyanide	Nitric acid	Phosphorus
Aniline	Hydrogen selenide	Nitro compounds	trichloride
Arsine	Methanol	Nitrogen oxides	Stibine
Bromine	Methyl bromide	Nitroglycerin	Sulfur chloride
Carbon monoxide	Methyl chloride	Nitromethane	Urethane or other
Diisocyanates	Methylene chloride	Phosgene	diisocyanate-
Dimethyl sulfate	Nickel carbonyl	Phosphine	containing paints
			Vinyl chloride

Call 1-800-MSA-2222 for the latest information on 42 CFR 84 regulations and newly-approved respirators and cartridges.

***Definitions

P100-Particulate Filter (99.97% filter efficiency level) effective against all particulate aerosols.

N95-Particulate Filter (95% filter efficiency level) effective against particulate aerosols free of oil; time use restrictions may apply.

R95-Particulate Filter (95% filter efficiency level) effective against all particulate aerosols; time use restrictions may apply.

Notes

- Do not use in atmospheres containing less than 19.5 percent oxygen, in atmospheres containing gases or vapors or in atmospheres immediately dangerous to life and health.
- Do not use in atmospheres containing less than 19.5 percent oxygen, or in atmospheres immediately dangerous to life and health.
- Do not wear for protection against organic vapors with poor warning properties or those which generate high heats of reaction with the sorbent material in the cartridge.
- 99.97 percent efficient against 0.3 micron DOP.

Respiratory Protection



OPTIMAIR® MM 2K PAPR WITH TYPE HE OPTIFILTER® XL CARTRIDGE

MSA's new OptimAir MM 2K PAPR with Type HE OptiFilter®; XL Cartridge is smaller, lighter, and less expensive, thanks largely to a new NiMH battery pack and dual-rate smart charger.

The low-profile NiMH (nickel metal hydride) battery pack is lightweight (12.5 oz.), fits close to the body, and is small enough to fit in most pockets. The battery provides 8 hours of continuous use, lasting a full work shift. Another benefit is that NiMH batteries do not have a "memory effect" like NiCd batteries. The sealed, water-resistant battery pack is designed for easy shower decontamination.

The dual-rate smart charger is a standard accessory with this unit. The charger can recharge a battery in less than three hours. An LED indicates battery condition: fast charge, fully charged, or battery fault.

The lightweight, compact design of the OptimAir MM 2K PAPR is well suited for abatement, nuclear, and other industries with hazardous particulate environments. The water-resistant filter has an optional pre-filter and cover.

Complete units include motor/blower, NiMH battery, dual-rate charger, one Type HE OptiFilter XL Cartridge, urethane-coated nylon web belt, and choice of Ultravue or Ultra Elite Facepiece.

The "2K PAPR" is a direct replacement for the OptimAir MM PAPR. We will continue to offer replacement parts for the OptimAir MM PAPR until future notice.

Principle(s) of Operation: The unit filters particulates and provides respirable air directly to the Ultravue® or Ultra Elite® Facepiece. Because it does not have a breathing tube, the unit is more compact than other PAPRs, enhancing user maneuverability and simplifying decontamination.

Approvals and Standards NIOSH Approval TC-21C-0758



OPTIFILTER XL/OPTIFILTER® CARTRIDGES

Part #	Description	Size
10023859	PAPR, OptimAir MM2k, Ultravue Facepiece, Black Silicone	M

REPLACEMENT PARTS

Part #	Description
10023481	Battery Pack for OptimAir MM2K
10023483	Dual-Rate Battery Charger

AFFINITY® LINE OF MAINTENANCE-FREE RESPIRATORS

AFFINITY® PLUS RESPIRATORS

- 95% efficient protection against particulates and non-oil-based aerosols.
- Meets new NIOSH standard 42 CFR Part 84.
- Patented AnthroCurve™ seal.
- Pre-shaped metal nose band for easy adjustment around that "hard-to-fit" nose area.
- Two sizes—small/medium and medium/large, both available with or without exhalation valve.



Part #	Description
816521	Respirator, Disposable, Affinity Plus, N95, Narrow Strap, Medium/Large, 20/PK, 12PK/CS
816525	Respirator, Disposable, Affinity Plus, N95, Narrow Strap, Exhale Valve, Medium/Large, 10/PK, 12PK/CS

AFFINITY® PRO RESPIRATORS

- 95% efficient protection against particulates and non-oil-based aerosols.
- Meets new NIOSH standard 42 CFR Part 84.
- Patented AnthroCurve™ seal, plus foam inner liner for consistent seal and greater comfort.
- Customize with narrow fixed straps for quick, easy donning or with wide adjustable straps so you can make adjustments for individual comfort.
- Optional exhalation valve reduces exhalation resistance while removing hot exhaled breath, making the respirator cooler and more comfortable to wear.
- Opt for either organic vapor or acid gas and hydrogen fluoride nuisance level odor removal.



Part #	Description
816575	Respirator, Disposable, Affinity Pro, N95, Wide Strap, Exhale Valve, Medium, 5/PK, 12PK/CS
816576	Respirator, Disposable, Affinity Pro, N95, Wide Strap, Exhale Valve, Large, 5/PK, 12PK/CS



Respiratory Protection

3M™ 8210 N95



Particulate respirator has been certified by NIOSH as being at least 95% efficient at removing solid and liquid particles (excluding those containing oil). The 8210 is designed to provide quality, reliable worker protection in applications such as grinding, sanding, sawing, sweeping and bagging.

Part #	Description
3M8210	N95, 20/BX

3M™ 8212 N95



Particulate respirator designed for use when welding, torch cutting, soldering, brazing and working with molten metals. Helps provide protection when welding on galvanized and stainless steel. Fits easily under a welding hood. The respirator filter is NIOSH certified to provide at least 95% filter efficiency at removing solid and liquid particles (excluding those containing oil). Adjustable straps, face seal, and 3M™ Cool Flow™ Exhalation Valve provide added comfort and durability. Cake resistant filter media construction allows for easier breathing over long periods of wear.

Part #	Description
3M8212	N95, Welding, 10/BX

3M™ 8233 N100



Particulate respirator for those who want maximum filter efficiency in a maintenance free respirator. This product has been certified by NIOSH to provide at least 99.97% filter efficiency against solid and liquid particles (excluding those containing oil). This respirator can be used when grinding, welding, working with lead, or situations where arsenic or cadmium are present up to 10X the OSHA PEL. Value added features such as adjustable straps, 3M™ Cool Flow™ Exhalation Valve and a comfortable face seal make this a comfortable, durable respirator.

Part #	Description
3M8233	N100, Exhale Valve, 1/BG



3M™ 8246 R95



Particulate respirator with 3M recommended nuisance level (below OSHA PEL) acid gas relief such as hydrogen fluoride, sulfur dioxide and chlorine. For use in primary aluminum and glass etching industries. The respirator filter is NIOSH certified to provide at least 95% filter efficiency against solid and liquid particles including those containing oil. Not to be used in situations where the exposure exceeds the OSHA PEL. Time use restrictions may apply.

Part #	Description
3M8246	R95, Nuisance Acid Gas, 20/BX

3M™ 8247 R95



Particulate respirator with 3M recommended nuisance level organic vapor relief. For use in applications such as foundries, undercoating, petrochemical operations and agricultural situations where particles are present with concentrations of organic vapors below the OSHA PEL. The respirator filter is NIOSH certified to provide at least 95% efficiency against solid and liquid particles including oils. Time use restrictions may apply.

Part #	Description
3M8247	R95, Nuisance Organic Vapor, 20/BX

3M™ 8511 N95



Particulate respirator is NIOSH certified to have at least 95% filter efficiency at removing solid and liquid particles (excluding those containing oil). The innovative "M" nose clip helps provide a good seal against the face. The 3M™ Cool Flow™ Exhalation Valve reduces heat and humidity build up inside the respirator. Workers will appreciate the added comfort and durability found in this respirator.







Part #	Description
3M8511	N95, Exhale Valve, 10/BX

Respiratory Protection



3M™ 5000 SERIES MAINTENANCE-FREE RESPIRATORS

Designed for comfort and preassembled for convenience, 3M 5000 Series maintenance-free respirators are lightweight, well-balanced, and come in 3 color-coded sizes for quick identification.

Respirator	Part #	NIOSH Approvals
	3M5101 (Small) 3M5201 (Medium) 3M5301 (Large)	Certain Organic Vapors (a)(b)
	3M5102 (Small) 3M5202 (Medium) 3M5302 (Large)	Chlorine, Hydrogen Chloride, and Sulfur Dioxide or Chlorine Dioxide or Hydrogen Sulfide (escape Only) (a)(b)
	3M5103 (Small) 3M5203 (Medium) 3M5303 (Large)	Certain Organic Vapors, Chlorine, Hydrogen Chloride, and Sulfur Dioxide, or Hydrogen Sulfide (escape Only) or Hydrogen Fluoride (a)(b)
	3M5104 (Small) 3M5204 (Medium) 3M5304 (Large)	Ammonia and Methylamine(a)(b)
	3M5105 (Small) 3M5205 (Medium) 3M5305 (Large)	Formaldehyde and Certain Organic Vapors (a)(b)(c)
	3M51913 (Small) 3M52913 (Medium) 3M53913 (Large)	P100/Certain Organic Vapors, Chlorine, Hydrogen Chloride, and Sulfur Dioxide, or Hydrogen Sulfide (escape only) or Hydrogen Fluoride (a)(b)
	3M51P71 (Small) 3M52P71 (Medium) 3M53P71 (Large)	P95/Certain Organic Vapors (a)(b)

- (a) All 5000 Series respirators and respirator/filter assemblies can be used up to the NIOSH approval limits, 10 times the permissible exposure limit, or the maximum use concentration allowable in applicable OSHA standards, whichever is lower.
- (b) For specific usage, limitations and warning information, see respirator and/or filter packaging, or call 3M OH&ESD Technical Service, 1-800-243-4630.
- (c) OSHA regulations require that gas proof goggles be worn with half facepiece respirators when used against formaldehyde.

3M™ 6000 SERIES LOW MAINTENANCE RESPIRATORS

3M 6000 Series respirators are some of the most lightweight, and well-balanced respirators available. Made for a comfortable fit with soft, lightweight facepiece material, three facepiece sizes and easy-to-adjust headstraps. Since the 6000 series respirators are so lightweight, comfortable and easy to use, workers are more open to using it. The 6000 series respirator requires only limited maintenance time. Clean as directed between uses.

6000 SERIES HALF FACEPIECE RESPIRATORS

6000 Series Half Facepiece Respirators are not typical reusable respirators because they have no parts to replace (except filters and cartridges). The initial cost is just a little more than a disposable respirator, but the savings grow through reuse of the facepiece. There is no retainer or extra parts needed to attach the cartridges to the facepiece. The 6000 series respirator can be disassembled, cleaned and reused many times. NIOSH approved.

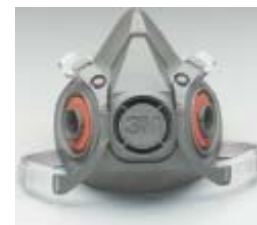

6000 SERIES FULL FACEPIECE RESPIRATORS

Like the half mask respirators, the 6000 Series Full Facepiece respirators require no retainers or extra parts to attach filters, cartridges or dual airlines. The large lens provides excellent visibility, and the hard-coated lens reduces scratches that can impair vision. The large field of vision and comfort-fit features mean workers are more willing to wear the respirator. The 6000 Series respirator is NIOSH approved for negative pressure air purifying and positive pressure dual airline applications.









Part #	Description	Size
3M6100	Respirator, Half Facepiece, Low Maintenance, Gray	Small
3M6200	Respirator, Half Facepiece, Low Maintenance, Gray	Medium
3M6300	Respirator, Half Facepiece, Low Maintenance, Gray	Large
3M6700	Respirator, Full Facepiece, Low Maintenance, Gray	Small
3M6800	Respirator, Full Facepiece, Low Maintenance, Gray	Medium
3M6900	Respirator, Full Facepiece, Low Maintenance, Gray	Large

Respiratory Protection

3M™ 6000 SERIES CARTRIDGES & FILTERS

See notes (a), (b), (c)











Cartridge	Cartridge #	NIOSH Approval
	3M6001	Certain Organic Vapors
	3M6002	Chlorine, Hydrogen Chloride, and Sulfur Dioxide or Chlorine Dioxide or Hydrogen Sulfide (escape Only)
	3M6003	Certain Organic Vapors, Chlorine, Hydrogen Chloride, and Sulfur Dioxide or Hydrogen Sulfide (escape Only) or Hydrogen fluoride
	3M6004	Ammonia and Methylamine
	3M6005	Formaldehyde** and certain Organic Vapors
	3M6006	Certain Organic Vapors, Chlorine, Hydrogen Chloride, Chlorine Dioxide, Sulfur Dioxide, Hydrogen Sulfide (escape only), Ammonia/Methylamine, Formaldehyde** or Hydrogen Fluoride.
	3M6009	Mercury Vapor or Chlorine Gas



Part#	Description
3M2091	Filter, P100, Particulate, 2/BG
3M7093	Filter, P100, Particulate, 10/BX
3M5N11	Filter, N95, Particulate, 10/BX

Part#	Description
3M0501	Filter Retainer, 20/PK
3M0502	Filter Adapter, 20/PK

Cartridge #	NIOSH Approval
	3M60921 P100/Certain Organic Vapors
	3M60922 P100/Chlorine, Hydrogen Chloride, and Sulfur Dioxide or Chlorine Dioxide or Hydrogen Sulfide (escape only)
	3M60923 P100/Certain Organic Vapors, Chlorine, Hydrogen Chloride, Sulfur Dioxide, or Hydrogen Sulfide (escape only) or Hydrogen Fluoride
	3M60924 P100/Ammonia and Methylamine.
	3M60925 P100/Formaldehyde** and Certain Organic Vapors
	3M60926 P100/Certain Organic Vapors, Chlorine, Hydrogen Chloride, Chlorine Dioxide, Sulfur Dioxide, Hydrogen Sulfide (escape only) Ammonia/Methylamine, Formaldehyde** or Hydrogen Fluoride.
	3M60928 P100/Organic Vapor/Acid Gas
	3M60929 P100/Mercury Vapor or Chlorine Gas

**OSHA regulations require that gas-proof goggles be worn with half facepiece respirators when used against formaldehyde.

6000 FULL FACEPIECE RESPIRATOR NIOSH APPROVALS FOR USE LIMITATIONS

- (a) All 6000 Series full facepiece respirator/cartridge/filter assemblies can be used up to the NIOSH approval limits, 50 times the permissible exposure limit (PEL), or the maximum-use concentration allowable in applicable OSHA standards, or applicable government regulations, whichever is lower.
- (b) For specific use, limitations and warning information, see respirator and filter packaging, or call 3M OH&ESD Technical Service, 1-800-243-4630. In Canada, call 1-800-265-1840, ext. 6137 or 1-519-452-6137.
- (c) NIOSH 42CFR84 approved filters and prefilters:
 N95 Filter: At least 95% efficient against solid and liquid aerosols that do not contain oil.
 P100 Filter: At least 99.97% efficient against solid and liquid aerosols including oils.



Respiratory Protection



POWERED AIR PURIFYING RESPIRATOR FACE-MOUNTED POWERFLOW™

The 3M™ Powerflow™ Face-Mounted Powered Air Purifying Respirator's weight is evenly distributed for a comfortable and secure fit. The low profile design provides a good field of vision and makes working in tight spots easier. The face-mounted PAPR uses a single HEPA filter for protection against particulate contaminants such as dusts, mists, fumes and radionuclides, making it ideal for lead, asbestos and other hazardous particulate environments.

SUGGESTED APPLICATIONS

- Abatement
- Nuclear/utilities
- Smelting
- Lead reclamation
- Pharmaceutical
- Foundry/steel
- Nuclear

USE FOR:

- Respiratory protection against particulate contaminants such as dusts, fumes, and mists.
- Radionuclides and radon daughters attached to particles.
- Respiratory protection against asbestos-containing dusts and mists.

FEATURES & BENEFITS

- NIOSH approved
- Meets impact and penetration requirements of ANSI Z87.1-1989 (eye and face protection).
- Positive pressure, constant flow
- Facepiece-mounted motor/airflow unit
- Lightweight, compact, mobile
- Rechargeable Nickel Cadmium battery pack (Battery chargers are sold separately).
- Up to eight hours continuous battery use
- Easily decontaminated

Part #	Description	Size
3M6800PF	Powerflow® Face-mounted PAPR, 1 facepiece/bx, 4 facepieces/cs	M
3M6900PF	Powerflow® Face-mounted PAPR, 1 facepiece/bx, 4 facepieces/cs	L
3M450-01-01R20	SP3 HEPA Filter, 20 pack	
3M520-03-73*	Battery charger, single battery unit	
3M520-03-72*	Battery charger, five battery unit	
3M520-01-61*	Battery charger, ten battery unit	

*Battery chargers are sold separately

⚠ WARNING !

These respirators help reduce exposure to certain airborne contaminants. Misuse may result in sickness or death. Before use, the wearer must read and understand User Instructions provided as a part of product packaging. Time use limitations may apply. Call 3M OH&ESD Technical Service.

IMPORTANT: Before using these respirators, you must determine the following:

1. The type of contaminant(s) for which the respirator is being selected.
2. The concentration level of contaminant(s).
3. Whether the respirator can be properly fitted on the wearer's face. All respirator instructions, warnings and use and time limitations must also be read and understood by the wearer before use.

IF YOU DON'T SEE THE 3M RESPIRATOR OF YOUR CHOICE

ASK AN

PowerPlus EXPERIENCED TEAM MEMBER

FOR MORE INFORMATION!

Respiratory Protection



2200 SERIES N95

PARTICULATE RESPIRATORS WITH DURA-MESH™ SHELL
Collapse-resistant Dura-Mesh™ shell lasts longer so workers use fewer masks. Shaped for comfort with contour molded nose-bridge. Seals easily and comfortably without a metal nose-band. Certified under NIOSH 42CFR84 to have filter efficiency level of 95% or greater against particulate aerosols free of oil. Flame-retardants added to help decrease flammability of shell. NIOSH Approval: TC-84A-0327



Part #	Description
2200N95	Dura-Mesh™, Medium/Large 20/BX

2300 SERIES N95

PARTICULATE RESPIRATORS WITH EXHALE VALVE
Use for most welding fumes. Exhale valve reduces hot-air build-up to keep workers cooler and more comfortable. Collapse-resistant Dura-Mesh™ shell lasts longer so you use fewer masks. Flame-retardants added to help decrease flammability of shell. Shaped for comfort with contour molded nose-bridge. Seals easily and comfortably without a metal noseband. Certified under NIOSH 42CFR84 to have filter efficiency level of 95% or greater against particulate aerosols free of oil. NIOSH Approval: TC-84A-0328



Part #	Description
2300N95	Particulate Respirators, M/L, 10/BX

2310 N99 PREMIUM

PARTICULATE RESPIRATOR FOR MOST WELDING FUMES
Exhale valve reduces hot-air build-up. Keeps workers cooler and more comfortable. Collapse resistant Dura-Mesh™ shell lasts longer so workers use fewer masks. Flame-retardants added to help decrease flammability of shell. Shaped for comfort with contour molded nose-bridge. Soft foam nose seal fits easily and comfortably without a metal noseband. Certified under NIOSH 42CFR84 to have filter efficiency level of 99% or greater against particulate aerosols free of oil. NIOSH Approval: TC-84A-1459



Part #	Description
2310N99	Premium, One Size, 10/BG

2400N95

PARTICULATE RESPIRATOR PLUS NUISANCE LEVELS OF OZONE AND ORGANIC VAPORS - Use for most welding fumes. Added sorbent helps filter out nuisance levels of ozone and organic vapors (less than OSHA PEL). Exhale valve reduces hot-air build-up and keeps workers cool and comfortable. Collapse-resistant Dura-Mesh™ shell lasts longer so workers use fewer masks. Flame-retardants help decrease flammability of shell. Shaped for comfort with contour molded nose-bridge. Seals easily without a metal noseband. Certified under NIOSH 42CFR84 to have filter efficiency level of 95% or greater against particulate aerosols free of oil. NIOSH Approval: TC-84A-0883



Part #	Description
2400N95	Particulate Respirator, 10/BG



Respiratory Protection

AMBIENT AIR BREATHING SYSTEMS

FULL MASK SYSTEMS

The Full Mask Systems provide a portable air source for one, two or three respirator users. They include one, two or three comfortable full mask supplied air respirators, a 1/3 hp ambient air pump, 3/4 hp pump or 1 1/2 hp pump and 50 or 100 foot breathing air hose.

System Components

Part #	Description
9200-01	One worker Full Mask System with 50' hose
9210-01	One worker Full Mask System with 100' hose
9200-02	Two worker Full Mask System with 50' hose
9210-02	Two worker Full Mask System with 100' hose
9200-03	Three worker Full Mask System with 50' hose
9210-03	Three worker Full Mask System with 100' hose



FULL MASK 1 USER SYSTEM



FULL MASK 2 USER SYSTEM

ALLEGRO INDUSTRIES has developed a complete line of supplied air respirators systems and equipment for workers in confined space and contaminated environments. They began over 10 years ago selling ambient pumps and their expertise in supplying clean, breathable air has grown to the development of complete respirator systems. Their complete one, two, or three worker ambient air pumps, MSHA-NIOSH approved continuous flow masks or hoods and air hose. All in one box. With a part number. What could be simpler?

HALF MASK SYSTEMS

The Half Masks System offer portable, lightweight air sources for one, two or three workers. They are offered with one, two or three comfortable half mask supplied air respirators, a 1/3 hp ambient air pump, 3/4 hp pump or 1 1/2 hp pump, and 50' or 100' breathing air hose.

System Components

Part #	Description
9205-01	One worker Half Mask System with 50' hose
9215-02	One worker Half Mask System with 100' hose
9205-02	Two worker Half Mask System with 50' hose
9215-02	Two worker Half Mask System with 100' hose
9205-03	Three worker Half Mask System with 50' hose
9215-03	Three worker Half Mask System with 100' hose



HALF MASK 3 USER SYSTEM



Respiratory Protection

CARRY-AIR AND WALL-AIR FILTRATION PANELS



Allegra's Air Filtration Panels convert shop air used for pneumatic tools and equipment to clean breathable air. They provide from 1 to 5 airline respirators a portable source of up to 30 or 60 cfm of breathable air from 5-125 psig. The 3-stage filtration system purifies compressed air removing water, oil and particulate contaminants. An optional carbon monoxide monitor, which can be operated in AC or DC mode, activates an audible alarm when the concentration of CO exceeds 10 ppm (set for 5 ppm in Canada). The pressure regulator includes a pressure gauge and adjustment knob with locking ring. An adjustable pressure relief valve protects the CO monitor and respirators in the event of regulator failure. The Carry-Air AC/DC-powered unit is housed in a rugged Pelican case for portability and protection. It includes a support stand for stability and up-right operation. An AC/DC powered Wall-Mount unit is also available. Available with and without CO monitors. Both models meet NIOSH requirements for point-of-attachment.

9872-40



9872



2 - WORKER

Part#	Description
9872	Carry-Air w/CO Monitor
9872-40	Wall-Air w/CO Monitor
9872W/O	Carry-Air w/out CO Monitor
9872-40W/O	Wall-Air w/out CO Monitor

5 - WORKER

Part#	Description
9875	Carry-Air w/CO Monitor
9875-40	Wall-Air w/CO Monitor
9875W/O	Carry-Air w/out CO Monitor
9875-40W/O	Wall-Air w/out CO Monitor

8 - WORKER

Part #	Description
9878	Carry-Air w/CO Monitor
9878-40	Wall-Air w/CO Monitor
9878-W/O	Carry-Air w/out CO Monitor
9878-40 W/O	Wall-Air w/out CO Monitor

FILTRATION PANEL SPECS

FILTRATION PANELS	PART #	MAX. FLOW	MAX. INLET	DIMENSIONS	WEIGHT (LBS)
Carry-Air 2 Worker	9872 Series	30 cfm	150 psig	13"x12"x6"	11
Carry-Air 5 Worker	9875 Series	60 cfm	150 psig	16"x13"x7"	15
Carry-Air 8 Worker	9878 Series	100 cfm	150 psig	22"x15"x7"	24
Wall-Air 2 Worker	9872-40 Series	30 cfm	150 psig	20"x9"x7"	11
Wall-Air 5 Worker	9875-40 Series	60 cfm	150 psig	20"x9"x7"	13
Wall-Air 8 Worker	9878-40 Series	100 cfm	150 psig	20"x9"x7"	17

NOTE: All above air sources come standard with Foster/Hansen couplers. Other couplers available on request.

Respiratory Protection

FIT TEST PRODUCTS BY



STANDARD BANANA OIL KIT - 0203

For quick fit testing the standard kit contains two 1 oz. bottles of test agent, vinyl test enclosure, measuring pipette, and paper towels in a handy carry bag.



DELUXE BANANA OIL KIT - #0202

Iso Amyl Acetate (banana oil) offers the oldest method of testing respirator fit. Its strong, readily identifiable odor will be recognized if respirators don't obtain a fit. The kit includes all the equipment necessary to perform a proper fit test, including a fit test tent, jars, 8 oz. testing agent, paper towels, disposable bags and other necessary components, all housed in a convenient storage and carry case.



RESPIRATOR FIT CHECK AMPULES - 0201

Provides a fast, safe and easy method to perform qualitative respirator fit check. When activated, the ampules give off a non-irritating odor of banana oil (Iso Amyl Acetate). If banana odor is detected by the wearer, the respirator must be adjusted or replaced. 10 ampules per box.



STANDARD SMOKE TEST KIT - 2050

For qualitative fit testing of air purifying respirators, this Smoke Test Kit offers everything needed for meeting OSHA's protocol for fit testing with smoke. Includes irritant smoke tubes, aspirator assembly, and record form in a protective carry pouch.



DELUXE SMOKE TEST KIT - 2055

The Deluxe Pump Smoke Test Kit includes a smoke fit tube pump with batteries which generates the required 200 ml per minute of smoke, six smoke tubes with caps, and instructions.



RESPIRATOR FIT TEST TENT - 2060

Creates a concentrated area for qualitative fit testing. The tent features two openings for convenient respirator adjustment. A saturated towelette can be clipped and hung inside the tent when using it for an Iso Amyl Acetate test. Made of nylon reinforced material with a viewing window. 48" high and 24" diameter. Warning: Do not use tent with Irritant Smoke Test.

Part #	Description
0202	Deluxe Banana Oil Kit
0202-0 1	8 oz. Replacement Solution for Deluxe Banana Oil Kit
0203	Standard Banana Oil Kit
0203-01	1 oz. Replacement Solution for Standard Banana Oil Kit
2050	Standard Smoke Test Kit
2050-01	Replacement Tubes 6/box for both Smoke Kits
2055	Deluxe Smoke Test Kit
2060	Respirator Fit Test Tent

RESPIRATOR CLEANING PADS

Large (5" x 8"), individually foil-packaged towelettes contain 70% Isopropanol and are designed specifically for rubber respirator facepieces and other personal safety equipment. The box is designed as a dispenser. 100 Towelettes per box.

Part #	Description	Size
ARW	Respirator Cleaning pads	100/BX



Respiratory Protection

PREMAIRE® SUPPLIED-AIR RESPIRATOR SYSTEM

The PremAire Supplied-Air Respirator System is one of the most advanced air-line respirators available. Designed to provide the utmost in versatility, the modular system allows users to “create” different respirator configurations from one unit. As a result, workers can use the PremAire System to match specific respiratory protection needs to the task at hand. A lightweight, mask-mounted regulator provides high air flow and responds quickly to changing breathing requirements. The basic PremAire Respirator includes the patented manifold and can be upgraded with any of the four following options:

- (1) an Escape Cylinder that permits emergency escape from Immediately Dangerous to Life and Health (IDLH) atmospheres.
- (2) a Dual-Supply option that lets workers connect from one pressurized continuous air source to another without losing continuity of air flow.
- (3) a Duo-Twin option that converts the respirator into a combination supplied-air/air-purifying device. This option allows workers in non-IDLH atmospheres to move freely from station-to-station without being tethered to an air-supply hose.
- (4) a Vortex Tube option that delivers whole-body temperature control for added worker comfort.

The PREMARE® Respirator is a full-face, pressure-demand, Type-C supplied-air respirator with a patented waist-mounted manifold that gives it incredible flexibility. Featuring five individual ports, the manifold makes it possible to add any of these capabilities:

- Supplied-air respirator with emergency-escape air cylinder for egress from IDLH atmospheres.
- Combination supplied-air/air-purifying respirator, which lets you move freely from station to station without being tethered to an air-supply hose, yet still be protected by the device’s air-purifying capability.
- Supplied-air respirator with dual-supply capability — an MSA exclusive that eliminates the need to drag long lengths of air-supply hose around the work area.
- Supplied-air respirator with vortex tube, which provides body cooling, or warming, whenever protective clothing is required.

No matter what option you choose, you’ll find that the PremAire System provides dependable protection, engineering excellence and cost-effective versatility.



Fully Configured PremAire Manifold

THE ASSEMBLE-TO-ORDER SYSTEM

MSA offers more PremAire System Respirator choices than ever before. All totalled, there are thousands of possible combinations so that workers can select just the right PremAire for the job.

MSA’s new Assemble-To-Order System (ATO) will make ordering the right unit easier and faster than ever. Instead of choosing from a handful of complete PremAire assemblies, users can order a custom-made unit with every option exactly as desired. As shown on the following pages, the ATO System works by allowing users to create their own part numbers. Each digit of an ATO part number will represent a specific component, so that the entire part number represents a finished respirator built exactly to the desired specifications.



TWO WAYS TO ORDER

The ATO System

Using the ATO System (on the following page) is easy. The user selects the number or letter that corresponds to the choice of components and fills in the appropriate box. A number or letter from each category must be selected. For example, to order a PremAire System respirator with nylon belt assembly, right-hip 10-minute composite escape cylinder, dual-supply option with 8-inch hose, a non-NFPA, medium, black Hycar Ultra Elite with large noseclip and large EZ-Don Head Harness, Foster steel quick-disconnect and a hard side carrying case, the ATO part number would be the following: B-PS1310-11M24-G-1.

Traditional MSA Part Numbers

For customers who require faster delivery, the most popular PremAire system combinations can still be ordered with a traditional MSA part number. These units are always stocked in our warehouse and are ready to ship upon receipt of order.

Part #	Description
496823	Complete Assembly, Less Case
496896	Complete Assembly, 5 Minute Composite Cylinder, Right-Hip Model, With Case
497291	Complete Assembly, 10 Minute Composite Cylinder, Right-Hip Model, With Case

Advantages of the ATO System include:

- You get the exact model of PremAire you need
- No special orders, because all orders are customized
- Fresher cylinders from our continually rotated inventory
- Simplified ordering process
- Timely delivery

Respiratory Protection

PREMAIRE SYSTEM UPGRADE KITS



ESCAPE CYLINDER KITS

Part #	Description
800696	Kit with Fully-Wound Composite 5 Minute Cylinder, For Right Hip
800694	Kit with Fully-Wound Composite 5 Minute Cylinder, For Left Hip
800697	Kit with Fully-Wound Composite 10 Minute Cylinder, For Right Hip
800695	Kit with Fully-Wound Composite 10 Minute Cylinder, For Left Hip

VORTEX TUBE KITS

Part #	Description
800706	Kit with 6 inch Hose, Cool-Only Version
800710	Kit with 6 inch Hose, Warm/Cool Version
801012	Kit with 12 inch Hose, Cool-Only Version
801014	Kit with 12 inch Hose, Warm/Cool Version

DUAL-SUPPLY KIT

Part #	Description
800044	Dual Supply Kit, Includes 8 inch Hose, Less Quick-Disconnect Assembly

DUO-TWIN* KITS

Part #	Description
800978	Kit with Hycar Rubber Facepiece
800980	Kit with Black Silicone Facepiece

* Duo-Twin Kits are stocked with medium size facepieces. Small and large size facepieces are available as special order items.



PREMAIRE AIRLINE FILTER KIT

Part #	Description
811940	PremAire Airline Filter Kit

REPLACEMENT PREMAIRE RESPIRATOR FACEPIECES

ULTRA ELITE® FACEPIECES WITH EZ-DON HARNESS, LESS NOSECUP.

Part #	Description
817307	Ultra Elite, Hycar, Black, Small
817308	Ultra Elite, Hycar, Gray, Small
817309	Ultra Elite, Silicone, Black, Small
817310	Ultra Elite, Silicone, Gray, Small
817304	Ultra Elite, Hycar, Black, Medium
814020	Ultra Elite, Hycar, Gray, Medium
817305	Ultra Elite, Silicone, Black, Medium
817306	Ultra Elite, Silicone, Gray, Medium
815662	Ultra Elite, Hycar, Black, Large
815664	Ultra Elite, Hycar, Gray, Large
817311	Ultra Elite, Silicone, Black, Large
817312	Ultra Elite, Silicone, Gray, Large

ULTRAVUE® FACEPIECES

WITH RUBBER HARNESS, LESS NOSECUP.

Part #	Description
817313	Ultravue, Hycar, Black, Small
817316	Ultravue, Silicone, Black, Small
817314	Ultravue, Hycar, Black, Medium
817317	Ultravue, Silicone, Black, Medium
817315	Ultravue, Hycar, Black, Large
817318	Ultravue, Silicone, Black, Large

PREMAIRE® CADET SUPPLIED-AIR RESPIRATOR

The PremAire Cadet Respirator is a pressure-demand, Type C, supplied-air respirator with a mask-mounted regulator that responds quickly to wearer's changing breathing requirements. Available in two models, the respirator can serve as a basic supplied-air device or, with the Duo-Twin option, function as a combination air-line/air-purifying respirator. It can easily be upgraded to the versatile, state-of-the-art PremAire System.

Designed for a variety of applications, PremAire Cadet Respirators can be used in non-IDLH (Immediately Dangerous to Life or Health) environments only. Operating inlet pressure is 60-100 psig. NIOSH/MSHA approved.

Part #	Description
811015	Complete Assembly with Medium Black Hycar Ultra Elite Facepiece, in Case
810951	Complete Assembly with Medium Black Hycar Ultra Elite Facepiece, less Case
496858	Complete Assembly with Medium Hycar Ultravue Facepiece, in Case
496780	Complete Assembly with Medium Hycar Ultravue Facepiece, less Case
496854	Complete Assembly with Medium Hycar Duo-Twin Facepiece, in Case
496784	Complete Assembly with Medium Hycar Duo-Twin Facepiece, less Case

SYSTEM UPGRADE

To upgrade the PremAire Cadet to the advanced PremAire System, users simply install the patented PremAire System manifold assembly to the existing PremAire Cadet Respirator. Positioned near the wearer's waist, the manifold serves as an "air distribution center" for the entire system, while also permitting use of all PremAire System options.

Part #	Description
496697	PremAire Manifold Assembly (includes O-ring, Snap-Tite Quick-Disconnect Socket and belt bracket)



Respiratory Protection

CONSTANT FLOW AIR-LINE RESPIRATOR

Constant Flow Air-Line Respirators are designed to maintain a slight positive pressure of air inside the facepiece whether the wearer is inhaling or exhaling. This helps prevent contaminants from seeping in around the facepiece, even if there should be small breaks in the face-to-facepiece seal. The complete respirator assembly is available with either an Ultravue or Ultra Elite Full-Facepiece, Comfo Half-Mask Facepiece or Comfo Welder's Facepiece, breathing tube, web support belt, and air-flow control valve with quick-disconnect assembly. The Constant Flow Respirator is used in non-IDLH environments. NIOSH/MSHA approved.

Complete Assemblies

Choose facepiece, control valve and quick-disconnect assembly. Comes with breathing tube and a web support belt. For optional PVC (polyvinylchloride) belt, order Part No. 473902.



High-Pressure Control Valve (35-40 psig inlet pressure for 8-300 ft of hose)

Part #	Description
810829	Assembly, High Pressure Control Valve, Quick-Disconnect, Snap-Tite Aluminum, Ultra Elite Facepiece
460863	Assembly, High Pressure Control Valve, Quick-Disconnect, Snap-Tite Aluminum, Ultravue Facepiece
460865	Assembly, High Pressure Control Valve, Quick-Disconnect, Snap-Tite Aluminum, Comfo Facepiece
460862	Assembly, High Pressure Control Valve, Quick-Disconnect, Snap-Tite Aluminum, Welders Comfo Facepiece
810831	Assembly, High Pressure Control Valve, Quick-Disconnect, Foster Steel, Ultra Elite Facepiece
480464	Assembly, High Pressure Control Valve, Quick-Disconnect, Foster Steel, Ultravue Facepiece
461719	Assembly, High Pressure Control Valve, Quick-Disconnect, Foster Steel, Comfo Facepiece
480600	Assembly, High Pressure Control Valve, Quick-Disconnect, Foster Steel, Welders Comfo Facepiece
810834	Assembly, High Pressure Control Valve, Quick-Disconnect, Duff-Norton Brass, Ultra Elite Facepiece
486258	Assembly, High Pressure Control Valve, Quick-Disconnect, Duff-Norton Brass, Ultravue Facepiece
810833	Assembly, High Pressure Control Valve, Quick-Disconnect, Snap-Tite Locking Hard-Coated Anodized Aluminum, Ultra Elite Facepiece

High-pressure control valves are also available with the following special order quick-disconnects: Snap-Tite brass or stainless steel, Foster brass, and Hansen brass or stainless steel. Low-pressure control valves also available with: Snap-Tite brass or stainless steel, Foster brass, Hansen brass, and Duff-Norton brass.



LOW-PRESSURE CONTROL VALVE (10-15 PSIG INLET PRESSURE FOR 8-50 FT OF HOSE)

Part #	Description
806775	Assembly, Low Pressure Control Valve, Quick-Disconnect, Snap-Tite Aluminum, Ultra Elite Facepiece
463300	Assembly, Low Pressure Control Valve, Quick-Disconnect, Snap-Tite Aluminum, Ultravue Facepiece
463302	Assembly, Low Pressure Control Valve, Quick-Disconnect, Snap-Tite Aluminum, Comfo Facepiece
463281	Assembly, Low Pressure Control Valve, Quick-Disconnect, Snap-Tite Aluminum, Welders Comfo Facepiece
806776	Assembly, Low Pressure Control Valve, Quick-Disconnect, Foster Steel, Ultra Elite Facepiece
480472	Assembly, Low Pressure Control Valve, Quick-Disconnect, Foster Steel, Ultravue Facepiece
806779	Assembly, Low Pressure Control Valve, Quick-Disconnect, Hansen Brass, Ultra Elite Facepiece
484836	Assembly, Low Pressure Control Valve, Quick-Disconnect, Hansen Brass, Ultravue Facepiece
484837	Assembly, Low Pressure Control Valve, Quick-Disconnect, Hansen Brass, Comfo Facepiece

PORTAIRE™ PORTABLE AIR-SUPPLY SYSTEM

The PortAire System holds two standard SCBA air cylinders to provide firefighters, industrial personnel, confined-space workers and other wearers of respiratory protective equipment with a portable, compressed-air source anytime an air-line device is required. Designed for use with MSA pressure-demand supplied-air respirators, including dual-purpose self-contained breathing apparatus (SCBA), the PortAire System consists of a compact air-pressure regulating system housed in a lightweight, yet durable, anodized aluminum frame.

PORTAIRE PORTABLE AIR-SUPPLY SYSTEM

Part #	Description
807052	PortAire Portable Air Supply System, Audi-Larm Low Pressure Warning Device, High Pressure Regulator, Carrying Frame & Hose
807053	Quick-Fill Kit



Respiratory Protection

PORTAIRE™ PORTABLE AIR-SUPPLY SYSTEM (CONTINUED)

CYLINDERS

Part #	Description
807588	Cylinder, Stealth H-60 (4500 psig), 60 Minutes
807570	Cylinder, Stealth H-45 (4500 psig), 60 Minutes
807587	Cylinder, Stealth H-30 (4500 psig), 60 Minutes
807002	Cylinder, High-Pressure (4500 psig), 60 Minute Kevlar
801285	Cylinder, High-Pressure (4500 psig), 60 Minute Fully-Wound Composite
806933	Cylinder, High-Pressure (4500 psig), 45 Minute Kevlar
801287	Cylinder, High-Pressure (4500 psig), 30 Minute Fully-Wound Composite
807586	Cylinder, Stealth L-30 (2216 psig), 30 Minutes
469619	Cylinder, Low-Pressure (2216 psig), 30 Minute Hoop-Wrapped
809872	Cylinder, Low-Pressure (2216 psig), 30 Minute 3AL (Aluminum)
801279	Cylinder, Low-Pressure (2216 psig), 30 Minute Composite II
816115	Cylinder, Stealth L-30+ (3000 psig), 30 Minutes
801289	Cylinder, Low-Pressure (3000 psig), 30 Minutes Composite II

MANIFOLDS

Required when using multiple (2-4) respirators from a single air source; these manifolds have quick-disconnect assemblies with automatic shut-off outlets.



Manifolds

Part #	Description
47370	Manifolds, 4 Outlets, Foster Quick-Disconnect
84416	Manifolds, 2 Outlets, Foster Quick-Disconnect
93931	Manifolds, 4 Outlets, Snap-Tite Quick-Disconnect
486053	Manifolds, 2 Outlets, Snap-Tite Quick-Disconnect

AIR-LINE RESPIRATOR ACCESSORIES

APPROVED AIR-SUPPLY HOSE

MSA ³/₈-inch ID Air-Supply Hose is available in smooth, reinforced, lightweight polyvinylchloride, chemical-resistant black neoprene, or smooth, coiled nylon. Must be used with respirators in this section to maintain NIOSH certifications.



AIR-SUPPLY HOSE

Temperature Ranges

Neoprene = -25° to 212° Fahrenheit

PVC = 32° to 120° Fahrenheit

Nylon = 0° to 160° Fahrenheit

INLET PRESSURE GAUGE

MSA offers an inlet pressure gauge that enables a user to check pressure at the inlet of the MSA Air-Supply Hose, thereby assuring that air pressure is within the certified range. The gauge is supplied with Quick-Disconnect fittings.



Part #	Description
455022	Air Supply Hose, Neoprene, Brass Fittings, 50'
455021	Air Supply Hose, Neoprene, Brass Fittings, 25'
455020	Air Supply Hose, Neoprene, Brass Fittings, 15'
481071	Air Supply Hose, Neoprene, Brass Fittings, 8'
481080	Air Supply Hose, Neoprene, Stainless Steel Fittings, 50'
481079	Air Supply Hose, Neoprene, Stainless Steel Fittings, 25'
481078	Air Supply Hose, Neoprene, Stainless Steel Fittings, 15'
481077	Air Supply Hose, Neoprene, Stainless Steel Fittings, 8'
484225	Air Supply Hose, PVC, Brass Fittings, 100'
471513	Air Supply Hose, PVC, Brass Fittings, 50'
471512	Air Supply Hose, PVC, Brass Fittings, 25'
471511	Air Supply Hose, PVC, Brass Fittings, 15'
481051	Air Supply Hose, PVC, Brass Fittings, 8'
481060	Air Supply Hose, PVC, Stainless Steel Fittings, 50'
481059	Air Supply Hose, PVC, Stainless Steel Fittings, 25'
481058	Air Supply Hose, PVC, Stainless Steel Fittings, 15'
481057	Air Supply Hose, PVC, Stainless Steel Fittings, 8'
474043	Air Supply Hose, Coiled Nylon, Brass Fittings, 50'
491515	Air Supply Hose, Coiled Nylon, Brass Fittings, 25'
491514	Air Supply Hose, Coiled Nylon, Brass Fittings, 15'
491513	Air Supply Hose, Coiled Nylon, Brass Fittings, 8'
696014	Hose/Breathing Tube Cover, 200' RL

* Recommended usable length, 4-25 ft.

Part #	Description
476734	Inlet Pressure Gauge, Snap-Tite Fitting
476735	Inlet Pressure Gauge, Foster or Schrader Fitting
476736	Inlet Pressure Gauge, Duff-Norton Fitting



Respiratory Protection

QUICK-DISCONNECTS FOR AIR-LINE RESPIRATORS AND AIR-SUPPLIED HOODS

Quick-disconnect assemblies connect air-supply hoses to the manifold and to the air source. If you want to use a quick disconnect to interconnect lengths of air supply hose, you must use a locking type quick disconnect—specifically, the locking quick disconnects listed on the bottom of this page.

Quick-Disconnects and Adapters

Quick-Disconnect Type	Female Socket 1/4" NPT	Male Plug w/ Female 1/4" NPT	Union Adapter 1/4" NPT x 3/4" UNF	Male Plug w/ Male 1/4" NPT (used when connecting Inlet Pressure Gauge)	Female Socket Assem. (used to connect Air-Supply Hose to Male Plug on Respirator)
Snap-Tite (AL)	66272	66274	69542	66273	455019
Snap-Tite (SST)	629673	629672	808358	629671	471778
Snap-Tite (BR)	630305	630307	69542	630306	471777
Duff-Norton (BR)	630308	630310	69542	630309	471780
Hansen (SST)	628768	628208	808358	473502	471779
Hansen (BR)	630311	630313	69542	630312	471501
Foster (S)	628770	55716	69542	56549	467044
Foster (SST)	636459	636460	808358	636461	801016
Foster (BR)	629980	629981	69542	473501	470194
CEJN Locking (Chrome-plated BR)	631870	479026	69542	479020	479001
CEJN Locking (Chrome)	—	479026	69542	479020	476956
Snap-Tite Locking (AL)	—	479027	69542	479021	479032
Snap-Tite Locking (SST)	—	479028	808358	479022	479033
Snap-Tite Locking (BR)	—	479029	69542	479023	479034
Foster Locking (SST)	636473	637851	808358	—	800805

LOCKING QUICK-DISCONNECTS

Locking quick-disconnects must be used to interconnect lengths of MSA Air-Supply Hose. For most systems, you can use up to 12 sections of hose to make up the maximum length.

Part #	Description
479009	CEJN Locking Quick-Disconnect Assembly, Socket & Plug (Chrome)
476956	CEJN Locking Female Quick-Disconnect Socket (Chrome)
476955	CEJN Locking Male (w/Male 1/4" NPT) Quick-Disconnect Plug (Chrome)
479010	Snap-Tite Locking Quick-Disconnect Assembly, Socket & Plug (AL)
479032	Snap-Tite Locking Female Quick-Disconnect Socket (AL)
479015	Snap-Tite Locking Male (w/Male 1/4" NPT) Quick-Disconnect Plug (AL)
479011	Snap-Tite Locking Quick-Disconnect Assembly, Socket & Plug (SST)
479033	Snap-Tite Locking Female Quick-Disconnect Socket (SST)
479016	Snap-Tite Locking Male (w/Male 1/4" NPT) Quick-Disconnect Plug (SST)

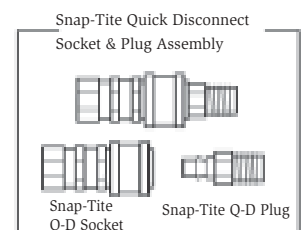
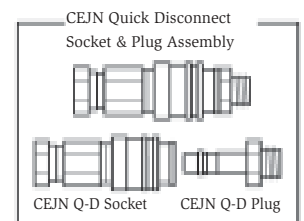

Respiratory Protection

THE BREATHER BOX™

The Breather Box™ series filters inlet air to provide respirator wearers Grade-D quality air and meets the new 1910.134 dew point criteria. **Specifications:** Filter change indicators on all three filters, automatic drains in 1st and 2nd stage, 0 - 160psi pressure gauge, adjustable pressure regulator, preset relief valve, visual flow meter and durable polycarbonate case that can be wall mounted. In-line Carbon Monoxide Monitor with visual and high intensity audible alarm. Available in 50 and 100cfm versions. **Permanent Panel Mounting Applications** are available in 50 or 100 cfm versions. Custom sizes are available up to 3000cfm.

The Auto-Air Breather Box™ has been designed for work in IDLH or hazardous environments where positive pressure breathing air must always be assured. In the event of electrical failure, or if the main line air pressure drops below 60 psi, this unit automatically switches to any reserve air source. Should this occur, audible and visual alarms activate.

Available Options on all Models: CO/O2 monitor for dual monitoring. Intrinsically safe models. Remote audible and/or visual alarms.



Model
BB50-CO

Part #	Description
BB50-CO	Breather Box, Standard, 50 cfm, 4 Couplings
BB50-CO4R	Breather Box, 50 cfm, 4 Independent Regulators
BB50-COAA	Breather Box, Auto-Air, 50 cfm, 4 Couplings
BB50-COPM	Grade-D Filtration, Panel Mounted, 50 cfm

(100 cfm and custom options available on all models)

PORTABLE BREATHING AIR COMPRESSORS

The low pressure breathing air compressors are portable oil-less air sources for use with Type-C constant flow respirators only (0-15psi). They are available for 2, 3, 4, 6, or 8 person use.

Part #	Description
BAC-10	Ambient Air Compressor, Low Pressure, 2-Person
BAC-17	Ambient Air Compressor, Low Pressure, 3-Person
BAC-20	Ambient Air Compressor, Low Pressure, 4-Person
BAC-20P	Ambient Air Compressor, Low Pressure, Pneumatically, 4-Person



Model BAC-17



PORTABLE COOLING AIR DISTRIBUTION MANIFOLD

The COOL-BOX™

The revolutionary COOL-BOX™ provides low cost cool air anywhere and can operate with any airline Type-C mask or hood style respirator. Ideal for cooling Level "A" chemical suits and air supplied hoods. Provides cool air for up to four workers. Attaches easily to any plant air or mobile compressor, and eliminates the need and expense of noisy vortex cooling tubes. Provides NIOSH point-of-attachment components and cooling in one package. **Specifications:** Provides approximately 50°F air temperature with input temperatures up to 180°F and 75 cfm flow capacity. Requires 20 lbs. of ice for 4 to 8 hours of operation. Attaches to any Grade-D compressed air source up to 150 psi. Adjustable pressure regulator,

Part #	Description
BACB-196	Cool-Box, with 1/4" Hansen or Schrader Fittings
BACB-196LP	Cool-Box, Designed Specifically for Use with Ambient Air Pumps Only (Maximum 20psi Inlet)



Model BACB-196LP with
Optional Ambient Air Pump

MULTI-PAK™

The MULTI-PAK™ series of small bottles air carts has been designed with the user in mind. Choose from any basic designs to fit the simplest or most complex job application. All of the small MULTI-PAK™ carts feature fold-down handles, recessed air control panels, rounded cart corners, quick release hose racks, and many other features.

Part #	Description
MP-2L	MULTI-PAK™, 2-bottled air cart, 2400 psi, supplied with 2-outlet manifold CGA-346 wrench-tight nuts
MP-2H	MULTI-PAK™, 2-bottled air cart, 4500 psi, supplied with 2-outlet manifold CGA-347 hand-tight nuts
AC-60	Optional, 60cf Aluminum Cylinder, 2216 psi
AC-87	Optional, 87cf Fully Wrapped Cylinder, 4500 psi
MP-C	Optional, Nylon cart cover for small MP series carts



The MULTI-PAK™

Respiratory Protection

OVERVIEW OF AIR MASKS

MSA offers Air Masks in two design variations—the mask-mounted regulator (MMR) model and belt-mounted regulator model. Both are available in low-pressure (2216 or 3000 psig) and high-pressure (4500 psig) versions and can be customized with a variety of air cylinders for regular and extended-use applications. All MSA Air Masks comply with the requirements of the National Institute for Occupational Safety and Health (NIOSH), and the Mine Safety and Health Administration (MSHA). The Ultralite MMR and Custom 4500 MMR and Ultralite II and Custom 4500 II SCBAs comply with ANSI/NFPA-1981, 1992 edition.

MMR XTREME™ AIR MASK

Sleek, rugged and lightweight, the MMR Xtreme Air Mask is the future of self-contained breathing apparatus (SCBA). It has the best of everything—from its comfortable, wide-vision Ultra Elite facepiece and clean, low-profile mask-mounted regulator with large shutoff button, to its high-strength yet remarkably lightweight cylinder options and advanced Black Rhino carrier/harness assembly. MMR Xtreme Air Masks represent the collection of choice for unparalleled performance.

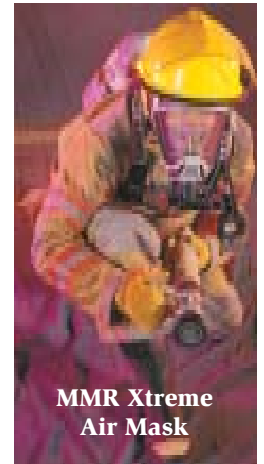

MMR Xtreme Air Mask

ULTRALITE® MMR AND CUSTOM 4500® MMR SCBA

With MSA MMR Air Masks, performance is enhanced by a unique split-regulator design. The regulator's first stage is located on the cylinder backplate, while the second stage attaches to the user's facepiece. The low-pressure Ultralite MMR Air Mask can be used with cylinders pressurized to either 2216 psig or 3000 psig. The Custom 4500 MMR Air Mask is used with 4500 psig cylinders. All MMR units can be easily upgraded to include the Quick-Fill® option for emergency escape breathing support system (EEBSS) plus fast, convenient refilling of cylinders. For added versatility of MMR Air Masks, dual purpose conversion kits are available, providing the capabilities of an air-line respirator and SCBA in one. Cylinder choices remain the same.



Custom 4500 MMR SCBA

ULTRALITE® II AND CUSTOM 4500® II SCBA

Ultralite II and Custom 4500 II Air Masks are similar in versatility to their MMR counterparts, but feature a belt-mounted regulator. Available with unique Quick-Fill option for emergency escape plus fast, convenient refilling of cylinders. Ultralite II and Custom 4500 II Air Masks are also available in dual-purpose versions, which combine the capabilities of an SCBA and an air-line respirator in one unit.



Ultralite II SCBA



Work Mask MMR SCBA

WORKMASK™ II AND WORKMASK™ MMR SCBA

The WorkMask II and WorkMask MMR Self-Contained Breathing Apparatuses (SCBA) are economical, lightweight and durable units designed for use in industrial environments that do not require compliance with NFPA-1981. The WorkMask II and WorkMask MMR SCBAs are not designed for firefighting. An optional Dual-Purpose version combines the capabilities of an SCBA and an air-line respirator for greater versatility.



SEE ORDERING INFORMATION ON THE FOLLOWING PAGES.

Respiratory Protection

CYLINDERS



FIBERGLASS FULLY-WOUND
These lightweight models feature a fiberglass outerwrap and are available in low- and high-pressure versions, including a low-profile model for confined spaces work.



FIBERGLASS HOOP-WOUND
Available in a 30-minute low-pressure model, MSA's hoop-wound cylinder features fiberglass wrapping and provides a cost-saving advantage over fully-wound composites.



STEALTH
Stealth Cylinders are the lightest SCBA air cylinders ever developed by MSA.



KEVLAR FULLY WOUND
Lighter in weight than equivalent fully wound fiberglass cylinders, these cylinders use ultrahigh-strength Kevlar fibers.



3AL
Less expensive than MSA's Hoop-Wound cylinder, this 30-minute low-pressure cylinder features all-aluminum construction.

Cylinder Type (Cylinder & Valve)	NIOSH Service Life Rating	Pressure	Weight* (Empty)	Part #
Stealth L-30	30-minute	2216 psig	7 lb.-9 oz.	807586
Stealth L30 +	30-minute	3000 psig	7 lb.-9 oz.	816115
Kevlar Fully-Wound	30-minute	3000 psig	9 lb.-14 oz.	801289
Fiberglass Fully-Wound	30-minute	2216 psig	9 lb.-14 oz.	801279
Fiberglass Hoop-Wound	30-minute	2216 psig	13 lb.	469619
Aluminum	30-minute	2216 psig	18 lb.	809872
Stealth H-30	30-minute	4500 psig	7 lb.-3 oz.	807587
Fiberglass Fully-Wound	30-minute	4500 psig	11 lb.-1 oz.	801287
Stealth H-45	45-minute	4500 psig	10 lb.-9 oz.	807570
Kevlar Fully-Wound	45-minute	4500 psig	12 lb.-3 oz.	806933
Stealth H-60	60-minute	4500 psig	12 lb.-11 oz.	807588
Kevlar Fully-Wound	60-minute	4500 psig	14 lb.-12 oz.	807002
Fiberglass Fully-Wound	60-minute	4500 psig	18 lb.-9 oz.	801285

THE DRAGONFLY SA PASS: READY WITH YOU AT THE STARTING LINE

When the moment strikes, you jump to action. You need a stand-alone PASS that activates as immediately as you do.

That's why the DragonFly SA PASS features a tethered key designed to be attached to your jump seat, locker or vehicle interior. When you jump to action, the key snaps off, and your DragonFly SA PASS activates and is on guard, monitoring your every move. Once the job is complete, you can turn your stand-alone PASS off by the two steps required by NFPA-1982, 1998: simply replace your key and press reset twice.

The DragonFly SA PASS is adjustable to accommodate different thicknesses of belts. It can also "clip on" to turnout gear, if preferred.

No matter what your needs, MSA now offers two new PASS options designed to deliver exceptional performance.

A PASS Alarm that Feels the heat.

When the heat is on, the DragonFly device's operational heat sensor will make sure you know it. The temperature-sensing unit (thermistor) measures heat on a time-weighted average. This design is based on the guideline that 180° F for 18 minutes is just as hazardous as 600° F for one minute. At either extreme, and for every temperature in between, the device will sound an alarm to alert you that dangerous heat levels are looming.

Part #	Description
10005048	DragonFly IP PASS, with heat sensor
10005049	DragonFly IP PASS, without heat sensor
10009767	DragonFly IP PASS, with heat sensor and low-pressure gauge
10009766	DragonFly IP PASS, without heat sensor, with low-pressure gauge
10009769	DragonFly IP PASS, with heat sensor and high-pressure gauge
10009768	DragonFly IP PASS, without heat sensor, with high-pressure gauge
10005071	DragonFly SA PASS, with heat sensor
10005072	DragonFly SA PASS, without heat sensor



Respiratory Protection

WALKAWAY MOUNTING BRACKET

This storage unit can be mounted with screws on rescue or fire vehicles or any permanent surface. The spring clips permit the wearer to strap on the apparatus unassisted. By stepping forward, the wearer snaps out of the bracket.



Part #	Description
39851	Walkaway Mounting Bracket for Ultralite II, Ultralite MMR or Custom 4500 II or Custom 4500 MMR Mask w/ 30 Minute Cylinder

WALL-MOUNTED CASE

Corrosion-resistant, tough, plastic case has a leakproof synthetic rubber bulb seal gasket; protects breathing apparatus from sunlight, weathering, dust and corrosive atmospheres.



Part #	Description
695308	Wall-Mounted Case for Ultralite II & Ultralite, MMR, 30 Minute
695796	Wall-Mounted Case for Custom 4500 II & Custom MMR, 30 Minute
695797	Wall-Mounted Case for Custom 4500 II & Custom MMR, 60 Minute

SPECTACLE KIT FOR FULL FACEPIECE RESPIRATORS

For use by workers who must wear corrective lenses, the Spectacle Kit can be easily inserted into the facepiece. The kit includes a wire support, rubber guide and pair of metal-frame spectacles. Desired adjustment is obtained by moving the spectacles in and out of the rubber guide and up and down the wire support. One size of spectacle frame is used (S-7 shape, 44-mm lens size) with Universal Bridge Corrective Lenses that can be obtained from local sources. The Spectacle Kit can be used in conjunction with a noseclip. There are two kits for the Ultra Elite facepiece; one uses a side wire support to hold the lenses in the facepiece while the other uses a center support to position the unit (spectacle adjustments are similar).



Spectacle Kit for Ultravue Facepiece

Part #	Description
804638	Ultra Elite Spectacle Kit (side wire support)
493581	Ultra Elite Spectacle Kit (center support)
454819	Ultravue Facepiece Spectacle Kit



Side Support Spectacle Kit for Ultra Elite Facepiece



Center Support Spectacle Kit for Ultra Elite



ESP® COMMUNICATIONS SYSTEM

The ESP Communications System is a one-piece voice projection device for Ultra Elite Facepieces used on MSA Air Masks. Using the ESP Communications System, firefighters can speak normally, allowing the ESP unit to project their voice so it can be heard, loud and clear. Available in hands-free (on and off) or PTT (Push-To-Talk/on and off) models, the lightweight ESP Communications System maintains the visibility of the Ultra Elite Facepiece. Comfortable to wear and easy to use, the unit's rugged construction provides resistance to water, flame, heat and impact. It is compatible with fire departments' existing handheld radios for clear, long-range communications. A standard nine-volt alkaline battery powers the unit (not included) and will last up to eighteen hours before it needs to be replaced. An ESP Communication System Conversion Kit is also available for Ultravue Facepieces.



ESP System Conversion Kit for Ultravue® Facepiece (Battery not included)

ESP System for Ultra Elite Facepiece (Battery not included)

Part #	Description
817296	Ultra Elite ESP with PTT (Push-To-Talk/On and Off Switch), Low Battery Indicator
817297	Ultra Elite ESP (On and Off Switch Only)
817374	Pressure Demand Component Housing Cover
817373	Demand Component Housing Cover

Part #	Description
811737	Conversion Kit



GLOVE MATERIALS



LEATHER

For protection from rough objects, sparks and heat, and for cushioning from blows in heavy duty work requirements. All kinds of leather provide comfort, durability, dexterity, mild heat resistance and abrasion protection. These advantages make leather a traditional favorite for industrial workers.

STYLES & PATTERNS

LEATHER PALMS, GUNN PATTERNS - For protection from rough objects, sparks, heat and cushioning from blows in heavy duty work requirements.

LEATHER PALMS, CLUTE PATTERS - Greatest economy offering leather protection.

DRIVERS - Allow more dexterity when operating heavy machinery and vehicles.

WELDERS - Provide protection for welding and heat applications.

MIG/TIG WELDERS - afford a fine touch in low heat applications.

TYPES OF LEATHER

COW - Cow leather is the most commonly used leather within the glove industry due to its plentiful availability. The United States and Australia produce the majority of these hides. The advantages include comfort, durability, excellent abrasion and breathability. Chrome tanning of this leather provides greater wear and heat resistance.

PIG - Pigskin offers the greatest breathability due to the porous texture of this hide. Additionally, pigskin tends to become softer with use and withstands moisture without stiffening. When laundered, this leather will return more to its natural soft texture than other leathers.

GOAT - Independent tests have proven this to be a stronger and more durable leather. The natural lanolin produced by goats help to create the softest, most abrasion resistant leather. This leather is highly recommended for applications requiring tactile sensitivity.

CUTS OF LEATHER

GRAIN - Grain Leather is the smooth external side of the hide. This type of leather provides durability and dexterity.

SPLIT - Split leather is the rougher internal side of the hide. The different types of split will be side, shoulder, or belly split.

- **SIDE SPLIT**-comes from the rib area of the animal. This part of the leather is the most durable and provides the greatest protection because of its greater density of fibers.
- **SHOULDER SPLIT**-is more economical than side, but less durable. The additional movement of the animal in this shoulder area creates less fibers and a more visible texture difference.
- **BELLY SPLIT**- is the most economical; however, it has the least consistency of texture and appearance.

FULL FEATURE GUNN PATTERN



WITH LEATHER PALM

This select shoulder leather palm glove is for tough, rugged jobs where you need extra protection against abrasion. Available in assorted styles for specific job applications, this glove features a rubberized cuff for durability and a full feature Gunn style for comfort. This glove is ideal for landscaping, construction, farming, iron and steel work, assembly and general purpose work requiring leather protection.



Part #	Description	Sizes
1310	Full Feature Gunn, 4 1/2", Gauntlet Cuffs	S-XL
1311	Double Leather Palm, 2 1/2", Safety Cuffs	Large

FULL FEATURE GUNN PATTERN



This economy shoulder leather palm glove features a full Gunn pattern for comfort and fit. Available with rubberized safety cuff or starched safety cuff, this glove is ideal for general purpose applications requiring abrasion protection and breathability of leather and cotton. Industry applications include assembly, construction, fabrication, landscaping, maintenance, metal working, mining and sanitation.



Part #	Description	Sizes
1200	2 1/2", Rubberized Safety Cuffs	Large
1200S	2 1/2", Starched Safety Cuffs	Large

DOUBLE LEATHER PALM



This Double Leather Palm glove features a full Gunn pattern for comfort and fit. Available with a 2 1/2" rubberized safety cuff, this glove is ideal for general purpose applications requiring abrasion protection and breathability of leather and cotton. Industry applications include assembly, construction, fabrication, landscaping, maintenance, metal working, mining and sanitation.



Part #	Description	Size
1211	2 1/2", Rubberized Safety Cuffs	Large

FULL FEATURE GUNN PATTERN



This economy shoulder leather palm glove features a full Gunn pattern for comfort and fit. Available with a 2 1/2" denim cuff, this glove is ideal for general purpose applications requiring abrasion protection and breathability of leather and cotton. Industry applications include assembly, construction, fabrication, landscaping, maintenance, metal working, mining and sanitation.



Part #	Description	Sizes
1220D	2 1/2", Denim Cuffs	Large



3440L

REFLECTIVE GRAIN PIG DRIVER

Pigskin affords the greatest breathability due to the porous texture of this hide. Additionally, pigskin tends to become softer with use and withstands moisture without stiffening. When laundered, this leather will return more to its natural soft texture than other leathers.

Part #	Description	Size
3440L	Reflective Grain Pig Driver with 3M® Reflective Tape, Thermosock Lining, 2.5" Knit Wrist	Large
1440L	Reflective Safety Leather Palm with 3M® Reflective Tape, 2.5" Safety Cuffs	Large

New Product



1440L

REFLECTIVE SAFETY LEATHER PALM

INDUSTRY APPLICATIONS: This high visibility glove is suited for all applications where being visible is important for safety. General purpose applications requiring abrasion protection and breathability of leather and cotton.

Hand Protection



3200

COW GRAIN LEATHER DRIVERS

- FULL LEATHER GLOVES
- PREMIUM GRAIN LEATHER
- SLIP-ON CUFFS
- COLOR CODED HEMS TO IDENTIFY SIZES

INDUSTRY APPLICATIONS

Operators for construction equipment, farm equipment, fork lifts, ranching, tank truck and tractor trailer operators, utility workers, plus all general purpose applications requiring greater dexterity.



3211

Part #	Description	Sizes
3200	Shirred Elastic Back, Premium Grade, Unlined, Straight Thumb	S - XL
3201	Shirred Elastic Back, Regular Grade, Unlined, Straight Thumb	S - XL
3211	Shirred Elastic Back, Regular Grade, Unlined, Keystone Thumb	S - XXXL

GRAIN GOAT SKIN DRIVERS



This glove has a shirred elastic back and is made of goatskin. Use in industry applications demanding both durability and dexterity, also farming industry, construction, casting, steel and iron work, municipalities and utilities.



Part #	Description	Sizes
3601	Shirred Elastic Back, Straight Thumb	S - XXXL

MUSTANG® MIG TIG WELDERS



Mig Tig and heli-arc welding, and any other application requiring dexterity. Made with premium grain leather and sewn with Dupont® Kevlar thread along with Split leather gauntlet cuffs.



Part #	Description	Sizes
4950	Mig Tig, Welders Leather Palm	M - XL

SPLIT COW WELDERS



This welding glove is made of shoulder leather, with a one piece leather back and is fully welted. A full sock lining, in-sewn at all finger tips and has leather hems.



Part #	Description	Size
4150	Welding, Gunn Pattern glove	Large

BLUE BEAST®



This Welding Glove is made of Premium Side Leather. It is sewn with Dupont Kevlar® thread and has a self hemmed leather cuff for longer wear. It has a fully enclosed sock lining made from soft jersey fleece material for extra comfort and absorption. The sleeves are lined with flame-retardant material. Also, this glove is fully welted to reinforce all critical wear areas.



Part #	Description	Sizes
4600	Reinforced Thumb and Palm	OS



GLOVE MATERIALS



SUPPORTED

FOR PROTECTION AGAINST CHEMICALS, ABRASION, CUTS AND PUNCTURES.

CONSTRUCTION

CUT-N-SEWN

Cut-N-Sewn synthetic gloves are made from fabric that has been coated, impregnated or laminated with a chemical solution, such as nitrile or vinyl, before being cut.

DIPPED

All dipped gloves are created by dipping canvas, interlock, jersey or knitted shells into a polymer such as neoprene, nitrile, PVC, rubber or vinyl or a combination of these polymers.

CUFF STYLES

Cuff styles vary depending on the needs for specific applications. The most common are: safety cuffs, gauntlet cuffs, band top, knit and slip-on.

POLYMERS

NEOPRENE-greater flexibility plus broad chemical protection.

NITRILE-excellent abrasion resistance.

PVC-liquid and solvent protection.

RUBBER-gripping power, cut and puncture resistance.

VINYL-breathable, easy gripping, minimizes absorption of water, oil and grease.

COTTON-For comfort and breathability in general purpose applications and in heavier weights, for abrasion and heat protection.

LIGHT WEIGHT (PRODUCT PROTECTION)

INSPECTORS-cotton or nylon, reversible, may be used as gloves or glove liners.

SINGLE PLY (MULTI-PURPOSE)

CANVAS-8 oz., 10 oz., or 12 oz. fabric for general purpose work. PVC dots provide gripping ability and longer wear.

JERSEY-9-oz. jersey for general purpose work. PVC dots provide gripping ability and longer wear.

TERRY CLOTH-seamless knit styles in various weights for specific degrees of heat protection.

QUILTED (HEAVY MULTI-PURPOSE PLUS HEAT PROTECTION)

CHORE-general purpose work

DOUBLE PALM-minimal heat protection

HOT MILL-moderate heat protection

UNSUPPORTED

UNSUPPORTED STYLES OFFER GREAT DEXTERITY IN APPLICATIONS REQUIRING CHEMICAL PROTECTION. THE MIL MEASUREMENTS IDENTIFIES THE THICKNESS OF A GLOVE IN THE PALM AREA. A MIL IS 1/1000TH OF AN INCH.

REGULAR UNSUPPORTED--11 mil-30 mil thicknesses

LATEX-canners and flocked-lined; natural rubbers is the most elastic substance known.

NITRILE-unlined and flocked-lined, provides cut, snag, puncture and abrasion resistance better than any others polymer.

NEOPRENE-flock-lined, resists oils and offers less hand fatigue

NEOPRENE ON LATEX-flock-lined, unique construction provides protection against harsh chemicals.

NEOPRENE AND LATEX BLEND-flock-lined, 85% Latex, 15% Neoprene blend provides versatility for multiple applications.

DISPOSABLE UNSUPPORTED--1.25-8 mil thicknesses

LATEX-medical or industrial grade, better dexterity, elasticity, cool and comfortable.

VINYL-medical or industrial grade, durability, softness, no-latex allergens.

NITRILE-industrial grade, two-to-three times more puncture and snag-resistant than latex.

STRINGS

For general purpose work applications and for cut abrasion resistance using high performance yarns when working with sharp objects. Various weights provide longer durability or additional dexterity where needed.

MULTI-PURPOSE YARNS

100% Cotton

Cotton/Polyester

100% Polyester

100% Synthetic

100% Nylon

100% Thermastat

PVC COATING-provides

better grip and longer wear

HIGH-PERFORMANCE YARNS

KEVLAR® Knits

STAINLESS STEEL-Steelcore II

SPECTRA FIBER-Survivor

CONSTRUCTION

KNIT PATTERNS-STRINGS

An additional benefit of the seamless construction of string knits is their reversible pattern. String knits are constructed with natural yarn fibers (such as 100% cotton/polyester) or high performance yarn fibers, such as KEVLAR®, Spectra®, stainless steel or combinations of these materials for maximum abrasion and cut protection.

Hand Protection



CONSOLIDATOR®

Slip-on style with Nitrile (NBR) rubber coating on soft interlock cotton lining then cut and sewn into a snug pattern to allow maximum dexterity. This glove is puncture resistance with extra abrasion and cut resistance, along with chemical splash resistance but is not waterproof.



Part #	Description	Sizes
9700	Consolidator, Slip-On Style, Mens	M - XXL
9710	Consolidator, Slip-On Style, Ladies	S - L



WHIZZBEE™

This vinyl dipped glove features a slip-on style and porous textured coating which allows for breathability and easy gripping while minimizing the absorption of water, oil and grease and is treated with ACTIFRESH®. The Whizzbee features a soft two-piece 100% cotton jersey lining with a seam-out construction. Ideal for small parts handling, construction, electronics assembly, shipping, receiving, assembly, maintenance, light fabrication, inspection and packaging.



Part #	Description	Sizes
9892	Whizzbee™, Jersey Lined, Seams Out pattern	S - L



PREMIUM DOUBLE-DIPPED PVC

This Premium Double-Dipped PVC green glove has a jersey lining and is treated with ACTIFRESH®. Industry applications for the green colored glove include oils and solvents, petrochemicals and refining. This glove is manufactured with a special blend of high quality plasticizers and resins for maximum flexibility and chemical protection.



Part #	Description
6412	Premium, Double-Dipped PVC, Jersey lined, 12" gauntlet
6414	Premium, Double-Dipped PVC, Jersey lined, 14" gauntlet

R = rough finish
SJ = sandpaper finish, jersey lined

WHIZZBANG™

This vinyl-coated glove has a two-piece interlock liner and is treated with ACTIFRESH®. This versatile glove is ideal for small parts handling, construction, electronics assembly, shipping, receiving, assembly, maintenance, light fabrication, inspection and packaging.



Part #	Description	Sizes
9890	Whizzbang™, Two-Piece Interlock Liner	S - L

PREMIUM DOUBLE-DIPPED PVC

This double dipped PVC glove has a jersey lining and is fully coated. With generous sizes available, ideal uses for this glove include basic liquid, mild chemical protection, auto industry, construction, and mining. The economy glove has a rough finish, provides liquid and basic chemical protection for refining, mining and utilities, petrochemicals, fishing, ship building, handling abrasive materials coated with grease and oil, caustics, acids and solvents.



Part #	Description
6212SJ	Premium, Double-Dipped PVC, Jersey lined, 12" Gauntlet
6300SJ	Premium, Double-Dipped PVC, Jersey lined, 14" Gauntlet
6512SJ	Economy, Double-Dipped PVC, Jersey lined, 12" Gauntlet

ECONOMY SINGLE-DIPPED PVC

This economy single-dipped PVC glove has an interlock lining with either a smooth or rough finish. Additional uses include utilities, petrochemicals, fishing, ship building, handling abrasive materials coated with grease and oil, caustics, acids and solvents. Provides liquid and basic chemical protection for refining, mining and utilities, petrochemicals, fishing, ship building, handling abrasive materials coated with grease and oil, caustics, acids and solvents.



Part #	Description
6100	Economy, Single-Dipped PVC, Interlock lined, knit wrist
6212	Economy, Single-Dipped PVC, Interlock lined, 12" gauntlet
6300	Economy, Single-Dipped PVC, Interlock lined, 14" gauntlet
6212R	Economy, Single-Dipped PVC, Interlock lined, 12" gauntlet

Hand Protection

MEMPHIS NEOPRENE NEOMAX™

This double-dipped neoprene glove with a sandy finish has 100% cotton interlock lining brushed for extra comfort and absorption. This glove offer the feel and flexibility of rubber with more versatility and provides protection against abrasions, cuts and hazardous chemicals. All NeoMax™ styles are treated with ACTIFRESH®, an antibacterial agent that promotes hygiene and freshness to help retard odors and eliminate germs by controlling bacterial build-up. Industry applications used in are refining and petrochemical industries, electronics, material handling (wet and dry), turning valves, cleaning equipment and degreasing.



Part #	Description	Sizes
6912	Memphis™ Neomax™, sandy finish, gauntlet, 12"	S - XL

TUFFTEX



The TUFFTEX has a rough textured natural rubber coating for greater gripping power and a higher degree of cut resistance along with a crinkle finish. Used in the industry applications that handle sharp edged materials such as glass or metal or highly abrasive items, such as concrete blocks or lumber.



Part #	Description	Sizes
6820	Tufftex™, premium grade cotton canvas shell, plasticized safety cuffs	Large

MEMPHIS UNSUPPORTED PREMIUM QUALITY NITRILE

This unsupported premium quality nitrile glove is 13" in length and has a heavy duty non-slip grip with straight cuffs. Made with FDA-accepted materials for use in food processing applications. Poly packed in pairs/12 pairs per bag. Industry applications include food processing (red meat, poultry, dairy), chemical processing (petrochemicals, oil refining), machine operations, graphic arts, battery manufacturing and maintenance.



Part #	Description	Sizes
5309	Nitrile, 11 mil/unlined	9
5310	Nitrile, 11 mil/unlined	10
5311	Nitrile, 11 mil/unlined	11

DISPOSABLE VINYL



This 5 mil glove has rolled cuffs and is made with FDA-accepted materials for use in food processing applications

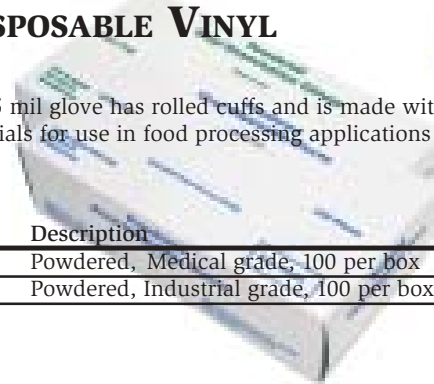

Part #	Description	Sizes
5000	Powdered, Medical grade, 100 per box	S - XL
5020	Powdered, Industrial grade, 100 per box	S - XL

MEMPHIS DISPOSABLE LATEX

This 5 Mil, non-sterile, snug fitting latex glove can be worn on either hand. It is ideal for electronic assembly, food processing, laboratory work and general pharmaceutical use.



Part #	Description	Sizes
5050	Powdered, Medical grade, 100/bx	S - XL
5055	Powder Free, Industrial grade, 100/bx	S - XL
5060	Powdered, Industrial grade, 100/bx	S - XL

FLOCK-LINED LATEX



This general purpose latex glove has a 12" long cuff and heavier weight for better protection. The cuff is beaded for tear resistance and easy pull-on. It is flock lined for comfort and made from flexible, sensitive and strong materials. Ideal for use in the food-processing industries, janitorial work, poultry, and research laboratories.



Part #	Description	Sizes
5280	Latex, Flock-Lined, 18M	8 - 8 1/2
5290	Latex, Flock-Lined, 18M	9 - 9 1/2
5299	Latex, Flock-Lined, 18M,	10 - 10 1/2

Hand Protection



COTTON CANVAS

This 8 oz. cotton canvas work glove is an economical choice for light duty or general purpose applications. Available with a straight thumb and clute pattern, this glove provides reliable abrasion resistance and is a strong, comfortable and soft glove used for general purpose work.

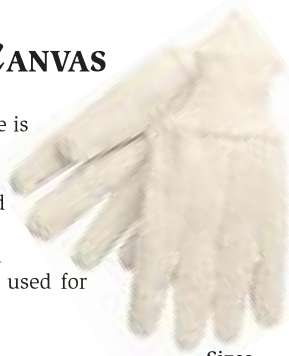

Part #	Description	Sizes
8100	Cotton Canvas, Clute Pattern, Straight Thumb	Mens
8102	Cotton Canvas, Clute Pattern, Straight Thumb	Ladies



JERSEY CLUTE PATTERN

These durable 9 oz. cotton jersey gloves are 100% cotton in a stretchable knit and are for general purpose work.



Part #	Description	Sizes
7100	Jersey Clute Pattern	Mens
7102	Jersey Clute Pattern	Ladies



LIGHTWEIGHT INSPECTORS

These lightweight inspection gloves can be used alone while handling sensitive products or use them as a moisture absorbing glove liner. These gloves feature a two piece ambidextrous pattern and can be laundered for reuse. 100% cotton gloves are unhemmed and reversible.



Part #	Description	Sizes
8600C	Lightweight Inspectors, 100% cotton	Mens
8610C	Lightweight Inspectors, 100% cotton	Ladies

CANVAS DOTS

This 8 oz. heavy napped cotton canvas work glove is an ideal choice for general purpose applications which require additional slip resistance. Available with a dotted palm, index finger and thumb, the plastic dots provide improved slip resistance. This glove also provides reliable abrasion resistance and is a strong, comfortable and soft glove.

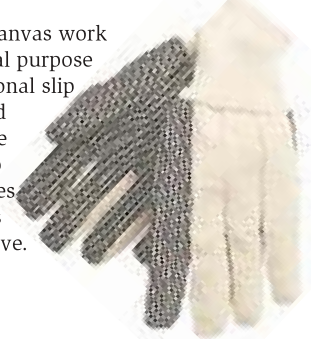

Part #	Description	Sizes
8808	Regular 8 oz. Canvas Dot	Mens

TWO PIECE REVERSIBLE JERSEY

These durable 6.5 oz. reversible jersey gloves are 100% cotton in a stretchable knit and are for general purpose work.



Part #	Description	Sizes
8000I	Two piece reversible Jersey	Mens



DOUBLE PALM, COTTON

These Double Palm gloves are two layers of fabric quilted together for additional wear, low temperature protection and are red-stitched. Ideal uses are for mild protection in automotive plants, farming and foundries.



Part #	Description	Sizes
9018C	Nap-In Double Palm, Cotton, Knit wrist	Mens



STEELCORE II®



The glove is made with dual stainless steel, wrapped with softer nylon yarn for strength and comfortable fit. Cut-resistant, not cut-proof or point-puncture proof. Ideal uses are canning, food processing, glass handling and metal fabricating. Made with FDA-accepted materials for use in food processing.

Part #	Description	Sizes
9350	Steelcore II®, 7 count, regular weight	XS - XL
9356	Steelcore II®, 10 count, medium weight	XS - XL

KEVLAR® KNITS

This glove is made of DuPont KEVLAR® for high tensile strength relative to its weight – up to five times stronger than steel. Will not melt, ignite or conduct electricity. High durability in cut resistance. High comfort level and allows manual dexterity. Made with FDA approved materials for use in food processing applications and can be used as gloves or glove liners.



Part #	Description	Sizes
9390	100% Kevlar Brand fiber, 10-Count Knit, medium weight	S or L



KEVLAR® BRAND FIBER SLEEVES

100% Kevlar® brand fiber sleeves offer complete forearm protection. These 18" sleeves help reduce superficial cuts, abrasions and accidental burns. Other lengths available upon request.



Part #	Description	Sizes
9378T	100% Kevlar® brand fiber, Double Ply Sleeve, with thumb slot,	OS
9378E	100% Kevlar® brand fiber, Plain Sleeve, Economy	OS

STRING KNITS

This glove has a reversible pattern and provides comfort and warmth. String knits allow manual dexterity and all non-coated styles are made with FDA approved materials for use in food processing applications. Ideal uses in refrigerated areas, food processing, automotive industry, general maintenance, parts handling and shipping/receiving.



Part #	Description	Sizes
9500	String, Cotton/Polyester Blend, Regular Weight	S - XL
9638	String, 100% Cotton, Light weight	S - L



COATED STRING KNIT

Coated string knit gloves offer improved grip and abrasion resistance with PVC coating on one or two sides. This glove is ideal for use in automotive plants, material handling, bottling industries, package handling and farming.



Part #	Description	Sizes
9660	Cotton/Polyester Blend, Regular weight, Two-sided PVC Dots, Natural color	S or L
9650	Cotton/Polyester Blend, Regular weight, One-sided PVC Dots, Natural color	S or L

HONEY GRIP®

HONEY GRIP® reversible glove offers a unique "tacky" PVC coating which has excellent gripping capabilities and abrasion resistance. This glove is ideal for material handling, roofing, bottling and farm and gardening industries.



Part #	Description	Sizes
9675	Honey Grip®	S - XL

Hand Protection

**New
Product**

FLEX TUFF®

FLEX TUFF® is made of a natural rubber that provides abrasion resistance and an excellent comfort and fit. The textured palm dip works great for extra grip and durability. Ideal industry applications are material handling, glass handling operations, fishing and plywood industries, sanitation, general maintenance.



Part #	Description	Sizes
9680	Flex Tuff, 10 gauge, cotton/polyester shell, maximum flexibility, Textured Latex Palm Dip	S - XL



SILVER SHIELD® / 4H®

Made of a unique, flexible film, Silver Shield® / 4H gloves come in 6 sizes and are available in 14.5" (36.8 cm) length on sizes 6-8, and a 16" (40.6 cm) length on sizes 9-11/12. They are lightweight, ambidextrous and allows for maximum worker protection yet do not contain chemical accelerants that can cause allergic reactions.



APPLICATIONS

Ideal for the aircraft and aerospace industry, petrochemical and refining applications, emergency response and Hazmat clean-up, chemical transporting, handling chlorinated solvents, hydrocarbons, acids and ketones, photo labs, medical labs, handling pesticides and herbicides.

Part #	Description	Length	Size	Case
SSG/6	Silver Shield/4H Gloves	14.5"	6	50 pair/case
SSG/7	Silver Shield/4H Gloves	14.5"	7	50 pair/case
SSG/8	Silver Shield/4H Gloves	14.5"	8	50 pair/case
SSG/9	Silver Shield/4H Gloves	16"	9	50 pair/case
SSG/10	Silver Shield/4H Gloves	16"	10	50 pair/case
SSG/11	Silver Shield/4H Gloves	16"	11/12	50 pair/case

Chemical resistance and permeation chart on each package.

N-DEX®

N-DEX gloves bring new levels of tactile sensitivity, comfort, dexterity and puncture resistance. The unique low-modulus, soft-nitrile formulation of these gloves replaces and outperforms natural rubber and vinyl disposables in a wide variety of applications. They contain no natural rubber proteins. N-DEX gloves are available in both low-powder (non-talc, USP-grade vegetable starch) and powder-free styles for virtually unlimited disposable glove selection. All meet US government CFR 21 specifications and are acceptable for use in food and pharmaceutical applications. Certain styles are Class 1 medical devices. N-DEX's exclusive, patented (US. Patent No. 35.616), low-modulus formulation reduces hand fatigue caused by elastomeric stress and provides much greater puncture resistance than natural rubber and vinyl disposables of comparable millage thickness. N-DEX gloves also resist a broad range of chemicals in many applications where protection from intermittent contact or splash is needed. Although N-DEX gloves conform to the wearer's hand for a precise, comfortable fit, their unique pressure-reduction characteristic actually minimizes hand pressure and fatigue, giving you a cooler and drier feel than you get with natural rubber or vinyl disposables.

N-DEX's intrinsic static-release properties increase product protection, and all N-DEX styles have a special, built-in safety feature: Although extremely puncture resistant, once violated, N-DEX gloves readily tear so the wearer knows the glove should be replaced. Made in USA.

7005 N-DEX® ORIGINAL is 4-mil thick with low-powder, and low-modulus. It is blue, 9¹/₂"-long, ambidextrous, disposable, and made of 100% -nitrile. 100/BX



Part #	Description	Sizes
7005	N-DEX ORIGINAL, Disposable, Low-Powder, 4 Mil	S-XL



8005 N-DEX® PLUS is 8-mil thick, with low-powder, and low-modulus. It is blue, 10"-long, ambidextrous, disposable, and made of 100% -nitrile. 50/BX



Part #	Description	Sizes
8005	N-DEX PLUS, Disposable, Low-Powder, 8-Mil	S-XL

6005PF N-DEX® MEDICAL EXAM is 4-mil thick, powder-free or with low-powder, and low-modulus. It is blue, 9¹/₂"-long, ambidextrous, disposable, and has rolled cuffs. Made of 100% -nitrile. 100/BX Note: 6005PF is a Class 1 medical device.



Part #	Description	Sizes
6005PF	N-DEX MEDICAL EXAM, Disposable, Powder-Free, 4-Mil	S-XL



9905 N-DEX® ULTIMATE Non-Latex is 6-mil thick, powder-free or with low-powder, and low-modulus. It is blue, 11"-long, ambidextrous, disposable, and has rolled cuffs. Made of 100% -nitrile. 100/BX



Part #	Description	Sizes
9905	N-DEX ULTIMATE Disposable, 4-Mil, Low-Powder	S-XL

9005PF N-DEX® LONG CUFF NON-LATEX is 6-mil thick, powder-free, and low-modulus. It is blue, 11"-long, hand-specific (lefts and rights), with a rolled cuff. Disposable, Made of 100% -nitrile. 50PR/BX Note: 9005PF is a Class 1 medical device.



Part #	Description	Sizes
9005PF	N-DEX, Disposable, Powder-Free, 6-Mil	S-XL

NITRI-PRO™

For handling rough, abrasive materials, Nitri-Pro features our exclusive, tough-yet- flexible nitrile (NBR) coating that provides superior cut, puncture, snag and abrasion resistance and excellent resistance to oil and grease. Palm coated with smooth or rough finish for both men and ladies. Recyclable Nitri-Pro is an economical replacement for medium-to-heavy-duty leather palm work gloves. Rough finish provides a good wet grip and extra wear while the smooth finish provides a good dry grip and more flexibility. Nitri-Pro may be your best bet for handling rough castings, cores, extrusions, tubular steel, sheet metal, fabricated metal, lumber, plywood, drywall, concrete blocks, bricks and tile. This nitrile-coated glove complies with 21 CFR, 170- 199 and is acceptable for use in food and pharmaceutical applications. Made in USA.



Part #	Description	Sizes
7000P	Nitrile Palm Coated, Knit Wrist	8, 9, 10

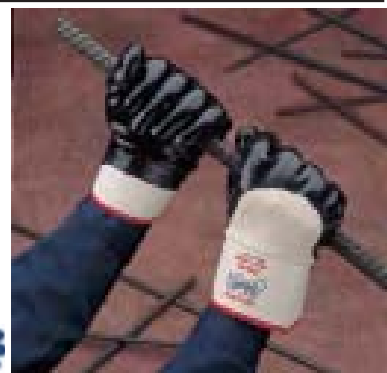

Hand Protection

THE ORIGINAL NITTY GRITTY®

The Original Nitty Gritty was the industry's first wrinkle-finished, natural rubber-coated glove. It remains the most cut resistant, comfortable, premium-value glove of its class. An excellent, cost-effective replacement for leather and ordinary rubber-coated gloves, The Original Nitty Gritty is recyclable and features a soft, five-piece flannel liner which provides greater comfort and flexibility than, jersey-lined gloves. Its multidipped, premium natural rubber coating gives you superior cut, abrasion, snag and puncture resistance and extended wear. The outstanding wet and dry grip provided by the induced self-wrinkle finish enhances safety and ease of handling. The Original Nitty Gritty may be your best bet for handling sharp-edged objects like glass, sheet metal, scrap metal or tin plate, slippery or smooth materials or abrasive objects like lumber, tile, concrete block and brick. This natural rubber-coated glove is in compliance 21 CFR, 170- 199 for use with in both food and pharmaceutical applications. Made in USA.



Part #	Description	Sizes
66NFW	ORIGINAL NITTY GRITTY® Natural Rubber, Palm Coated, Rubberized Safety Cuff	L



ANSWER®

Snug-fitting Answer gloves combine the look and feel of leather with the durability, flexibility, cut, puncture and abrasion resistance of a nitrile-laminated fabric. The Best® transfer-coating process, assures a high-quality lamination that tightly fuses the special nitrile compound to the polycotton base-fabric's exterior so you get greater wear and value. Five-piece construction gives you comfort, stretch, fit and dexterity. For applications where silica contamination is a concern, the answer is talc free. It's launderable, and while not liquid proof, it minimizes absorption of water, oils and greases. Available in mens or ladies medium and large and mens X-large; gloves are color coded for easy size identification and pairing after laundering. The Answer may be your best bet for a broad range of material handling, manufacturing, assembly, light fabricating, receiving, inspection and general plant applications. This nitrile-laminated glove is in compliance 21 CFR, 170- 199 for use with in both food and pharmaceutical applications.



Part #	Description	Sizes
2735	ANSWER® Nitrile, Fully Laminated, Slip-On, Patterned Finish	M - XL



NITRI-FLEX®

This glove is nitrile coated for maximum wear and excellent cut, puncture and abrasion resistance. It features a two piece, 100%-cotton interlock liner for comfort, flexibility and dexterity. Nitri-Flex is an economically versatile alternative to cotton and lightweight leather gloves. Nitri-Flex is recyclable for added value and features a textured grip for safety and ease of handling. Gloves are color coded for easy size identification and pairing after laundering. Nitri-Flex may be your best bet for assembly, shipping and receiving, general maintenance, inspection, material handling and light fabrication. This nitrile-coated glove is in compliance 21 CFR, 170- 199 for use with in both food and pharmaceutical applications. Made in USA.



Part #	Description	Sizes
4000P	NITRI-FLEX® Nitrile, Palm Coated, Interlock Liner, Knit Wrist	S - L



KPG®

Featuring Best's exclusive, breathable, PVC coating on a comfortable, continuous-knit, 100%-cotton liner, abrasion-resistant KPG is cool, flexible and durable. KPG's seam-free liner enhances comfort and eliminates the potential for seam failure. Its textured coating assures you a strong grip, even when handling small parts, and while not liquidproof, it minimizes absorption of water, oil and grease. KPG gives you excellent abrasion resistance, outwearing and readily replacing cotton, lightweight leather, plastic-dot and similar, competitive gloves. KPG is recyclable, and both hands are printed for easy size identification and pairing after laundering. KPG may be your best bet for furniture manufacturing, automotive subassembly, general maintenance, inspection, packaging, shipping, receiving, light fabrication, and general assembly. Made in USA.



Part #	Description	Sizes
960	KPG® PVC, Fully Coated, Seam Free Liner, Slip-On	S - L
961	KPG® PVC, Fully Coated, Seam Free Liner, Knit Wrist	S - L



Fuzzy Duck®

Featuring Best's exclusive, breathable, PVC coating on a soft, comfortable, two-piece jersey liner, cool and abrasion resistant Fuzzy Duck outwears and replaces cotton, light-to-medium-weight leather and goatskin gloves in a wide variety of applications. While not liquidproof, Fuzzy Duck's textured coating provides an excellent grip and minimizes absorption of water, oil and grease. Although not a true anti-vibration (AV) glove, Fuzzy Duck tends to absorb and minimize shock, too. Fuzzy Duck is recyclable and printed on both hands for easy size identification and pairing after laundering. Fuzzy Duck may be your best bet for small parts' handling, general maintenance, shipping, receiving and assembly. Made in USA.

Part #	Description	Sizes
962	PVC, Fully Coated, Jersey Liner, Slip-On	S - XL



FLEX NIT®

Flex Nit features Best's exclusive, breathable PVC coating on a comfortable, two-piece interlock liner. Cool, flexible and abrasion-resistant, Flex Nit easily outwears and replaces ordinary cotton, lightweight leather gloves and similar competitive gloves in many applications. Its textured coating assures a strong grip and, while not liquidproof, it minimizes absorption of water, oil and grease. Flex Nit is recyclable, and both hands are printed for easy size identification and pairing after laundering. Flex Nit may be your best bet for small parts handling, construction, electronics assembly, shipping, receiving, assembly, maintenance, inspection and packaging. Made in USA.

Part #	Description	Sizes
963	PVC, Fully Coated, Interlock Liner, Slip-On	S - L



ULTRAFLEX™ NEOPRENE®

Highly flexible and chemical resistant, this fully coated glove performs well in a wide range of chemicals in which neoprene is recommended, particularly where a lightweight, dexterous glove is needed. It will even withstand complete submersion. Durable and abrasion resistant, it's nearly as flexible as an unsupported glove, yet it's a true coated glove with a strong bond between its neoprene coating and its two-piece interlock liner that enhances glove flexibility and integrity. Ultraflex Neoprene provides an excellent wet grip. It may be your best bet for petrochemicals and refinery applications, turning valves, analyzing samples, handling chemicals, cleaning equipment, electronics, material handling and general utility.

Part #	Description	Sizes
31	Neoprene fully coated, rough finish, 12" gauntlet	M
32	Neoprene fully coated, rough finish, 12" gauntlet	L
33	Neoprene fully coated, rough finish, 12" gauntlet	XL

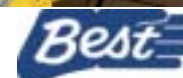

ULTRAFLEX™ NITRILE

This highly flexible, fully coated, chemical-resistant glove provides excellent protection against abrasion, snags and punctures and performs well in a wide range of chemicals. Its rough-finished nitrile coating provides a strong grip, even in liquids. Although it's nearly as flexible as unsupported gloves, Ultraflex Nitrile is a true coated glove with a strong bond between the nitrile coating and the two-piece interlock liner that enhances glove flexibility and integrity. Ultraflex Nitrile provides protection even in case of total emergency submersion of the glove. It may be your best bet for petrochemical and refinery applications, valve turning, maintenance, handling chemicals and general material handling. This glove is in compliance 21 CFR, 170- 199 for use with in both food and pharmaceutical applications. Made in USA.

Part #	Description	Sizes
21R	Nitrile fully Coated, 12" gauntlet, rough finished	M
22R	Nitrile fully Coated, 12" gauntlet, rough finished	L



Hand Protection

NEO GRAB™

This glove is multidipped in premium-grade neoprene for superior quality and durability. It provides protection against acids, caustics, oils, greases and many solvents. Excellent all-around protection against physical hazards such as abrasion and cut. Heavyweight styles have a five-piece flannel liner. Rough-finished styles are available for applications where a good wet grip is required. These gloves may be your best bet for degreasing, petrochemicals, refining, metal fabrication, plating, galvanizing and general material handling. Made in USA.

Part#	Description	Sizes
6780R	Neoprene, fully coated, heavy weight, 12" gauntlet, rough finish	L
6784R	Neoprene, fully coated, heavy weight, 14" gauntlet, rough finish	L
6797R	Neoprene, fully coated, heavy weight, elbow length, rough finish	L



BLACK KNIGHT®

Best's Black Knight gives you the highest value in-use of any black plastic (PVC-coated) glove available. An economical choice for working with chemicals, oil and grease, this Sanitized®, recyclable, abrasion-resistant industry standard may be your best bet for petrochemicals, refining, mining, automotive subassembly, construction and handling slick, abrasive materials. Made in USA.

Part #	Description	Sizes
7703	PVC Fully Coated, Jersey Lined, Knit, Wrist, Smooth Finish	L
7710R	PVC Fully Coated, Jersey Lined, 10" gauntlet, Rough Finish	L
7712R	PVC Fully Coated, Jersey Lined, 12" gauntlet, Rough Finish	L
7714R	PVC Fully Coated, Jersey Lined, 14" gauntlet, Rough Finish	L
7914R	PVC Fully Coated, Interlock liner, 14" gauntlet, Rough Finish	L



NITRI-SOLVE®

Made from a special nitrile (NBR) compound, Nitri-Solve provides excellent protection against abrasion, puncture, cut and snag. It also provides resistance to a broad range of solvents, animal fats and other chemicals. Permeation testing shows that Nitri-Solve's chemical resistance is equal to or better than that of any other similar nitrile glove. Nitri-Solve's case-hardened finish enhances both chemical and abrasion resistance and makes it easy to pull on-and- off. A non-slip grip makes wet work easier, safer, while Nitri-Solve's ergonomic design maximizes comfort. Nitri-Solve is available in flock-lined and unlined styles. Each hand is embossed with glove size for ease of pairing after recycling. Nitri-Solve may be your best bet for food processing (poultry, red meat, fruit, vegetables, dairy), petrochemicals, refining, chemical processing, automotive assembly, painting, machine operations using cutting oil, metal fabrication, drilling, boring, cutting, graphic arts, battery manufacturing, degreasing, electronics, furniture manufacturing and handling pesticides. This unsupported nitrile glove complies with 21 CFR, 170- 199 and is acceptable for use in food and pharmaceutical applications.

Part#	Description	Sizes
730	Unsupported Nitrile, 13", 15-Mil, Non-slip grip, flock lined	7 - 11
737	Unsupported Nitrile, 15", 22-Mil, Non-slip grip, heavy duty, unlined	9 - 11
747	Unsupported Nitrile, 19", 22-Mil, Non-slip grip, unlined	9 - 11



NITRI-MASTER™

Made of Nitrile-natural rubber blend, this glove has a tractor- tread Grip. Unlined and with a straight cuff this glove is excellent for food handling and offers light to medium chemical resistance. In compliance 21CFR,170-199, this glove is made using only listed materials and levels outlined in the Code of Federal Regulations (21CFR), parts 170-199, and is acceptable for use in both food and pharmaceutical applications.

Part#	Description	Sizes
NM08	Unsupported, Nitrile-natural rubber blend, 12" 16-mil, tractor-tread, light green	M
NM09	Unsupported, Nitrile-natural rubber blend, 12" 16-mil, tractor-tread, light green	L
NM10	Unsupported, Nitrile-natural rubber blend, 12" 16-mil, tractor-tread, light green	XL



Hand Protection

CHEM MASTER®

For good resistance to a broad range of chemicals, Chem Master features a neoprene-over-natural rubber construction that also provides excellent abrasion, tear and puncture resistance. This comfortable, flexible and tactile sensitive glove has a self-flushing tractor-tread grip that encourages run off of fluids that are often trapped by a diamond grip pattern. Worker comfort is enhanced by the glove's 100%-cotton flock lining. Glove size is embossed on each hand. Chem Master offers good resistance to acids, alcohols, oils, grease, caustics, salts, ketones, detergents, petroleum-based solvents and animal fats. Chem Master may be your best bet for automotive and battery manufacturing, chemical plants, aircraft assembly, food processing, pesticide manufacturing, plant maintenance and printing clean up. This unsupported neoprene-over-natural rubber glove complies with 21 CFR, 170- 199 to be acceptable for use in food and pharmaceutical applications.



Part #	Description	Sizes
CHM	Unsupported Neoprene-over-natural rubber, flock lined, 13", 26-Mil, sanitized, tractor-tread grip	S - XL

VALUE MASTER™

For good resistance to a broad range of chemicals, Chem Master features a neoprene-over-natural rubber construction that also provides excellent abrasion, tear and puncture resistance. This comfortable, flexible and tactile sensitive glove has a self-flushing tractor-tread grip that encourages run off of fluids that are often trapped by a diamond grip pattern. Worker comfort is enhanced by the glove's 100%-cotton flock lining. Glove size is embossed on each hand. Chem Master offers good resistance to acids, alcohols, oils, grease, caustics, salts, ketones, detergents, petroleum-based solvents and animal fats. Chem Master may be your best bet for automotive and battery manufacturing, chemical plants, aircraft assembly, food processing, pesticide manufacturing, plant maintenance and printing clean up. This unsupported neoprene-over-natural rubber glove complies with 21 CFR, 170- 199 to be acceptable for use in food and pharmaceutical applications.



Part #	Description	Sizes
VMU	Unsupported Natural rubber, unlined, 12", 18-mil, tractor-tread grip, chlorinated, amber	S - XL
VMUP	Unsupported Natural rubber, unlined, 12", 18-mil, tractor-tread grip, chlorinated, blue	S - XL
VM	Unsupported Natural rubber, flock-lined, 12", 18-mil, tractor-tread grip, yellow	S - XL

BEST® BUTYL

This Best unsupported glove is made with Butyl and has a smooth finish. Unlined and with a rolled cuff, this glove is excellent protection against specific chemicals and gases



Part #	Description	Sizes
878	SMOOTH, Unsupported, Butyl, rolled cuff, unlined, 14", 30-mil	M - XXL

IF YOU ARE LOOKING FOR A  GLOVE THAT IS NOT SHOWN, ASK ONE OF OUR

EXPERIENCED TEAM MEMBERS

Protective Clothing



TYPICAL TYVEK PROPERTIES

PHYSICAL PROPERTIES	TEST METHODS	TYVEK 1424A
Basis Weight, oz./sq. yard	ASTM D3776	1.2
Thickness, mils	ASTM D1777	5.5
Strip Tensile, lb/in (MD/CD)	ASTM D1682	7.8/8.9
Work to Break, in/lb (MD/CD)	ASTM D1682	2.5/3.5
Tongue Tear, lb (MD/CD)	ASTM D2261	2.3/2.3
Flammability	16 CFR 1610	Class 1



1412

Tyvek® Coverall, Zipper, set-in sleeve. Meets ANSI/ISEA 101-1996 specifications.



1414

Tyvek® Coverall, Zipper, attached hood and boot, elastic wrists, set-in sleeve. Meets ANSI/ISEA 101-1996 specifications.



1417

Tyvek® Coverall, Zipper, elastic wrists and ankles, set-in sleeve. Meets ANSI/ISEA 101-1996 specifications.

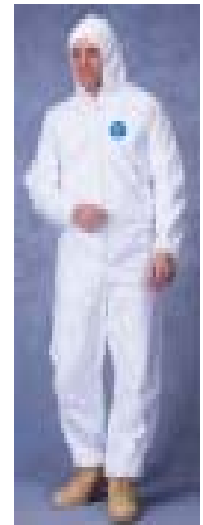

1428

Tyvek® Coverall, Zipper, attached hood, elastic wrists and ankles, set-in sleeve. Meets ANSI/ISEA 101-1996 specifications.



901

Tyvek® shoe cover.



903

Tyvek® boot cover, 17" elastic top.



904

Tyvek® shoe cover, vinyl sole.



905

Tyvek® boot cover, vinyl sole, elastic top.

Part#	Description	Size	Case Pack
1412	Lakeland, Tyvek®, Coverall, collar, zipper, set-in-sleeve	S - 4XL	25/cs
1414	Lakeland, Tyvek®, Coverall, zipper, attached hood & boots, set-in-sleeve, elastic wrist	S - 4XL	25/cs
1417	Lakeland, Tyvek®, Coverall, collar, zipper, set-in-sleeve, elastic wrist & ankle,	S - 4XL	25/cs
1428	Lakeland, Tyvek®, Coverall, zipper, attached hood, set-in-sleeve, elastic wrist & ankle	S - 4XL	25/cs
901	Lakeland, Tyvek®, Shoe Cover	S/M-L/XL	200 pair/cs
903	Lakeland, Tyvek®, Boot Cover, 17" elastic top	S/M-L/XL	200 pair/cs
904	Lakeland, Tyvek®, Shoe Cover, vinyl sole	S/M-L/XL	200 pair/cs
905	Lakeland, Tyvek®, Boot Cover, vinyl sole, elastic top	S/M-L/XL	200 pair/cs

Protective Clothing



1201

Tyvek® shirt - snap closure, long sleeve, roomy and comfortable.



802-21

Tyvek® Bouffant hat.



601

Tyvek® apron, 28" x 36", sewn ties.

850-18

Tyvek® sleeve, 18", elastic at both ends



301

Tyvek® pants - elastic waist

1104

Tyvek® lab coat, snap closure, 2 pocket, elastic wrists, long sleeve.

1101

Tyvek® lab coat, snap closure, 2 pocket, long sleeve.



Part#	Description	Size	Case Pack
1201	Lakeland, Tyvek®, Shirt, snap closure	S - XXL	50/cs
1101	Lakeland, Tyvek®, Lab Coat, snap closure, 2 pocket, long sleeve	S - XXL	30/cs
1104	Lakeland, Tyvek®, Lab Coat, snap closure, 2 pocket, elastic wrists, long sleeve	S - XXL	30/cs
601	Lakeland, Tyvek®, Apron, 28" x 36", sewn ties	OS	100/cs
850-18	Lakeland, Tyvek®, Sleeves, elastic at both ends	18"	100 pair/cs
301	Lakeland, Tyvek®, Pants, elastic waist	S - XXL	50/cs
802-21	Lakeland, Tyvek®, Bouffant hat	21" diameter	500/cs
802-24	Lakeland, Tyvek®, Bouffant hat	21" diameter	500/cs



Protective Clothing



TYCHEM® QC PERMEATION DATA

FOR ASTM RECOMMENDED LIST OF CHEMICALS FOR EVALUATING PROTECTIVE CLOTHING MATERIALS (ASTM F1001)

Chemical Name	Physical Phase	Normalized Breakthrough Times (minutes)	Permeation Rate (pg/cm ² /min)
Acetone	L	Immediate	10
Acetonitrile	L	Immediate	16
Ammonia (anhydrous)	G	Immediate	3.1
1,3-Butadiene	G	8	12
Carbon Disulfide	L	Immediate	High
Chlorine Gas	G	Immediate	> 50
Dichloromethane	L	Immediate	> 50
Diethylamine	L	Immediate	64
N,N-Dimethylformamide	L	7	0.72
Ethyl Acetate	L	Immediate	12.7
Ethylene Oxide	G	Immediate	168
n-Hexane	L	Immediate	High
Hydrogen Chloride	G	Immediate	9.3
Methanol	L	Immediate	2.2
Methyl Chloride	G	Immediate	0.3
Nitrobenzene	L	Immediate	18
Sodium Hydroxide, 50%	L	> 480	ND
Sulfuric Acid (conc.)	L	> 480	ND
Tetrachloroethylene	L	Immediate	410
Tetrahydrofuran	L	Immediate	183
Toluene	L	Immediate	High

INDEX OF CODES:

ND = none detected, > = greater than, < = less than, L = Liquid, G = Gas
Numbers reported are averages of samples tested by the ASTM F739 test method.
Sample results do vary and therefore averages for these results are reported.



5412
TYCHEM® QC COVERALL
with collar and zipper.



5414
TYCHEM® QC COVERALL, zipper, attached
hood and boots, elastic wrists.



5428
TYCHEM® QC COVERALL, zipper, attached
hood, elastic wrists and ankles.

Part#	Description	Size	Case Pack
5412	Lakeland, Tychem® QC Coverall with collar and zipper	S - 4XL	25/cs
5414	Lakeland, Tychem® QC Coverall with zipper, attached hood & boots, elastic wrists	S - 4XL	25/cs
5428	Lakeland, Tychem® QC Coverall with zipper, attached hood, elastic wrists & ankles	S - 4XL	25/cs

Protective Clothing



TYCHEM SL PERMEATION DATA

FOR ASTM RECOMMENDED LIST OF CHEMICALS FOR EVALUATING PROTECTIVE CLOTHING MATERIALS (ASTM F1001)

Chemical Name	Physical Phase	Normalized Breakthrough Times (minutes)	Permeation Rate (pg/cm ² /min)
Acetone	L	24	1.6
Acetonitrile	L	Immediate	2.8
Ammonia (anhydrous)	G	32	0.15
1,3-Butadiene	G	> 480	ND
Carbon Disulfide	L	Immediate	> 50
Chlorine Gas	G	> 480	ND
Dichloromethane	L	Immediate	> 50
Diethylamine	L	Immediate	> 50
N,N-Dimethylformamide	L	109	0.8
Ethyl Acetate	L	Immediate	6.6
Ethylene Oxide	G	Immediate	8.4
n-Hexane	L	146	0.48
Hydrogen Chloride	G	> 480	ND
Methanol	L	> 480	ND
Methyl Chloride	G	> 480	ND
Nitrobenzene	L	102	2.3
Sodium Hydroxide, 50%	L	> 480	ND
Sulfuric Acid (conc.)	L	> 480	ND
Tetrachloroethylene	L	Immediate	5.7
Tetrahydrofuran	L	Immediate	> 50
Toluene	L	Immediate	30

INDEX OF CODES:

ND = none detected, > = greater than, < = less than,

L = Liquid, G = Gas Numbers reported are averages of samples tested by the ASTM F739 test method. Sample results do vary and therefore averages for these results are reported.



44414

TYCHEM® SL COVERALL with zipper, storm flap, attached hood and boots, and with elastic wrists. Bound seam construction.



44412

TYCHEM® SL COVERALL with collar, zipper and storm flap. Bound seam construction.



44428

TYCHEM® SL COVERALL with zipper, storm flap, attached hood, elastic wrists and ankles. Bound seam construction.

Part#	Description	Size	Case Pack
44414	Lakeland, Tychem® SL Coverall with zipper, storm flap, attached hood & boot, elastic wrists	S - 4XL	12/cs
44412	Lakeland, Tychem® SL Coverall with zipper, collar, storm flap	S - 4XL	12/cs
44428	Lakeland, Tychem® SL Coverall with zipper, storm flap, attached hood, elastic wrists & ankles	S - 4XL	12/cs

Protective Clothing



HAZARD-GARD* I

Made from a nonwoven fabric with an exterior that is laminated with a 1.3 mil polyethylene film and an interior that has a comfortable, cloth-like feel against the skin. Designed with no seams in the front of the garment (the primary splash area). Available with serged or bound seams.

TYPICAL USES:

- Hazardous remediation
- Environmental clean-up
- Petrochemical/Oil refining
- Acid Handling
- Biohazard clean up



HAZARD-GARD* II

Made from a Durable, lightweight fabric with an exterior laminated with **Saranex® 23-P** film and an interior that has a comfortable, cloth-like feel against the skin. Designed with no seams in the front of the garment (the primary splash area). Available with taped or bound seams.

TYPICAL USES:

- Chemical handling/mixing/clean-up
- Hazardous material handling
- Hazardous waste clean-up
- Industrial Hazmat teams
- Petrochemical
- Utilities



KLEENGUARD®

Made from a lightweight, breathable SMS fabric that is strong and abrasion-resistant for extended wear. Offers protection against dry particulates and light liquid sprays.

TYPICAL USES:

- Maintenance/general clean-up
- Manufacturing
- Dusty environments
- Asbestos/lead abatement
- Food processing
- Laboratories
- Pharmaceuticals

NOTE: OTHER SIZES AND CONFIGURATIONS AVAILABLE

Part#	Description	Size
45573	Hazard-Gard I, Coveralls with Hood, Zipper front, elastic wrists and ankles, storm flap, serged seam, gray	L
45574	Hazard-Gard I, Coveralls with Hood, Zipper front, elastic wrists and ankles, storm flap, serged seam, gray	XL
45575	Hazard-Gard I, Coveralls with Hood, Zipper front, elastic wrists and ankles, storm flap, serged seam, gray	XXL
45576	Hazard-Gard I, Coveralls with Hood, Zipper front, elastic wrists and ankles, storm flap, serged seam, gray	XXXL
45593	Hazard-Gard I, Coveralls with Hood & Boots, Zipper front, elastic wrists and ankles, storm flap, serged seam, gray	L
45594	Hazard-Gard I, Coveralls with Hood & Boots, Zipper front, elastic wrists and ankles, storm flap, serged seam, gray	XL
45595	Hazard-Gard I, Coveralls with Hood & Boots, Zipper front, elastic wrists and ankles, storm flap, serged seam, gray	XXL
45596	Hazard-Gard I, Coveralls with Hood & Boots, Zipper front, elastic wrists and ankles, storm flap, serged seam, gray	XXXL
45654	Hazard-Gard II, Coveralls with Hood & Boots, Zipper front, elastic wrists and ankles, storm flap, bound seam, white	XL
45655	Hazard-Gard II, Coveralls with Hood & Boots, Zipper front, elastic wrists and ankles, storm flap, bound seam, white	XXL
45656	Hazard-Gard II, Coveralls with Hood & Boots, Zipper front, elastic wrists and ankles, storm flap, bound seam, white	XXXL
49003	Kleengard, Coveralls with zipper front	L
49004	Kleengard, Coveralls with zipper front	XL
49005	Kleengard, Coveralls with zipper front	XXL
49006	Kleengard, Coveralls with zipper front	XXXL
49123	Kleengard, Coveralls with zipper front, hood & boots, elastic wrists, back, and ankles	L
49124	Kleengard, Coveralls with zipper front, hood & boots, elastic wrists, back, and ankles	XL
49125	Kleengard, Coveralls with zipper front, hood & boots, elastic wrists, back, and ankles	XXL
49126	Kleengard, Coveralls with zipper front, hood & boots, elastic wrists, back, and ankles	XXXL

*TRADEMARKS OF KIMBERLY-CLARK CORPORATION

Protective Clothing



KLEENGUARD® SELECT

Made from a strong and breathable three-layer SMS fabric designed to reduce heat stress and enhance worker comfort and productivity. Offers protection against many fine dusts, fibers, and low surface tension liquid splashes (e.g., alcohols, detergents). California's Department of Pesticide Regulation, a division of state EPA, has approved KLEENGUARD® coveralls for pesticide application.

TYPICAL USES:

- Dust environments w/grinding, filing, or sanding
- Handling greases/oils
- Paint manufacturing and spraying/painting
- Machine Maintenance



KLEENGUARD® ULTRA

Made from a fabric that's tougher and more durable than previous KLEENGUARD® ULTRA Apparel fabric. The patented three-layer fabric construction of KLEENGUARD® ULTRA features a middle layer of microporous film that allows heat and sweat vapor to escape, yet protects against many dry particulates and liquids, even under pressure. It also passes ASTM F1670/1671+ testing for penetration of blood, body fluids and blood-borne pathogens.

TYPICAL USES:

- Tank cleaning
- Liquid and fiberglass handling
- Emergency medical response



REPEL®

Made from a polyethylene-coated fabric that's lightweight and resistant to many water-based liquids, greases and oils and liquid chemical splashes and sprays. Repel® coveralls pass ASTM F903 penetration testing for the wide range of liquid chemicals represented by ASTM F1001. REPEL® PASSES the ASTM F1670/1671+ testing for penetration of blood, body fluids and blood-borne pathogens. California's Department of Pesticide Regulation, a division of state EPA, has approved Repel® coveralls as chemical protection in pesticide applications.

TYPICAL USES:

- Chemical handling
- Environmental clean-up
- Oil refining
- Asbestos/lead abatement
- Tank cleaning
- Acid/caustic splash

Part#	Description	Size
58502	Kleenguard Select, Coveralls with Zipper front, elastic back, wrists and ankles, denim blue	M
58503	Kleenguard Select, Coveralls with Zipper front, elastic back, wrists and ankles, denim blue	L
58504	Kleenguard Select, Coveralls with Zipper front, elastic back, wrists and ankles, denim blue	XL
58505	Kleenguard Select, Coveralls with Zipper front, elastic back, wrists and ankles, denim blue	XXL
58506	Kleenguard Select, Coveralls with Zipper front, elastic back, wrists and ankles, denim blue	XXXL
58523	Kleenguard Select, Coveralls with Hood & Boots, Zipper front, elastic back, wrists and ankles, denim blue	L
58524	Kleenguard Select, Coveralls with Hood & Boots, Zipper front, elastic back, wrists and ankles, denim blue	XL
58525	Kleenguard Select, Coveralls with Hood & Boots, Zipper front, elastic back, wrists and ankles, denim blue	XXL
58526	Kleenguard Select, Coveralls with Hood & Boots, Zipper front, elastic back, wrists and ankles, denim blue	XXXL
45093	Kleenguard Ultra, Coveralls with Hood & Boots, Zipper front, elastic wrists and ankles, storm flap, denim blue	L
45094	Kleenguard Ultra, Coveralls with Hood & Boots, Zipper front, elastic wrists and ankles, storm flap, denim blue	XL
45095	Kleenguard Ultra, Coveralls with Hood & Boots, Zipper front, elastic wrists and ankles, storm flap, denim blue	XXL
45096	Kleenguard Ultra, Coveralls with Hood & Boots, Zipper front, elastic wrists and ankles, storm flap, denim blue	XXXL
45422	Repel, Coveralls with Zipper front, hood, elastic wrists and ankles, storm flap	M
45423	Repel, Coveralls with Zipper front, hood, elastic wrists and ankles, storm flap	L
45424	Repel, Coveralls with Zipper front, hood, elastic wrists and ankles, storm flap	XL
45425	Repel, Coveralls with Zipper front, hood, elastic wrists and ankles, storm flap	XXL

NOTE: OTHER SIZES AND CONFIGURATIONS AVAILABLE

Protective Clothing



SYSTEM CPF® RESPONDER HIGH-END HAZMAT PROTECTION

Responder® A Kappler patented limited-use fabric, **Responder®** was the first material to survive eight full hours of the ASTM F1001 Test Battery with no permeation breakthrough. Available in Level A and Level B totally encapsulating suits, coveralls, and splash hoods, with seams sewn and then taped for durability and protection. Many options are available. Applications: Emergency Hazmat Teams, Chemical Handling, Petrochemical Industry, Hazardous Materials/Waste Clean-Up. **Responder Plus®** adds tremendous strength and durability in a softer fabric along with high-visibility orange for added safety.

Part#	Description	Sizes
41550	Level A suit, Responder® , Expanded Back, Front Entry, Blue	S - XL
41570	Level B Suit, Responder® , Expanded Back, Front Entry, Blue	S - XL
41580	Hazmat Suit, Responder® , Double-Sealed, Front Entry, Blue	S - XL
43580	Hazmat Suit, Responder Plus® , Expanded Back, Front Entry, Orange	S - XL



SYSTEM CPF® CHEMICAL GARMENTS

CPF® 1 Garments provide increased physical strength and splash resistance over competing fabrics by laminating a multi-layer barrier film to a durable polypropylene substrate. Use **CPF 1®** garments in situations where protection from dry particulates and light splash is needed. Blue, with Serged or Bound seams.

CPF® 2 Garments offer greater tear resistance and chemical hold-out by laminating a layer of co-extruded barrier film to a tough 1.5 oz. polypropylene substrate. Use against a wide variety of chemicals or where rip-out is a concern. Gray, with bound or taped seams.

CPF® 3 Garments are constructed from a multi-layer barrier film laminated to a durable 2.0 oz. polypropylene substrate. They offer greater physical strength and chemical hold-out when compared to traditional film products. Use in rigorous activities and where there is potential for chemical splash. Tan, with taped seams.

CPF® 4 Garments are constructed of a multi-film composite laminated to a high strength 2.3 oz. polypropylene substrate. They offer chemical protection normally found in suits costing much more. **CPF® 4** provides one of the broadest ranges of

chemical protection available for Level B suits, eliminating the need to inventory many kinds of protective garments. Green, with strapped seams.

Part#	Description	Sizes
1B414	Coverall, CPF®1 , Hood, Zipper Front, Boots, Elastic Wrist, Bound Seam, Blue	S - 4XL
1B438	Coverall, CPF®1 , Hood, Zipper Front, Elastic Wrist and Ankles, Bound Seam, Blue	S - 4XL
1S438	Coverall, CPF®1 , Hood, Zipper Front, Elastic Wrist and Ankles, Serged Seam, Blue	M - 4XL
2B424	Coverall, CPF®2 , Zipper Front, Sock boots & Hood, Elastic Wrists, Bound Seam, Gray	S - 4XL
2B571	CPF®2 , Fully encapsulating suit, 20 mil PVC Face Shield, Expanded back, Exhaust port, Rear Zipper with Storm Flap, attached Sock Boots with Boot Flap, Bound Seam, Gray	S - 4XL
2T424	Coverall, CPF®2 , Zipper Front, Sock Boots & Hood, Elastic Wrists, Taped Seam, Gray	S - 4XL
3T414	Coverall, CPF®3 , Zipper Front, Hood & Boots, Elastic Wrist, Taped Seam, Tan	S - 5XL
3T424	Coverall, CPF®3 , Zipper Front, Hood & Sock Boots, Elastic Wrist, Taped Seam, Tan	S - 4XL
4T424	Coverall, CPF®4 , Zipper Front, Hood & Sock Boots, Elastic Wrists, Taped Seam, Green	M - 4XL
4T571	CPF®4 , Fully encapsulating suit, 20 mil PVC Face Shield, Expanded back, Exhaust port, Rear Zipper with Storm Flap, attached Sock Boots with Boot Flap, Taped Seams, Green	S - 3XL

Protective Clothing

INTERNATIONAL
ENVIROGUARD
SYSTEMS, INC.



#2119

**PE COATED
POLYPROPYLENE...
FOR CERTAIN SPLASH
PROTECTION**

Part#	Description	Sizes	Case Pack
2119	PE Coated Coveralls, Elastic Wrist, with Hood & Boot	L - XXXL	25/cs
2112	PE Coated, Standard Coverall, open Ankle, Elastic Wrist	L - XXXL	25/cs
5500W	PE Coated Sleeve, White	18"	500/cs
5500B	PE Coated Sleeve, Blue	18"	500/cs

**NON-WOVEN
POLYPROPYLENE
BOUFFANT CAPS & BEARD RESTRAINTS**



#110NW-21

#112NW

Part#	Description	Case Pack
110NW-19	19" Bouffant Cap, White*	1000/cs
110NW-21	21" Bouffant Cap, White*	1000/cs
110NW-24	24" Bouffant Cap, White*	1000/cs
110NW-19B	19" Bouffant Cap, Blue*	1000/cs
110NW-21B	21" Bouffant Cap, Blue*	1000/cs
110NW-24B	24" Bouffant Cap, Blue*	1000/cs
112NW	Beard Restraints**	1000/cs

* Available to order in Green, Yellow, and Pink.
Bouffant Caps packed 100 each to a poly-dispenser bag.
** Beard Restraints packed 100 each per bag. Blue available to order.

**POLYETHYLENE
PRODUCTS**



#110NW-24

#PE1016

#PE102846IB



LATEX BOOTS

#2513Y

Part#	Description	Case Pack
PE102442	1.0 Mil White Embossed 24"x 42" PE Apron	100/bag 10 bags/cs
PE102846	1.0 Mil White Embossed 28"x46" PE Apron	100/bag 10 bags/cs
PE102442IB	1.0 Mil White Embossed 24"x42" PE Apron, individually bagged	100/bag 10 bags/cs
PE102846IB	1.0 Mil White Embossed 28"x46" PE Apron, individually bagged	100/bag 10 bags/cs
PE1016	1.0 Mil White Smooth, 16" Sleeve*	1000 ea/cs
PE18L	1.0 Mil Clear Embossed Gloves, Lg.	10,000/cs, 50/bx, 20 bx/cs
2513Y-XL	Yellow Latex Nuke Boots	50 pr/cs
2513Y-XXL	Yellow Latex Nuke Boots	50 pr/cs

* Packed 100/bag, 100 bags/case

Protective Clothing



#1361

INTERNATIONAL
ENVIROGUARD
 SYSTEMS, INC.

SPUNBONDED POLYPROPYLENE



#2012



#4000W



#N2019



#3100-3

Part#	Description	Sizes	Case Pack
2019	Coverall with attached hood and boots, Elastic Wrists, White	XL - XXXL	25/cs
LB2019	Coverall with attached hood and boots, Elastic Wrists, Light Blue	XL - XXXL	25/cs
N2019	Coverall with attached hood and boots, Elastic Wrists, Navy Blue	XL - XXXL	25/cs
2012	Standard Coveralls, Elastic Wrists and Open Ankles, White	S - XXXL	25/cs
5501	Polypropylene Sleeves, White	18"	500 ea/cs
1361	Briefs, White	OS	100/cs
4000W	Poultry Smock, White	OS	50/cs
3100-3	Anti-Skid Shoe Cover with Elastic Top and Bottom	M - XL	300 ea/cs

Protective Clothing



INTERNATIONAL
ENVIROGUARD
SYSTEMS, INC.

DURAGUARD... WHEN A HEAVIER DUTY PE COATING IS NEEDED



#6025

TECHNICAL DATA SHEET		
DURAGUARD		
PHYSICAL PROPERTY	TEST METHOD	DURAGUARD
Basis Weight	ASTM D751	1.7 oz./sq. yd.
Grab Tensile Strength (lbf)	ASTM D751	M 21.4 lbs. C 15.4lbs.
Puncture/Propagation Tear	ASTM D2582	M 5.7 lbs. C 6.9 lbs.
Ball Burst Strength (lbf)	ASTM D3787	22.6 lbs.
Hydrostatic Water Resistance (column height in.)	ASTM D571	68"

Part#	Description	Sizes	Case Pack
6019	Coverall with attached Hood and Boot, Elastic Wrist, White*	XL - XXXL	25/cs
6012	Standard Coverall, Elastic Wrist, Open Ankle, White*	XL - XXXL	25/cs
6025	White Lab Coat, No pocket	L - XXXL	25/cs
6100	White Shoe Cover	N/A	300 ea/cs
6500	White Sleeves, 18"***	N/A	200 ea/cs
6102-55	Apron, 35" x 55", White	N/A	100/cs

* COVERALLS ARE ALSO AVAILABLE IN BLUE AND YELLOW

** SLEEVES ARE AVAILABLE TO ORDER IN 24" LENGTH

DURAGUARD FABRIC CHEMICAL RESISTANCE

Duraguard fabric has been tested for liquid chemical penetration using ASTM F903-96, *Standard Test Method for Resistance of Materials Used in Protective Clothing to Penetration to Liquids*. Depending on chemical concentrations, exposure potential or use conditions, a higher level of protection may be required. **These test results should not be used as the only basis for protection recommendations.** Ask for a copy of the Results.

The ASTM F903-96 test procedures require testing for 5 minutes at no pressure, 1 minute at 2 psi and 54 minutes at no pressure. Pass or Fail is recorded after visual observation of the test material. Ask for a copy of the Results.

LIQUID PESTICIDE RESISTANCE OF FABRIC

International Enviroguard has independently tested the Duraguard fabric for barrier protection from some of the more common and popular agricultural pesticides.

The test methodology was BS EN 368-193 *Resistance of Materials to Penetration by liquids, modified, "Syringe Method."* A stream of test liquid of designated concentration was directed at the fabrics. The "Repellency %" was the amount of test liquid that neither penetrated nor was absorbed by the fabric. This test method was designed to simulate exposure to aerosol overspray and residual chemical exposure during spray operations. Ask for a copy of the Results.

Protective Clothing

INTERNATIONAL
ENVIROGUARD
 SYSTEMS, INC.



#CA6RE



#ARE655

VINYL PRODUCTS

#BSL618

BLUE SLEEVES

Part#	Description	Case Pack
BSL418	4 Mil Blue Vinyl, 18" Sleeve	12 dz/pr-cs
BSL618	6 Mil Blue Vinyl, 18" Sleeve	12 dz/pr-cs
BSL818	8 Mil Blue Vinyl, 18" Sleeve	12 dz/pr-cs

WHITE AND CLEAR AVAILABLE

BLUE APRONS: RAW EDGE, SHOE STRING TIES

Part#	Description	Case Pack
ARE648	6 Mil 35" x 48" Raw Edge Apron	6 dz/cs
ARE650	6 Mil 35" x 50" Raw Edge Apron	6 dz/cs
ARE655	6 Mil 35" x 55" Raw Edge Apron	6 dz/cs
ARE850	8 Mil 35" x 50" Raw Edge Apron	6 dz/cs
ARE855	8 Mil 35" x 55" Raw Edge Apron	6 dz/cs

BLUE APRONS: HEMMED EDGE, SHOE STRING TIES

Part#	Description	Case Pack
AH645	6 Mil 35" x 45" Hemmed Apron	6 dz/cs
AH648	6 Mil 35" x 48" Hemmed Apron	6 dz/cs
AH650	6 Mil 35" x 50" Hemmed Apron	6 dz/cs
AH655	6 Mil 35" x 55" Hemmed Apron	6 dz/cs
AH848	8 Mil 35" x 48" Hemmed Apron	6 dz/cs
AH850	8 Mil 35" x 50" Hemmed Apron	6 dz/cs
AH855	8 Mil 35" x 55" Hemmed Apron	6 dz/cs

BLUE DIE CUT APRONS

Part#	Description	Case Pack
ADC645	6 Mil Die Cut 35" x 45"	6 dz/cs
ADC648	6 Mil Die Cut 35" x 48"	6 dz/cs
ADC650	6 Mil Die Cut 35" x 50"	6 dz/cs
ADC655	6 Mil Die Cut 35" x 55"	6 dz/cs

BLUE COAT APRONS: SHOE STRING TIES

Part#	Description	Case Pack
CA6RE	6 Mil Coat Apron	3 dz/cs

**ALL VINYL PRODUCTS ARE AVAILABLE TO ORDER IN OTHER MIL THICKNESSES
 AND ARE AVAILABLE IN CLEAR OR WHITE**

Protective Clothing



.35mm

CLASSIC

The Classic is available in 2 and 3 piece suits; jacket, detachable or attached hood and bib pants.

- Soft Fabric with long term durability
- Well suited for wide variety of job applications

Part #	Description	Sizes
200C	Raincoat 49", 2 pockets, detachable hood, with cape vented back, yellow	S - 4XL
201C	Raincoat 49", 2 pockets, detachable hood with cape vented back, fluorescent orange	S - 4XL
260C	Raincoat 60", 2 inner leg snaps, corduroy collar with snaps, detachable hood, yellow	S - 4XL
267C	Raincoat 60", 2 inner leg snaps, corduroy collar with snaps, detachable hood, black	S - 4XL
2002	2 Piece suit; jacket with attached hood and bib pants, yellow	S - 4XL
2003	3 Piece suit; jacket, detachable hood, and bib pants, yellow	S - 4XL
2013	3 Piece suit; jacket, detachable hood, and bib pants, fluorescent orange	S - 4XL
2303	.30mm PVC/Polyester; 3 Piece suit; jacket, detachable hood, and bib pants, yellow	S - 4XL

LUMINATOR

When visibility is top priority. Great for airlines, police, road crews and sanitation workers.

- 2" 3M™ Scotchlite™ reflective striping for high visibility in silver/lime or orange/silver
- Bright safety orange and yellow colors
- Bib pants
- Available in three types of material
~ .35mm PVC/Polyester



Other suits in the **Luminator** series come in:
.28mm PVC/Nylon/PVC
or
.16mm PVC/Nylon

Part #	Description	Sizes
201CR	Raincoat 49", with cape vented back, 2 pockets, detachable hood, fluorescent orange with silver/lime stripes	S - 3XL
2013R	3 piece suit, jacket with patch pockets, bib pants, detachable hood, fluorescent orange with silver/lime stripes around chest, waist & arms of jacket and around both legs at knee on the bib pants, .35mm PVC/Polyester	S - 3XL
2083R	3 piece suit, jacket with flap pockets, bib pants, detachable hood, lime with orange/silver stripes around arms & body of jacket & across shoulders also on both legs at knee on the bib pants, .35mm PVC/Polyester	S - 3XL

CONCORD

The Concord series is great for the mining industry, petroleum related industries, logging and ship building organizations.

- Premium quality neoprene with a single coat over nylon fabric base.
- Flame retardant.
- Double stitched and taped seams.
- Quick release suspenders.
- Offers excellent resistance to most chemicals, oils, and acids.

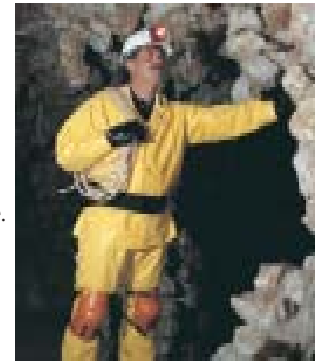

.35mm neoprene/nylon

Part #	Description	Sizes
800JH	Jacket with attached hood and snap storm fly front, yellow	S - 4XL
800CN	Raincoat 49", no hood, snaps for hood attachment, yellow	S - 4XL
800BP	Bib pants, snap fly front, full elastic suspenders and take up snaps at waist and ankles, yellow	S - 4XL



"Made Tough for Tough Jobs"

DOMINATOR

The Dominator 3882 complete 2 piece suit; jacket with attached hood, inner sleeve and bib pants. This series has a tough nylon scrim material double coated with 2 thick layers of PVC for a combined thickness of **.42mm**.

Wide range of uses including:

- Chemical plants
 - Refineries
 - Environmental cleanups
- WITH ADDED FEATURES:
- Offers best protection against many chemicals and acids
 - Flame retardant



Part #	Description	Sizes
3881	One piece coverall, zipper front, double storm flap, attached hood, green*	S-4XL
3882	Complete suit 3pc, jacket with attached hood, inner sleeve, and bib pants, green	S-4XL
3981	One piece coverall, zipper front, double storm flap, attached hood, inner pant cuffs, green*	S-4XL

*10" x 10" reinforced crotch and inner sleeves with elastic wrist closure, hood has a draw string.

**SOME STYLES
HAVE OTHER COMBINATIONS OR PIECES AVAILABLE.
ASK FOR MORE INFO!**



Foot Protection

STANDARD

This boot has Moderate Chemical Protection, along with a Steel safety toe in selected styles for maximum protection.



Women's sizes and styles available.



Cut off bands for height adjustment.

Pull-up and kick off lugs.

Steel shank for safety (available only in men's styles)

APOLLO
This boot is comfortable, fashionable and has waterproof protection all for a very reasonable price.

New Product

Cut-off band that contours to the leg to reduce chaffing.



Built-in arch support for all-day comfort.

Kick-off lug for easy removal.



Ribbed sole pattern that "grips" wet surfaces

Extended steel shank to provide heel and instep support.

Part #	Description	Sizes
86312	Standard Mens, Steel toe, 16"	6 - 13
86206	Apollo, Plain toe	6 - 13
86207	Apollo, Steel toe	6 - 13

IF WHAT YOU ARE LOOKING FOR IS NOT LISTED, ASK OUR EXPERIENCED SALES PERSONNEL. THEY WILL BE GLAD TO ASSIST YOU IN FINDING THE ITEM YOU NEED TO DO THE JOB SAFELY!

STEEL TOE meets or exceeds: ANSI STD Z41 PT 91 I/75 C/75 for impact and compression, as well as CSA STD Z195 M92 Grade 1.

POLYMAX®

Proven protection for red meat processing. Constructed of high molecular weight resins.

ULTRAGRIP®Sipe sole Ergonomically designed for durability and slip resistance.

Pull-up and kick off lugs.

#84076



Toe & heel Bumpers

WHITE PVC

For protection in the fishing and shrimping industries.

#81012



Cut off bands for height adjustment.

Kick off lugs

SAFETY -LOC SOLE
Designed for superior traction on wet or slippery surfaces.

HAZMAX®

This series is the finest boot made for hazardous materials handling.

ULTRAGRIP®Sipe sole Ergonomically designed for durability and slip resistance.

#87012



Replaceable cushioned insoles

Pull-up and kickoff lugs.

Part #	Description	Sizes
84076	Polymax, Steel toe, 16"	7 - 13
81012	White PVC, Steel toe 16"	6 - 13
87012	Hazmax, Steel toe, full steel mid sole, 16"	7 - 13

AIR CUSHION INSOLE



The Air Cushion insole features a polyurethane foam layer that prevents odor. Its perforated design ensures breathability.

Part#	Description	Sizes
90235	Air Cushion Insole	6-14

RESISTOR



This Boot is made with a high-level urethane content with special vinyl resin for high abrasive wear. Steel shank for firm arch support in men's styles and net lined for easy on and off use. Safety toe meets or exceeds ANSI F I/75 C/75 - ANSI M I/75 C/75 specifications. Superior resistance to animal fats (especially red meats), acids, oils, greases and chemicals. This Boot is good for use in Meat & Food Processing/Dairy, Refining, Heavy Manufacturing & Processing, General Industrial/Safety, General Outdoor, Construction/Contracting.

Part #	Description	Sizes
89782	Resistor, Mens	7-13



MONARCH

These boots are made from high molecular weight PVC compound. The steel toe and steel midsole models meet or exceed ANSI specifications. Model #87568 offers CSA Grade 1 toe protection with optional sole protection. They are net lined for easy on and off and have a molded-in insole. The bar cleat outsole is designed for traction. They are excellent in wet, muddy conditions where chemical resistance is not a priority. They offer high abrasive wear. The steel shank provides firm support. They are excellent for Meat & Food Processing/Dairy, Refining, Heavy Manufacturing & Processing, Water & Sewer Utilities/Power Transmission, Commercial Fishing & Processing, Construction/Contracting, General Industrial/Safety, General Outdoor.



Part #	Description	Sizes
87516	Boot, Mens, 16", Steel Toe	6-13
87568	Boot, Mens, 16", Steel Midsole, CSA Safety Toe	6-13

MONARCH VINYL CHEST WADER



This chest wader is made from a high molecular weight PVC compound. The steel toe model #87152 meets or exceeds ANSI specifications and CSA Grade 1 toe protection. It is net lined for easy on and off and has a molded-in insole. The bar cleat outsole is designed for traction. It is excellent in wet, muddy conditions where chemical resistance is not a priority. It offers high abrasive wear and a steel shank for firm support. Excellent for General Industrial/Safety, Construction/Contracting, Commercial Fishing & Processing, Water & Sewer Utilities/Power Transmission, Refining, Heavy Manufacturing & Processing.

Part #	Description	Sizes
87152	Chest Wader, Mens, Steel Toe	6-14



Foot Protection

BOSS® MANUFACTURING COMPANY



OVER-THE-SHOE RUBBER BOOT

Men's heavy duty hand-piled yellow rubber leggin' boot, 17" tall, fabric lining, top strap and buckle, bar-tread outsole. These mucking boots are used in the construction industry when working with concrete.

Part#	Description	Boot Size
2KP44817	Over-the-shoe Rubber Boot	7
2KP44818	Over-the-shoe Rubber Boot	8
2KP44819	Over-the-shoe Rubber Boot	9
2KP448110	Over-the-shoe Rubber Boot	10
2KP448111	Over-the-shoe Rubber Boot	11
2KP448112	Over-the-shoe Rubber Boot	12
2KP448113	Over-the-shoe Rubber Boot	13
2KP448114	Over-the-shoe Rubber Boot	14
2KP448115	Over-the-shoe Rubber Boot	15



LAM-IN-SOLE SAFETY INSOLES

Lam-In-Sole Safety Insoles slip into boots, work shoes, dress shoes, even jogging shoes, and they're so comfortable you'll forget you're wearing them. To make this safety insole they start with one piece of .020" rustproof, flexible, stainless steel for complete toe to heel protection. Then they add a 1/8" thick foam latex pad for comfort. They are only 3 ounces each.

You'll feel like you're walking on air. Lam-In-Soles make boots, especially, much more comfortable to walk or work in. Indispensable to firefighters, farmers, carpenters, construction workers, miners, hunters, industrial workers, policemen, joggers, architects - people in all walks of life who risk puncture injuries or bone bruises. Work shoe sizes from 6 to 15, rubber boot sizes from 4 to 13.



Part#	Description	Shoe Size	Boot Size
I-6	Insole, AA, Work	6	4
I-7	Insole, A, Work	7	5
I-8	Insole, B, Work	8	6
I-9	Insole, C, Work	9	7
I-10	Insole, D, Work	10	8
I-11	Insole, E, Work	11	9
I-12	Insole, F, Work	12	10
I-13	Insole, G, Work	13	11
I-14	Insole, H, Work	14	12
I-15	Insole, I, Work	15	13

SANKEY FOOT GUARDS



Ellwood Safety's Sankey Foot Guards are metal shields worn over shoes for maximum protection to the entire foot-instep as well as toes-against falling, rolling, or flying objects or accidental tool blows. They are designed to

withstand an impact of 75 foot pounds, with a large safety factor built in. Foot guards fit any shoe (no rights or lefts), with 5" (average) and 5 1/2" (large) widths. They are light enough to be worn comfortably all day. To keep the guard properly positioned, it has a rubber toe clip, crossbar, and either a two-piece leather strap with a spring fastening device or a one-piece rubber strap with a tension buckle.

Part#	Description	Size
2005	Foot Guard, Aluminum Alloy	5
20055	Foot Guard, Aluminum Alloy	5 1/2
2006	Foot Guard, Aluminum Alloy	6

*Size of Foot Guards are based on width of foot.

TOE GUARDS



These Toe Guards fit any shoe and provide maximum toe protection with no discomfort because they don't encase the toe. Abnormal foot conditions do not cause problems. Weighing just 12 ounces, each guard is designed to withstand an im-

impact of 75 foot pounds with a large safety factor built in. Width 4 1/2" men, 4" women. The 700 model adds a leather cuff behind the carbon steel toe.

Part#	Description	Size
700T	Toe Guard, Steel, Leather Cuff, Quick Fastener, Adjustable WebStrap	OS
702TG	Toe Guard, Steel, Quick Fastener, Adjustable Web Strap	OS

ELLWOOD SAFETY
Appliance Company

FULL BODY HARNESSSES



Every DBI/SALA harness combines maximum comfort, freedom of movement and ease of use—without sacrificing safety. All harnesses are designed to securely retain you in case of a fall and distribute the impact forces throughout your thighs, buttocks, chest and shoulders.

Our exclusive Delta No-Tangle™ pad holds the shape of the harness, adding to your comfort, and making it easier to put on. This added comfort and ease of donning has greatly increased worker acceptance and reduced the possibility of improper usage.

Because they are constructed from polyester webbing, our harnesses offer better resistance to sunlight and chemical degradation than those made of other materials. With many different styles and various D-ring, leg strap and buckle options, there is always a model available to meet your specific needs.

DBI/SALA harnesses were developed and engineered in full compliance with applicable industry standards including OSHA, ANSI Z359-1992, ANSI A10.14-1991, and CSA Z259.10-M90 regulations.

* Product numbers followed by an * do not meet CSA Standards

Sized to Fit! More grommets, more webbing, plus our unique five-point adjustment. For a truly customized fit, no one else comes close.

Designed for a Long Life!

Polyester webbing resists abrasion and UV and chemical degradation.

A Stitch in Time!

Compare our stitching and precise stitch patterns to anyone else; we sew in strength you can trust.

Neat as a Pin!

Web keepers at all adjustment points hold extra webbing so it is tucked away and out of your way.

You'll Say Thank You!

Our seat slings provide both comfort and even distribution of fall arrest forces. We design the best.



Securely Fastened! Non-slip chest strap moves when you want it to; stays put when it should. Metal pass-thru buckle delivers added strength and safety.

No More Aching Back!

Built-in loops for a body belt allow you to customize the harness with your own belt and the harness will support it. Add tools and pouches—enjoy the back support.

Precision Power!

Cadmium-plated forged alloy steel hardware precisely engineered for maximum strength, durability and reliability. 5000 lbs. tensile strength.

It's in the Book!
All product and inspection information right at your fingertips with our book-style labels.



A Perfect Fit for every body

Whether you wear a harness 4 hours a day or 14 hours a day, it needs to feel good and fit right for optimum comfort, safety and productivity. DBI/SALA harnesses are designed to fit you—no matter what your size or shape!

Primary Applications:

Fall Arrest = FA
Work Positioning = WP
Restraint = RT
Rescue = RC

Patent Pending Delta-No Tangle™ Pad

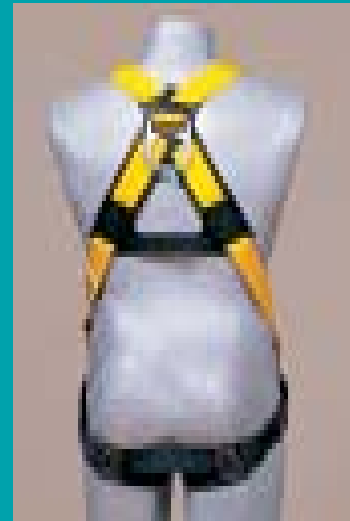

The Delta Pad makes every harness easy to don and comfortable to wear, with the widest spread over your shoulders in the industry. No more irritating shoulder strap abrasion!

Fall Protection



Vest Style Full Body Harness

With adjustable non-slip chest straps designed for comfort and stability.

110200

- Tongue buckle leg straps
- Back D-ring
- Parachute buckles on lower shoulder straps
- Size: Universal
- Application: FA, RT

Similar Model:

1106201: Reflective



110208

- Tongue buckle leg straps
- Back and side D-rings
- Parachute buckles on lower shoulder straps
- Size: Universal
- Application: FA, RT, WP

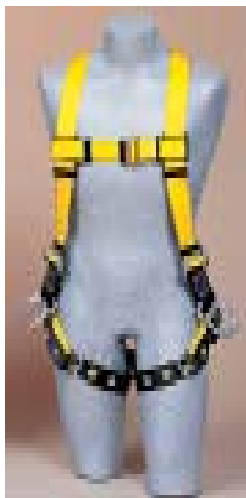

110201

- Parachute buckle leg straps
- Back D-ring
- Size: Universal
- Application: FA, RT

Similar Model:

1101828: with shoulder retrieval D-rings



110209

- Parachute buckle leg straps
- Back and side D-rings
- Size: Universal
- Application: FA, RT, WP

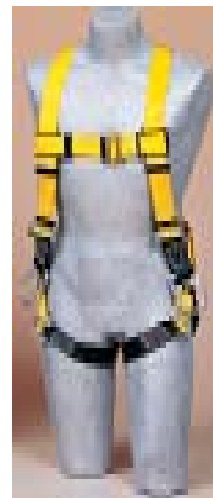

Construction Vest Style Full Body Harness

1101655

- Tongue buckle leg straps
- Back D-ring
- Body belt with side D-rings
- Sewn-in back pad
- Sewn-in shoulder pads
- Sizes: Large (SM-3XL avail.)
- Application: FA, WP, RT

Similar Models:

1101654: medium

1101656: x-large



Dorsal Web Loop Full Body Harness

Excellent choice for utility workers.

1104730 *

- Use with web loop lan-yards for ultimate safety
- Reduced weight and electrical conductivity
- Vest-style
- Pass-thru buckle leg straps
- Non-conductive/non-sparking PVC coated hardware

Back view of 1104730

- Dorsal web loop (replaces back D-ring)
- Size: Universal
- Application: FA, RT

Similar Model:

1101259: standard hardware and tongue buckle leg straps

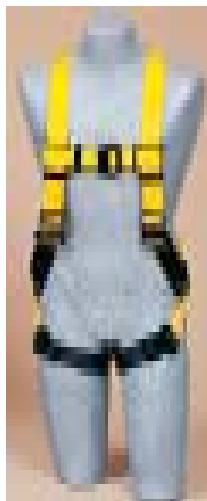



Workseats

Whether the job is window washing, maintenance, painting or other suspended work applications, **DBI/SALA has a suspension support style and model already designed for the task.** Design options include leg straps, board seat, cushion, D-rings, buckles and more. All models feature 1-3/4 inch wide latex treated polyester webbing (8,800 min. tensile strength) and drop forged cadmium plated alloy steel hardware (5,000 lb.min. tensile strength). Some models also feature a 3-inch wide seat sling and most offer a body belt with 3-inch pad for back support.



Boatswain's Chairs



1001134

- Seat board (12"x24"x1")
- Tongue buckle belt w/back D-ring
- Wear pads at contact areas
- Size: Large

Similar Model:

1001140: without belt

Suspension Workseat



1001004

- Seat board
- Tongue buckle body belt with 3" pad
- Back D-ring
- Suspension D-rings
- Adjustable leg and shoulder straps
- Size: Large

1001190

- Seat board (12"x24"x1")
- Cushion
- Wear pads at contact areas
- Side snaps to hang equipment or tools

Similar Models:

1001170: with cushion only

1001180: with side snaps only



Seat Sling

1001090

- Designed for attachment to a full body harness for extra support
- 8" wide seat sling
- Belt attachment loops and D-rings

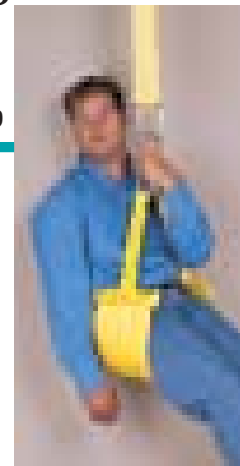

Note: Federal law requires the use of a separate harness and lifeline with suspension supports. (Reference OSHA standards.) To comply with federal law, the full body harness must include a back D-ring for connection with an independent lifeline and must incorporate a fall arrest sub-system that will limit the maximum free fall to six feet or less and limit the maximum arresting force to 1,800 lbs. or less.





Lanyards

With a relentless dedication to quality and safety, DBI/SALA has designed and manufactured fall arrest, positioning and restraint lanyards for over 25 years. We carefully engineer every lanyard with your safety as our primary objective, focusing on quality design, components and manufacture. We want you out there on the job with **complete peace of mind!**

DBI/SALA shock absorbing lanyards meet or exceed all applicable industry standards, including OSHA, ANSI A10.14-1991, ANSI Z359.1-1992, and CSA Z259.1-1976, CSA Z259.11-M92 .

* Product numbers followed by an * do not meet CSA Standards

Super strength. Polyester webbing with tensile strength from 5,750 to 9800 lbs. won't give out, even when you do.

Many configurations and combinations. We have shock absorbing lanyards for every industry, every application.

Always under 900 lbs. As vital components of a complete fall arrest system, shock absorbing lanyards limit arresting forces to no more than 900 lbs.

Stitched for toughness. At 5 to 7 stitches per inch, lanyards are sewn tough for rough action.



ShockWave2™

ShockWave2™ lanyards are stretchable for complete freedom of movement. They expand to 6 ft. and contract to 4-1/2 ft. in reaction to your movements, **reducing trip fall hazards, dragging and snagging.** In case of a fall, the unique inner core immediately begins to extend and absorb energy, limiting arresting forces to 900 lbs. or less.



1224306 *

- Expands to 6 ft. and contracts to 4-1/2 ft.
- Abrasion resistant tubular webbing
- Self-locking snap hooks at ends
- Impact indicator

Similar Models:

1224311: with 2007153 aluminum hook (2-1/4" opening) at one end

1224321: with 9510057 flat steel hook (2-1/4" opening) at one end

1224409 *

- Expands to 6 ft. and contracts to 4-1/2 ft.
- Twin-leg 100% tie-off type
- Self-locking snap hook at center, aluminum hooks (2-1/4" opening) at leg ends
- Impact indicator

Similar Models:

1224406: with self-locking snap hooks at all ends

1224412: with 9510057 flat steel hooks (2-1/4" opening)

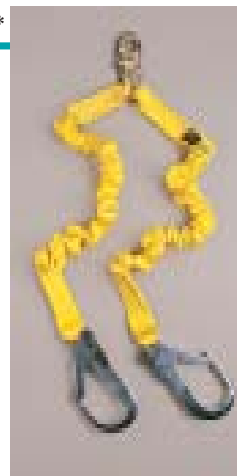

Tested by the pros. All DBI/SALA lanyard hardware is proof tested to meet or exceed industry standards.



Easy connections, even with gloves on! Our patented, user friendly self-locking snap hooks open and connect without thumbs or fingers getting in the way. They're industry-preferred!



Lanyards



EZ Stop® II (Soft Cover)

EZ Stop® II shock absorbing lanyards are designed for **versatility and are available in many variations**. There is certain to be a model that will meet your requirements from this popular product line. All EZ Stop® II lanyards utilize a tearing action when subjected to fall arrest forces, keeping the arresting forces under 900 lbs.

1220006

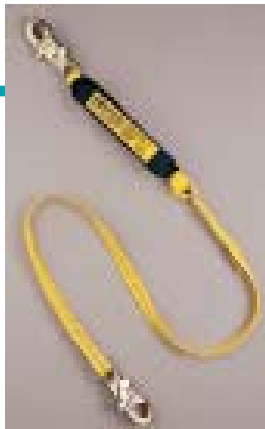

- 1" polyester web
- Self-locking snap hooks at ends
- 6 ft. long

Similar Model:

1220256: adjustable in length

1220077: with aluminum hook

(2-1/4" opening) at one end

1220007: 3 ft. long

1220416



- 1" polyester web
- Twin-leg 100% tie-off type
- Self-locking snap hook at center, 2007153 aluminum hooks (2-1/4" opening) at leg ends
- 6 ft. long

Similar Model:

1220406: with self-locking snap hooks at all ends

EZ Stop® II Tie-Back Lanyards

Use these EZ Stop® II lanyards to **eliminate the need for a separate anchorage connector** (ex: tie-off adapter). The 100% tie-off two-legged lanyards allow you to keep one leg attached to the anchorage while the other leg is always ready to be hooked to the next anchorage.

1221106



- 1" polyester web with abrasion resistant tubular wear layer webbing
- Self-locking snap hooks at both ends
- Floating D-ring (lanyard can be choked off)
- 6 ft. long

Similar Model:

1221206: with 100% tie-off twin leg configuration



Rebar and Wall-Form Hook

Assemblies

Use these positioning and restraint lanyards while performing such tasks as rebar tying or construction of wall-forms. DBI/SALA's **unique hooks provide a safe and compatible connection to many types of structures**. Like all positioning and restraint lanyards, they should only be used in applications that limit the free fall to two feet or less.



5900051

Chain Rebar Assembly

- Twist link chain rebar lanyard
- Self-locking snap hooks on leg ends
- Swiveling 2007153 (2-1/4" gate opening) alum. hook at center
- 22" long

Similar Models:

5900080: without swivel, 20.5" long

5900050: with flat steel hook (2-1/4" opening)

1201520: with web instead of chain

Rope Grabs & Lifelines

Suspended Platform Work

DBI/SALA has you covered with a complete line of mobile and static rope grabs for both synthetic fiber rope and steel wire cable, along with a wide variety of lifelines to meet your work needs. All of our rope grabs are made of high grade corrosion resistant materials. **Our most popular LAD-SAF® rope grabs automatically follow you, giving you maximum freedom and hands-free operation.** They can be detached or removed anywhere along the lifeline. The rope grabs utilize a cam lever as well as a friction sensitive brake to lock the rope grab onto the lifeline in case of a fall, even if the operator holds the device open in a panic situation. They will also reduce the arresting forces on a worker if there is a fall. We manufacture a complete range of lifelines for use with our rope grabs. They are available in 5/8 inch or 3/4-inch polyester or polyester/polypropylene blend rope and in cut lengths or assemblies that include a self-locking snap hook at one end.

DBI/SALA offers several styles of counterweights to keep the lifeline taut and optimize performance of the rope grab.



5003050 LAD-SAF® Rope Grab System

- 5/8" dia. rope grab (5001441)
- 50 ft. lifeline (1202794)
- Flexible counterweight, 5.7 lbs. (5901583)
- 3 ft. EZ Stop® II shock absorbing lanyard (1220007)
- 3 ft. tie-off adapter (1002000)
- Carry bag (9511597)

Similar Model:
5003100: with 100'
lifeline

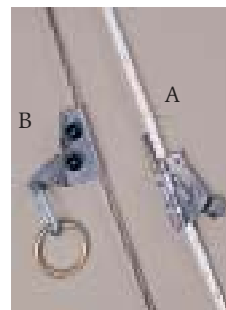

A. 5001441 LAD-SAF® Mobile Rope Grab

- Inertia/cam locking system
- Energy (shock) absorbing design
- Detachable
- Fits 5/8" dia. rope lifeline
- Corrosion resistant aluminum and stainless steel construction

Similar Model:
5001442: fits 3/4" dia. rope
lifeline

B. 5000338 LAD-SAF® Static Wire Rope Grab

- Patented wedging action grips and locks onto cable lifeline
 - Attachment ring for connecting to lanyard
 - Fits 3/8" dia. 7x19 galvanized or stainless steel cable
 - Detachable
 - Stainless steel construction
- IMPORTANT: Max. Lanyard Robe Grab Length**
5001441 3 ft.
5001442 3 ft.
5000338 4 ft.



1202754 Lifeline Assemblies

- 5/8" polyester/polypropylene blend rope
- Self-locking snap hook at one end
- Taped at other end
- 30 ft. long

Similar Models:
1202794: 50'
1202821: 75'
1202844: 100'



1220007

- 3 ft. EZ Stop® II shock absorbing lanyard





Don't let cheap imitations not meeting ANSI Z359 leave you hanging. Basix Gear is engineered for work, guaranteed to last through your toughest job and then some. Not only do workers deserve equipment that's tough and durable, they will appreciate exceptional comfort performance and fit Basix offers. Basix bring you the finest in craftsmanship and materials and the latest in fall protection technology. No matter who you are or what you do, DBI/Sala has the gear for you to get through the day safely.



1310000

Back D-ring, color coded straps, tongue buckle legs, loops for tool belt. Universal sized.



1330010

6 ft. shock absorbing lanyard with standard double locking snap hooks. Brings worker to a safe comfortable stop.



1350000

Chain rebar assembly with large gate opening hook.

**GUARANTEED QUALITY AND COMFORT * FULL OSHA/ANSI COMPLIANCE
INCLUDING ANSI Z359 * COMPLETE USER ACCEPTANCE**

Self Retracting Lifelines

DBI/SALA was the first in the industry to develop self retracting lifelines (SRL's) and they are still the most popular products of their kind available anywhere! **SRL's extend and retract automatically, letting you comfortably move about** at your normal speed within a recommended working area, while operating at peak efficiency. From the light-weight 8 ft. Talon™ to our 175 ft. SRL, DBI/SALA always has a model for your specific job.

Every DBI/SALA SRL meets or exceeds all applicable industry standards, including OSHA, ANSI A10.14-1991, ANSI Z359.1-1992 and CSA requirements .

Built to last. Stainless steel working components offer ultimate corrosion resistance, reliability and longevity. Backed by the best warranty and servicing in the industry.

Locked for good. For complete safety, our SRLs have built-in anti-ratcheting capabilities. Once they lock, they stay locked.

Like King Tut's tomb. It takes more than bolts to seal an SRL tightly. No one does it better than us. Using sealed gaskets, we completely separate the working components in their own environmentally sealed chamber.

A quick look for safety. View the impact indicator, located on the snap hook (for quick and easy inspection), to see if the unit has been impact loaded.

Lightest in the industry. For ease of use and worker acceptance, our SRLs are the **LIGHTEST** in the industry (no matter what others may claim)!



Sealed SRL's

These SRL's incorporate a **revolutionary patented concept that separates all dynamic components**, including the motor spring and brake, **from foreign elements** such as grease, moisture and dirt. You always know your SRL is operating at peak efficiency, without worries about what is happening inside the housing, no matter how dirty or damp your environment!



3403400

- Corrosion-resistant cast aluminum/stainless steel housing
- Self-adjusting disc brake
- Reserve lifeline retention system
- 3/16" galvanized steel wire rope (stainless avail.)
- Self-locking swivel snap hook with impact indicator
- 50 ft. long
- Weight = 12 lbs.

Similar Models:

3403401: 50 ft. stainless steel

3403500: 85 ft. galvanized

3403501: 85 ft. stainless steel

3403600: 130 ft. galvanized

3403601: 130 ft. stainless steel non-sealed:

3400610: 175 ft. galvanized

3400611: 175 ft. stainless steel



3403402

- Includes all features of 3403400
- Built-in retrieval winch for raising/lowering load during emergencies
- Weight = 36 lbs.

Similar Models:

3403403: 50 ft. stainless steel

3403502: 85 ft. galvanized

3403503: 85 ft. stainless steel

3403602: 130 ft. galvanized

3403603: 130 ft. stainless steel

A retraction that lasts.
Our heavy-duty main spring maintains its exact retraction for the life of the product; just one more example of DBI/SALA's commitment to excellence in quality.

Ultra-Lok® SRL's

To provide **maximum comfort and minimal weight**, Ultra-Lok® SRL's come with a durable glass-filled polyurethane housing, a 3/16" wire rope lifeline and aluminum side plates. For added security, Ultra-Lok® systems have an anti-ratcheting twin-disc brake system with an audio indicator to let you know it is functioning properly.



3504433

- Corrosion-resistant stainless steel working components
- Reserve lifeline retention system
- 3/16" galvanized steel wire rope (stainless avail.)
- Self-locking swivel snap hook with impact indicator
- Swiveling anchorage loop to prevent twisting of life-line
- 20 ft. long
- Weight = 9 lbs.

Similar Models:

- 3504434: 20 ft. stainless steel
- 3504430: 30 ft. galvanized
- 3504431: 30 ft. stainless steel
- 3504450: 50 ft. galvanized
- 3504451: 50 ft. stainless steel
- 3504453: 35 ft. spectra synthetic rope



Heavy Duty SRL's

Heavy Duty SRL's feature a cast aluminum housing to keep them lightweight, yet **able to resist dents and damage**. Among our original models, they are industry-proven to be some of the most reliable fall protection devices on the market.



3000057

- Centrifugal ratchet type brake
- Reserve lifeline retention system
- 3/16" galvanized steel wire rope
- Galvanized steel anchorage shackle
- Self-locking swivel snap hook with impact indicator
- 20 ft. long
- Weight = 12 lbs.

Similar Models:

- 3000058: 20 ft. stainless steel
- 3000150: 39 ft. galvanized
- 3000151: 39 ft. stainless steel

Talon™ Web SRL's

Talon SRL's are engineered for reliable protection that locks when it should; won't lock when it shouldn't. The **extremely lightweight design** (just under three pounds!) and **quick-connect system** gives you freedom of movement without compromising your safety.



3101001 Built-in Quick Connector Series

- 1" wide nylon webbing lifeline
- Quick-connector handle
- Self-locking swivel snap hook with impact indicator
- 8 ft. long
- Weight = 3.0 lbs.

Similar Models:

- 3101000: with 9503175 snap hook
- 3101002: with 2000523 steel carabiner (3/4" opening)
- 3101003: with 2000108 steel carabiner (2" opening)
- 3101004: with 2004339 alum. hook with eye (3/4" opening)
- 3101005: with 2007199 steel swiveling carabiner with eye (3/4" opening)
- 3101006: with 9510057 steel flat rebar hook with eye (2-1/4" opening)
- 3101007: with 2007153 aluminum snap hook with eye (2-1/4" opening)



3101009 Built-in Order Picker Connector Series

- 1" wide nylon webbing lifeline
- Order picker connector
- Self-locking swivel snap hook with impact indicator
- 8 ft. long
- Weight = 3.3 lbs.

Similar Models:

- 3101008: with 9503175 snap hook
- 3101010: with 2000523 steel carabiner (3/4" opening)
- 3101011: with 2004339 alum. hook w/ eye (3/4" opening)
- 3101012: with 2007199 steel swiveling carabiner w/ eye (3/4" opening)



Horizontal Lifeline Systems



You can always depend on DBI/SALA horizontal safety systems for mobility and fall protection while working up high and exposed. Built with DBI/SALA durability and portability, the light-weight systems are reusable again and again. From maintenance to bridge work, construction to manufacturing, our systems make it easy to comply with safety standards. Every horizontal safety system is engineered to keep you safe—with total confidence.

SayflinTM

Horizontal Lifeline Systems—Simple, Reliable, Safe!

SayflinTM horizontal systems are not only light-weight and easy to install, they are also extremely portable. Just disassemble and take to the next job. Engineered with DBI/SALA attention to quality and detail, the SayflinTM systems will work alongside you with absolute safety and reliability.

7600020

SayflinTM Synthetic Horizontal Lifeline System

- Easily installed with no special tools or equipment
- Lightweight, only 12 lbs.
- Rope lifeline assembly with tensioner
- Two tie-off adapters
- 20 ft. long
- Carrying/storage bag

Similar Models:

7600030: 30 ft. system

7600040: 40 ft. system

7600050: 50 ft. system

7600060: 60 ft. system



7602020

SayflinTM Cable Horizontal Lifeline system

- Cable lifeline assembly
- Turnbuckle to tension
- ZorbitTM energy absorber
- Cable grip
- 20 ft. long

Similar Models:

7602030: 30 ft. system

7602040: 40 ft. system

7602050: 50 ft. system

7602060: 60 ft. system

7602070: 70 ft. system

7602080: 80 ft. system

7602090: 90 ft. system

7602100: 100 ft. system



Order Picker System Web SRL/Cab-Mount Bracket

Our Order Picker fall protection system is easy to install and stays out of the way when you need to be protected from fall hazards in order pickers. For maximum flexibility to meet height limitations and clearance requirements, the cab mount bracket has been carefully engineered for mounting in a number of different positions on the top and bottom of the cab ceiling.



3103120

- Cab-mount bracket
- Fastening hardware
- 3103108 Ultra-Lok[®] web SRL, 11 ft. long

7401031

ZorbitTM Kits

- Allows you to customize your own system safely
- ZorbitTM energy absorber
- 2 shackles
- 2 bolts/nuts

Similar Models:

7401032: with turnbuckle

7401033: with turnbuckle, thimble and cable clips (just add your own cable)



Anchorage Connectors



DBI/SALA manufactures the industry's widest range of anchorage connectors, **combining ease of use, light weight and high strength** (5000 lb. min. tensile strength). No matter what you are connecting to, DBI/SALA has a connector to get the job done and keep you safe in case of a fall.

First-Man-Up™ System
A simple and easy way to anchor a fall protection device to an overhead location and beyond normal reach.

1003000 Pass-thru Tie-off Adapter

- 1-3/4" polyester strength member
- 3" wide polyester wear pad
- 3 ft. long (other lengths available)

Similar Models:

1003006: 6 ft. length

1002106: 6 ft. adjustable



2101630 D-ring Anchorage Plate

- Bolt or weld to structure
- Two 1/2" dia. attachment holes
- Stainless steel
- Plate size 1/4"x2"x4-1/4"

Similar Models:

2101634: with raw steel



2104519 First-Man-Up™ System

- 6 to 12 ft. adjustable pole (2104523)
- Tie-off adapter tool (2104521)
- Hook attachment (2104522)
- Tie-off adapter (1003000)
- Carrying bag (9511597)
- Training video (5902302)

Similar Model:

2104520: 8 to 16 ft.

adjustable pole



New Product

Adjustable Width Trolley for I-Beams

Designed for use with self-retracting lifelines on horizontal I-beams.

2103143 Trolley

- Attachable at midpoint
- Minimum turn radius of 7"
- Fits 3"-8" flange width and up to 11/16" thick flat or tapered beams
- Non-corrosive double-shielded wheel bearings



1201390 Scaffold Choker with D-ring

- 17" long
- Fits 3" max. diameter structure



1220145 Girder Grip

- Pivoting wing-bar provides the girder lock
- Finger grips in center for easy tightening
- Fits .79" to 1.25" (20-32mm) diameter hole in a .25" to 1.25" (6-32mm) thick steel beam
- With 5 ft. EZ Stop® II shock absorbing lanyard



Fall Protection



Whether for public safety through debris containment or personal safety through fall protection, **DBI/SALA Net Systems** offer a safe, practical and cost effective solution. These rugged and easy to install nets meet or exceed national and international safety requirements and are manufactured to the strictest quality and safety standards.

ADJUST-A-NET 4100100

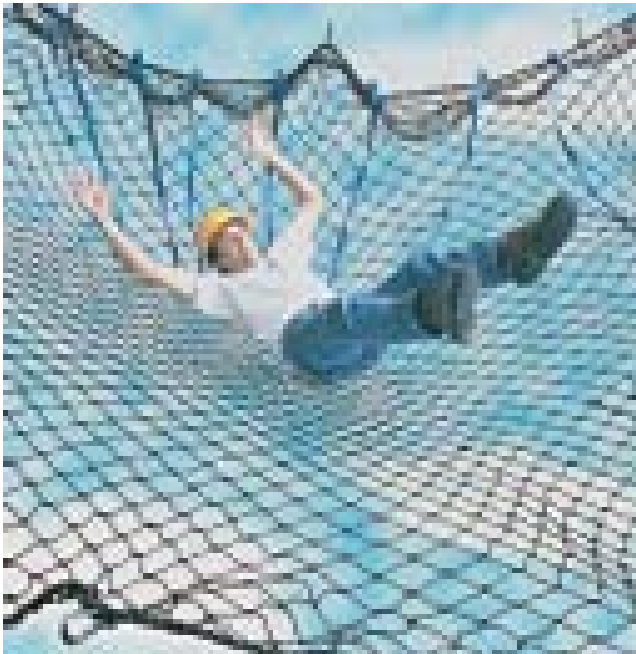

The Adjust-A-Net infinitely adjustable fall protection and debris containment net systems are so versatile and adaptable that you only need to keep a few in inventory. Easily adjust on the ground or in the air in no time at all.

- Quick-adjust buckles reduce sag and allow you to precisely fit the net to your opening
- 3 1/2" mesh has a UV-resistant coating to resist abrasion
- Inspection-ready test cords for safety evaluations
- Rugged steel snap hooks every
- 15 ft. x 25 ft.

Similar Models:

- 4100101: 20 ft. x 30 ft.
- 4100102: 25 ft. x 50 ft.
- 4100400: 15 ft. x 25 ft. with debris
- 4100401: 20 ft. x 30 ft. with debris liner
- 4100402: 25 ft. x 50 ft. with debris liner



VERTICAL NET 4100300



DEBRIS CONTAINMENT AND GUARDRAIL SYSTEM

DBI/SALA uses bright orange vertical netting which provides a dual role-debris containment and as a worker guardrail near building edges. This tight mesh dependably contains objects of any size and also serves as a wind barrier. The nets are easy to install, remove and relocate; saving you substantial time and money.

- Exceed OSHA's 200 lb. lateral force strength requirements
- Highly visible, UV stabilized and flame retardant polyethylene mesh
- 50 E-Z clips for easy and secure installation
- 20 tie-down fastener plates to replace toe boards and firmly set the nets
- 48" X 100 ft.

Similar Models:

- 4100203: 48" x 100 ft. without clips and plates
- 4100303: 66" x 100 ft.
- 4100202: 66" x 100 ft. without clips and plates



4100003

ATTACHMENT KIT

- 50 E-Z clip
- 20 tie-down fastener plates





8304000

**Winch/SRL/tripod
Combination**



8302050

**Davit Arm and base
with Salalift® winch**



RESCUE SYSTEMS

For utmost confidence, DBI/SALA's packaged rescue systems are a perfect rescue/retrieval safety system solution. You can go onto the job knowing that your equipment is ready to go; totally compatible and built with DBI/SALA quality.

- Lightweight, portable confined space entry system
- Salalift® winch with 60 ft. of 1/4" galvanized cable (8101000) and carrying bag.
- Back-up sealed self-retracting lifeline with emergency retrieval and 50 ft. 3/16" galvanized cable (3400115), mounting bracket (3401065) and carrying bag
- 7 ft. aluminum tripod (800000)
- Legmount pulley (8003238)
- Tripod mounting base (8005048)

Similar Models:

8300001: Tripod and winch only

8301000: Tripod and SRL only

5304010: Tripod, SRL, and Salalift® II winch (8102001)

- Versatile alternative when a tripod is unfeasible
- Davit arm with portable base (8002032)
- Winch with 60 ft. 1/4" galvanized cable (8101000)
- Winch bag

Similar Models:

8302060: with SalaLift® II winch only

8303030: with sealed SRL only



6116026 AND 6116027

**SRL Ladder Mounting
Anchorage System**

- Removable anchorage for fixed ladders
- Top mounting bracket assembly (removable)
- Bottom mounting bracket (permanently attached)
- Self sealed-retracting lifeline hangs from top bracket (order separately)

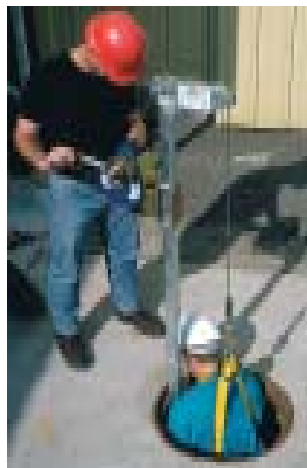

**6116038 and
6116027**

Ladder Mast Anchorage Systems

- Removable anchorage for fixed ladders
- Removable ladder mast with pulleys and mounting bracket for winch or SRL
- Bottom mounting bracket (permanently attached)
- Salalift® II winch or sealed SRL attaches to mast (order separately)

TRAILER DEMOS

Workers from all over the world enjoy learning from our hands-on presentations of DBI/SALA fall arrest, restraint and rescue equipment. Our Mobile Test Trailers come right to your job site, equipped with a drop-test stand and force measuring instruments to demonstrate the arresting forces workers could (and would) experience during a fall. We also demonstrate how to use, care for and maintain your DBI/SALA safety equipment.

**CALL ONE OF OUR
EXPERIENCED TEAM MEMBERS**

TODAY FOR MORE INFO



Confined Space

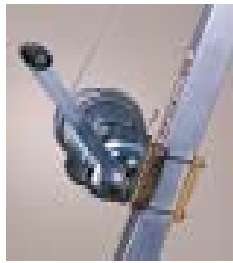

8103000
Material Winches



3400115
Sealed SRL
Fall Protection &
Rescue Device

It is important to use this basic winch for material lifting *only*; not for lifting workers.

- 60 ft. of 3/16" galvanized cable
- 4.1:1 gear ratio
- Quick mount bracket
- 350 lb. rating

Similar Models:

8300201: with 8000000 - 7 ft. tripod

8300202: with 8000010 - 9 ft. tripod

Note: When there is no fixed ladder or support, you also need to use a back-up or secondary personal fall arrest system.

Sealed self-retracting lifelines with emergency retrieval features are spring tensioned for normal work motions. However, if you slip or fall, the sudden jerk in the cable activates the braking mechanisms and brings you to a stop. The system then provides emergency retrieval.

- Input handle with primary brake
- Overload device in winch drive
- Fall arrest capabilities in retrieval mode
- Heat treated alloy steel gears, alloy steel shafting and sealed ball bearings
- 50 ft. of 3/16" galvanized cable
- Steel indicating swivel hook
- Quick-mount bracket 3401065 and carrying bag 9503515

Similar Models:

3400108: with stainless steel cable

3400311: 85 ft. galvanized cable

3400309: 85 ft. stainless

3400509: 130 ft. galvanized cable

3400508: 130 ft. stainless steel



8102001
SalaLift® II Winch
Lightweight Work
Support & Rescue Device

This second generation Salalift® winch exceeds all industry requirements, providing superior performance and exclusive technology for dependability and ease of use.

- 6:1 gear ratio with average lifting speed of 12.75 ft./min.
- Lightweight (35 - 37 lbs.)
- Quick-mount bracket
- Free-wheel mode for operator maneuverability
- Overload clutch
- Polyethylene housing cover
- Superior corrosion resistance
- Safety hook with impact indicator
- Reserve lifeline
- 60 ft. - 1/4" galvanized cable
- Winch bag

Similar Models:

8102003: 60 ft. - 1/4" stainless cable

8102009: 90 ft. - 3/16" galvanized cable

8102011: 90 ft. - 3/16" stainless cable

8102005: 120 ft. 3/16" galvanized cable

8102007: 120 ft. 3/16" stainless cable

8101000

SalaLift® Winch
Heavy Duty Support & Rescue
Device



Whether raising, lowering or supporting people or materials, the sturdily constructed Salalift® has a triple braking system to provide added safety. The gear system comes with two-speed input so raising and lowering is quick and easy; just rotate the handle to lower or raise your load to the desired position.

- Two independent centrifugal brakes, one dead man type brake
- Two-speed input: primary 6.6:2; secondary 3.3:1
- Steel gears within oil bath
- Ball bearing type construction
- Heat treated cast aluminum housing
- Load limiting input handle
- Level wind cable device
- 60 ft. long - 1/4" galvanized cable
- Quick mount bracket
- Winch bag

Similar Models:

8101002: 60 ft. - 1/4" stainless steel cable

8101004: 120 ft. - 1/4" galvanized cable

8101006: 120 ft. - 1/4" stainless cable

AXIAL BLOWERS



9514



9514-25



9506-01



9506-25

9514 AC AXIAL BLOWER W/CANISTER-15

Engineered for convenience, this 8" axial blower is an all-in-one ventilation system. The design allows ducting to collapse into a built-in canister for easy storage. The unit can also be stored vertically to use a minimum amount of space. Includes blower, built-in storage canister and 15 ft. of ducting. Certified to CSA standard C22.2 NO 113.

9514-25 AC AXIAL BLOWER W/ CANISTER-25

Like the 9514, this complete ventilating system offers 25 feet of attached ducting that is stored in the built in canister. Remarkably lightweight at only 46 lbs., the 8" axial blower is very easy to use. Certified to CSA standard C22.2 NO 113.

9506-01 DC AXIAL BLOWER W/CANISTER-15

This complete, all-in-one ventilation system includes an 8" axial blower powered by a 12 volt DC motor, 15' of ducting and a built in storage canister. The handle and feet make this light weight system very portable and easy to store.

9506-25 DC AXIAL BLOWER W/CANISTER-25

Similar to the 9506-01, this complete ventilating system includes 25' of attached ducting that is stored in the built in canister, and can be set upright for minimum storage space. Remarkably lightweight at only 44 lbs., this 8" axial blower is very easy to use.

ALLEGRO
INDUSTRIES

9500-03

AXIAL INLET ADAPTER

Useful to utility and construction workers, this adapter allows an axial blower to draw fumes and other contaminants out of a work area quickly and effectively. Ducting mounted to the adapter will disperse contaminated air away from the work area. It can be used on any Allegro 8" axial blower and allows a single blower to work in two completely different applications.



9513

AC AXIAL BLOWER

With the highest output available from an 8" axial blower, this compact unit offers light weight and high output from an AC electric motor. It is designed with tough steel construction, a durable grill, convenient carry handle and rubber feet. Its small profile means easy storage. Certified to CSA standard C22.2 NO 113.



9513-50 HEATER

Designed for use with 9513 Axial Blower only. High output propane heater features solid state ignition, flame indication light and flow control.



Model #	Description	Free Air	One 90° bend	Two 90° bend	Weight	H.P.	Power
9514	AC Axial Blower w/canister-15	1275	661	582	36 lbs.	1/3	3A/115V
9514-25	AC Axial Blower w/canister-25	1275	661	582	46 lbs.	1/3	3A/115V
9506-01	DC Axial Blower w/canister-15	1150	595	530	34 lbs.	1/4	13A/12V
9506-25	DC Axial Blower w/canister-25	1150	595	530	44 lbs.	1/4	13A/12V
9513	AC Axial Blower	1275	661	582	20 lbs.	1/3	3A/115V

Confined Space

ALLEGRO
INDUSTRIES



Deluxe Work Tent

Easy to use and very durable, the Deluxe Work Tent features quick set-up from the inside or outside with fiberglass rod frame. These frames are uniquely designed to not pull out or poke through the fabric. A handy attached roll-up flap provides compact storage, easy transport, and means no missing storage bag. Offered in three sizes, it is available in a one door design with zipper closure, or two door design with one zipper and one roll-up door. The pitch roof style provides extra headroom, structural strength and repels snow and water. Frame rods are bolted for increased stability and the unbreakable hinges are made of rolled steel. The free standing structural stability is excellent in windy conditions. For safety, there's a high visibility reflective stripe on the outside, and the gray color of the tent allows proper lighting for color matching. Included is a blower duct tube in the rear of the tent, and a covered window.

Model	Description	Door	Depth	Width	Height
9401-66	Deluxe work tent	1	6'	6'	6-1/2'
9401-86	Deluxe work tent	1	8'	6'	7-1/2'
9401-88	Deluxe work tent	1	8'	8'	7-1/2'
9402-66	Deluxe work tent	2	6'	6'	6-1/2'
9402-86	Deluxe work tent	2	8'	6'	7-1/2'
9402-88	Deluxe work tent	2	8'	8'	7-1/2'

Height measured from peak of roof



9401-50 Tent Heater

The lightweight Tent Heater offer the rugged, heavy duty design of all housing with enclosed heating elements and a sealed motor. This powerful heater will raise the temperature 50° in a work tent. It is UL listed, CSA approved, requires 110V AC, and offers 1500 watts of 5000 BTU with 115 cfm airflow. 12" x 8" x 12", 12 lbs.



9403-66

9403-66 Economy Tent

Handy 6' x 6' size offers a roll-up door with Velcro® attachments. Made of lightweight, high quality white polyester, with 5'8" of head room. Vent holes are located in the rear of the tent. This tent offers the same quick set-up suspension as the Deluxe above and comes with a handy polyethylene storage bag.

9401-01 Guard Rail Tent

This easy to assemble tent attaches to all standard guard rails. Extending 31" above the top rails. Extending 31" above the top rail of the guard rail, it is over 6' tall. Its quality polyester construction protects manholes from rain and weather, and Velcro attachments secure the tent against wind. Includes a high visibility reflective strip on the outside for safety. Includes storage bag.



9401-01

Confined Space



INDUSTRIAL SADDLE VENT®

CONFINED SPACE ENTRY VENTILATION TECHNIQUE



The Saddle Vent® was invented by a professional tank cleaner to make it easy for his workers to enter and exit a confined space. The Saddle Vent® takes up only 3 inches in a manhole and functions as an air conduit. Eight inch air hose is attached to both ends of The Saddle Vent® and placed in the entry access hole, thus eliminating the need to remove the hose each time entry or egress is required. The Saddle Vent® revolutionizes confined space operations by offering a level of safety and productivity that has never been available. One model is available for industrial manhole work, and a specific model is designed for doing tank entry work. The Saddle Vent's® unique air flow design does not reduce air flow to the worker.

CONFINED SPACE ENTRY VENTILATION "DO IT RIGHT THE FIRST TIME"

INDUSTRIAL MODEL SADDLE VENT® #SV-189

THE SADDLE VENT® VENTILATION TECHNIQUE

SVB-G8
GAS BLOWER

SV-90
ELBOW

SV-UM
UNIVERSAL MOUNT

SVH-6
DUCT

SVH-DC25
DUCT CARRIER

SV-189
SADDLE VENT

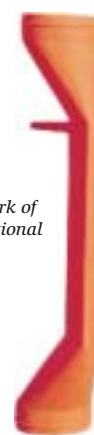

Saddle Vent®
is the
Registered Trademark of
Air Systems International

Length: 43.5"
Width: 14.5"
Depth: 3.5"
Top Opening: 8" O.D.
Bottom Opening: 8" O.D.
Construction: .25"
Polyethylene
Temperature Rating:
+ 250°F Melt Temp.
- 158°F Brittleness
Color: Safety Orange
U.S. PATENTS
#4,794,956
#4,982,653
CANADIAN PATENT
#1,286,999
EUROPEAN PATENT
#0376425
AUSTRALIAN PATENT
#120711



Air duct set in a manhole limits light and restricts the worker's entry & egress.

The Saddle Vent® when set in place, allows unrestricted entry and egress and allows for more rapid confined space emergency rescue.

The Saddle Vent® ventilator provides continuous access to the manhole for either entry or egress. Traveling in and out of the confined space can now be done quickly and safely. The Saddle Vent® increases worker productivity as well as the ability to perform confined entry rescue. The entire Saddle Vent® system can be completely set up in less than five minutes. Eight inch air duct is installed on the bottom of The Saddle Vent® and run to the bottom of the manhole. This allows fresh air to be supplied to the workers and displaces any harmful gases that may be deadly for the occupants. The use of the 90° elbow removes the severe kink in the air duct and allows for rotation of the intake duct to any desired position at the street level.



Confined Space

TANK SADDLE VENT®

FIRE RETARDANT

APPROVED BY U.S. NAVY

DESIGNED FOR SMALL OPENINGS

STANDARD
TANK
MODEL
SV-189T*



Special
Tank
Model
Saddle Vent®
with
installed 8"
"Navy Style"
stainless steel
twist lock hose
clamps is
pictured here
at left

NAVY MODEL
SV-189TC

TANK MODEL DIMENSIONS

8" O.D.

Ideal For Horizontal
Tank Entry



8" O.D.



The patented Tank Model Saddle Vent® is specially designed to fit 18"W x 20"L oval tanks. Pictured above, the tank model is installed in the void entry area with complete entry and egress access to the ladder. Also, note that the required metal guard is left in place without interference from the Saddle Vent®.

Select a blower based
on environmental
conditions and the
size of the confined
space

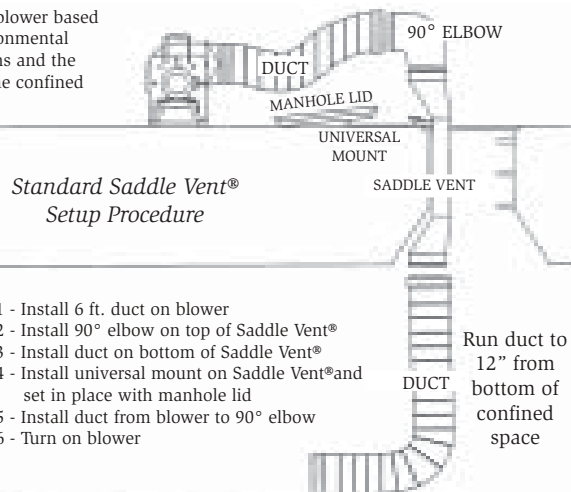

THE SADDLATOR™

PNEUMATIC POWERED SADDLE VENT® BLOWER

← AIR FLOW →



90° bolt-on elbow
provided with unit
Compressed air
hose to air source
Venturi-style air
blower
SV-189 industrial
Saddle Vent®
Ideal for hazardous
environments

MODEL SV189-
29
PICTURED

APPLICATIONS

- Provides positive pressure ventilation to supplement confined space entry operations in large work areas or tanks
- Air operated Venturi blower has no moving parts
- Ideal for use in hazardous environments or smoke removal
- Static ground connection provided on blower head
- Total weight: 14 lbs.
- Cast aluminum blower head *Air fitting required is optional*

ORDERING INFORMATION

MODEL	DESCRIPTION
SV189-29	Industrial model SADDLATOR™ w/ elbow
SV90-29	90° bolt-on elbow to fit SADDLATOR™
SV189T-29	Tank model SADDLATOR™
H-50-5	1/2" compressor connect hose - 50 ft.
H-50-12	3/4" compressor connect hose - 50 ft.

SADDLATOR™ PERFORMANCE

Inlet Pressure (psi)	Air Flow* (cfm) Free Air	Air Consumption (scfm)
10	1546	33
20	1900	47
30	2250	60
40	2300	73
50	2600	85
60	2800	98
80	3350	128
100	3800	155

* Installing 25 ft. of duct on the base of the "SADDLATOR™" will result in approximately a 15% to 25% flow loss - all above calculations are approximations



APPROVED and $\text{C}\epsilon$ REGISTERED FANS AND BLOWERS



PORTABLE FANS AND BLOWERS INDUSTRIAL GRADE • HEAVY DUTY

SINGLE SPEED ELECTRIC BLOWER

SVB-E8

- GFI Power Cord
- 3/4 HP electric motor, 115 VAC, 12 amp
- 1570 cfm free air delivery
- 8" intake and exhaust flange
- Powder coat steel frame
- Steel safety guards
- Weight: 53 lbs.



2-SPEED ELECTRIC BLOWER With GFI

SVB-E8-2

- GFI Power Cord
- 3/4 HP electric motor, 115 VAC, 12 amp
- 750 low/1570 high cfm free air delivery
- 8" intake and exhaust flange
- Powder coat steel frame
- Steel safety guards
- Weight: 64 lbs.



GASOLINE POWERED BLOWER

Meets CALOSHA emissions standards

SVB-G8

BRIGGS & STRATTON ENGINE

- 5 ft. remote flexible steel exhaust hose with custom gas-tight muffler to prevent intake of CO exhaust
- Steel safety guards
- 3.5 HP B&S motor
- 8" intake and exhaust flange
- Aluminum non-sparking blower wheel
- 3000 cfm max free air delivery
- Four independent rubber engine vibration mounts
- Weight: 47 lbs.



HONDA ENGINE

- 4 HP Honda engine optional - Order Model SVB-G8-H

PROPANE ENGINE

- Model SVB-G8P - Includes propane conversion kit installed Briggs & Stratton engine and propane tank provided

ECONOMY ELECTRIC BLOWER

SVB-E8EC

- 1/2 HP electric motor, 7.9 amps, 60 Hz, 115 VAC
- Steel safety guards
- GFI power cord
- Powder coat steel frame
- 8" exhaust and optional 8" inlet flange
- 1390 cfm free air delivery
- Weight: 37 lbs.

GFI Installed



EXPLOSION-PROOF ELECTRIC BLOWER

SVB-E8EXP

- 3/4 HP UL listed motor, 115 VAC, 12 amp
- Explosion-proof switch installed and wired
- 8" intake and exhaust flange plug
- 1570 cfm free air delivery
- Approved for Class I, Div. 1, Group D Class II, Div. 1, Groups E, F, G
- 8" intake and exhaust flange
- Powder coat steel frame
- Steel safety guards
- Weight: 79 lbs.

Wired For Use
With 25 Ft. Cord
No Plug

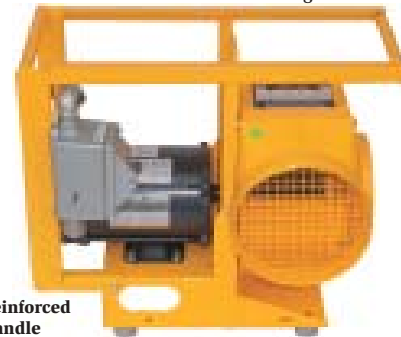

Standard with reinforced
dual carry handle

PNEUMATIC AIR POWERED BLOWER

SVB-A8

- Ultra-quiet operation - under 80 dbA
- Runs off any compressed air source
- Ideal for hazardous locations
- Adjustable flow output regulator
- In-line moisture separator / lubricator provided as standard
- 3000 cfm free air delivery at max psi and cfm
- Air Systems' unique muffler and oil coalescing filter installed at air motor discharge
- 8" intake and exhaust flange
- Powder coat steel frame
- Steel safety guards
- Weight: 49 lbs.

Intrinsically Safe Operation



International blowers available with 50 Hz/220 VAC/1 phase.

Confined Space



APPROVED and CE REGISTERED FANS AND BLOWERS



PORTABLE FANS AND BLOWERS

CONFINED SPACE VENTILATION KITS

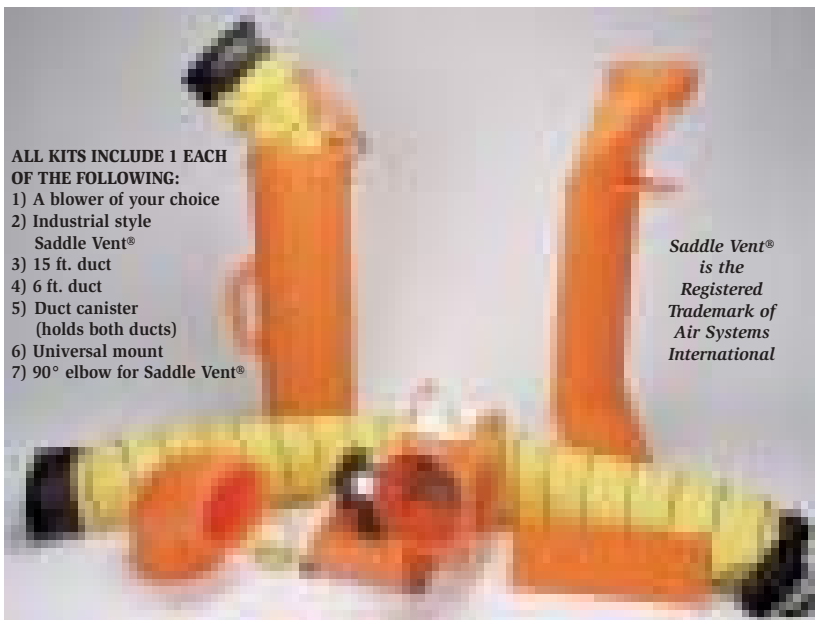

ALL KITS INCLUDE 1 EACH OF THE FOLLOWING:

- 1) A blower of your choice
- 2) Industrial style Saddle Vent®
- 3) 15 ft. duct
- 4) 6 ft. duct
- 5) Duct canister (holds both ducts)
- 6) Universal mount
- 7) 90° elbow for Saddle Vent®

Saddle Vent® is the Registered Trademark of Air Systems International

Model	Description
SVB-E8SCUP	Standard Electric Blower Kit
SVB-E82CUP	2-Speed Electric Blower Kit
SVB-G8CUP	Gasoline Blower Kit
SVB-A8CUP	Pneumatic Blower Kit
SVB-E8XCUP	Explosion-Proof Electric Blower Kit
SVB-E8CUP	Economy Electric Blower Kit (PICTURED AT LEFT)

Saddle Vent® Ventilation Technique



PORTABLE AXIAL FANS AVAILABLE IN AC OR DC VERSIONS

CE Approved Registered

AC VERSION

Model SVF-8AC

- 1/3 HP - 115 VAC
- 8" diameter outlet
- Weight: 22 lbs.
- CSA approved motor and fan unit
- 1395 cfm free air
- 72 dbA @ 3 ft.

DC VERSION

Model SVF-8DC

- 12-volt DC
- 1/6 HP, 13 amps
- 10' power cord with battery clips
- In-line 20 amp fuse holder
- 1170 cfm free air
- 8" diameter outlet
- 72 dbA @ 3 ft.
- Weight 22 lbs.

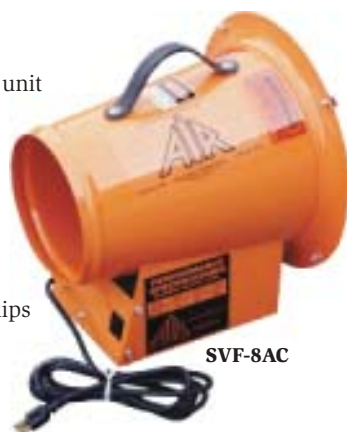

SVF-8AC

AIR SYSTEMS manufactures a combination ventilation fan and duct storage unit to meet the most demanding customer needs. Our rugged polyethylene duct canister is securely attached to one of our rugged light-weight fans to make an ideal ventilator for the customer who wants a one piece ventilation package.

Note: All electric blowers and fans are CSA approved as a unit.

CANISTER FAN



SVF-15ACAN

weight: 39 lbs. w/25' Duct
35 lbs. w/15' Duct

Model	Description
AXIAL FANS	
SVF-8AC	AC axial fan - 1395 cfm free air
SVF-8ADC	DC axial fan - 1170 cfm free air
DUCT CANISTER FANS	
SVF-6ACAN	AC axial canister fan with 6 ft. duct installed - 890 cfm
SVF-15ACAN	AC axial canister fan with 15 ft. duct installed - 870 cfm output
SVF-25ACAN	AC axial canister fan with 25 ft. duct installed - 858 cfm output
SVF-6DCAN	DC axial canister fan with 6 ft. duct installed - 825 cfm
SVF-15DCAN	DC axial canister fan with 15 ft. duct installed - 815 cfm output
SVF-25DCAN	DC axial canister fan with 25 ft. duct installed - 796 cfm output



CONFINED SPACE BLOWERS BLOWER MOTOR SPECIFICATIONS



REFERS TO STANDARD BLOWERS

BLOWER PART NUMBER	MOTOR SPECIFICATIONS	CFM FREE AIR	CFM w/ DUCT 25' 8" Duct, 1-90° bend	WEIGHT POUNDS	STANDARD BLOWER TECHNICAL FEATURES
SVB-E8-2 2-speed electric	3/4 HP - 115 VAC - 12 amp - 2 speed TEFC motor, low 1140 rpm, high 1725 rpm, built-in GFI on/off power cord	750 LOW 1570 HIGH	490 LOW 1047 HIGH	64 lbs.	
SVB-E8 1-speed electric	3/4 HP - 115 VAC 12 amp pre-wired TEFC motor - installed GFI cord	1570	1047	53 lbs.	
SVB-E8EXP explosion-proof UL listed motor	3/4 HP - 115 VAC - 12 amp, factory wired - no plug Class I, Div. 1, Group D Class II, Div. 1, Groups E, F, G	1570	1047	60 lbs.	
SVB-G8 gasoline SVB-G8-H (Honda)	3.5 HP Briggs & Stratton gasoline engine with 5ft. Remote flexible steel exhaust hose and custom gas-tight muffler	MIN 1500 MAX 3000	MIN 1040 MAX 1725	47 lbs.	
SVB-G8P propane	3.5 HP Briggs & Stratton w/propane conversion unit installed - 5ft. Remote flexible steel exhaust hose supplied	MIN 1500 MAX 3000	MIN 1040 MAX 1725	47 lbs.	
SVB-A8 pneumatic (air driven) intrinsically safe with low noise output motor	4 HP pneumatic air motor In-line particulate/water filter w/drain 2nd stage in-line lubricator, opening inlet pressures from 10-90 psi, operating inlet flow requirements 5-30 cfm. Adjustable air inlet pressure regulator with pressure gauge special low-noise muffler-under 80 dbA	1500 @ Minimum psi and cfm 3000 @ Maximum psi and cfm	1040 @ Minimum psi and cfm 1725 @ Maximum psi and cfm	50 lbs.	
SVB-E8EC economy electric	1/2 HP - 115 VAC - 7.9 amps - 60 Hz pre-wired with GFI on/off power cord	1390	973	37 lbs.	

- STANDARD BLOWER TECHNICAL FEATURES**
- Solid rubber isolation mounts on all models
 - Steel welded safety guards on intake and exhaust
 - Thermal overload protectors on all electric models
 - All steel housing, frame, and carry handle - shaft guard standard
 - Universal frame and housing for all models - modular components
 - All aluminum non-sparking blower wheels
 - Blower wheels dynamically balanced to 3000 rpm
 - Ribbed 8-inch flanges on intake and exhaust to accommodate standard 8" ducting
 - Continuous duty electric motor - CSA approved
 - CSA approved electric blowers
 - TEFC farm duty electric motor - dual voltage rated - 115/230 VAC
 - Motor temperature rating -30°F to 105°F
 - Gasketed capacitor cover
 - Designed for use in severe conditions



"BELL" CUFF AND BUCKLE STANDARD ON BOTH ENDS

BLOWER HOSE AND ACCESSORIES

- Vinyl polyester ventilation air duct hose
- 8" diameter with vulcanized external wear strips - custom sizes available on request - duct sizes to 36" diameter available
- Internal steel reinforced wire hoop - 4" pitch
- 6" long attachment cuff with adjustable belt straps on both hose ends
- Insulated and conductive duct available - call for specific duct materials to meet special applications

Model	Description
SVH-6	16 ft. Vinyl Hose Duct - 8" Diameter
SVH-15	15 ft. Vinyl Hose Duct - 8" Diameter
SVH-25	25 ft. Vinyl Hose Duct - 8" Diameter
SVH-CND825	25 ft. Conductive Duct - 8" Diameter
SVH-CND815	15 ft. Conductive Duct - 8" Diameter
SVH-CND86	16 ft. Conductive Duct - 8" Diameter

DUCT CARRIERS



Standard Polyethylene

- Locking lid
- Carry handle
- Polyethylene construction
- Holds up to 50' of 8" diameter duct
- Custom sizes avail.

CUSTOM GALVANIZED
SIZES AVAILABLE

8" DUCT TO DUCT CONNECTOR



GALVANIZED STEEL

SVH-88C

CUSTOM SIZES AVAILABLE

SV-90 Standard
SV-90T Tank
90° Elbow for Top of Vent



SV-UM
Saddle Vent®
Universal Mount



Custom Duct Transitions



Ask for details

IN-LINE FILTER HOLDERS

Use for
Odor and
Dust
removal



Galvanized
Steel
Standard

FH24-8

- Hold a 24" x 2" filter
- 8" duct flange on one end
- Allows user to filter intake or discharge air
- Available in stainless steel or aluminum
- Custom sizes and designs are available

FILTER INFORMATION

ASI-242C Carbon Odor Removal Filter, 24"x24"x2"
FLTR004 Dust Filter, 24"x4"x2"

Other Filters Available upon request



Instrumentation

MicroMAX PRO MULTI-GAS DETECTOR



Now with **VOICE ASSIST** for added safety, the MicroMAX PRO is designed to provide the ultimate in personal safety. It's OSHA compliant, and has a rugged case that provides superior RFI/EMI shielding, as well as dust, water and impact resistance. Additionally, it is designed, tested and manufactured under strict ISO 9001 standards, and is UL classified for use in Class I, II, III Division I, Groups A, B, C, D, E, F, G.

The MicroMAX PRO combines diffusion and built-in internal sampling pump systems for simultaneously monitoring 1 to 5 gases*. The popular internal pump allows for easy pre-testing in confined spaces and provides almost instantaneous reading of gas concentrations. In order to save power, the pump can be switched off and the diffusion mode will take over.

MicroMAX PRO has present and field selectable alarms. Both the audible and visual alarms warn the user if the oxygen levels are either too low or enriched, combustible gas is present or toxic gas is present or toxic gas levels are too high. The toxic gas alarms can be easily adjusted in the field from immediate to TWA. And, alarms are also activated in case of sensor failure, low battery voltage, pump blockage or low air flow.

Calibration is easier than ever before; it's all automatic; no tools, screws or stopwatch required. Simply place in calibration "Mode", introduce calibration gas and wait for voice/display indicating calibration is complete. A NiMH rechargeable battery pack and 4-hour charger are now included with each monitor. However, the flexibility of operating the monitor with alkaline batteries is still retained. Ask about Included Accessories.

ADDITIONAL SENSORS AVAILABLE FOR:	Range:
E = Ammonia (NH ₃)	0-200 PPM
F = Chlorine (Cl ₂)	0-20 PPM
G = Chlorine Dioxide (ClO ₂)	0-10 PPM
H = Sulfur Dioxide (SO ₂)	0-20 PPM
J = Phosphine (PH ₃)	0-20 PPM
K = Nitrogen Dioxide (NO ₂)	0-50 PPM
L = Hydrogen Cyanide (HCN)	0-200 PPM
M = ComboTox (CO & H ₂ S)**	0-500 PPM
N = Combustible (%by Volume)	0-100% CH ₄

** counts as TWO sensors

Part #	Description
MPRO--4ABC	Multi-Gas Detector w/Voice Assist

BASEUNIT	# OF SENSORS	GAS*	RANGE
MPRO	4	A = Oxygen(O ₂)	0 - 40% by volume
		B = Combustible (LEL)	0 - 100%
		C = Carbon Monoxide (CO)	0 - 999PPM
		D = Hydrogen Sulfide(H ₂ S)	0 - 500PPM

MicroMAX MULTI-GAS DETECTOR

Designed to provide personal safety, the MicroMax is OSHA compliant. Its rugged aluminum case provides superior RFI/EMI shielding, as well as dust, water and impact resistance. MicroMax is designed, tested and manufactured under strict ISO 9001 quality systems, and is UL classified and CSA certified intrinsically safe for use in Class I, Division I and II, Groups A, B, C, and D areas. Worker safety is our business, and Lumidor continually improves its gas detectors' quality and features. Available in both diffusion and internal pump models, MicroMax simultaneously monitors 1 to 4 gases (5 with Combo-Tax™). The popular internal pump models allow for easy pre-testing in confined spaces and provide almost instantaneous readings of gas concentrations. The MicroMax has many preset and field selectable alarms. Both audible and visual alarms warn the user if the oxygen levels are either too low or enriched, and when combustible gas or toxic gas levels are too high. The toxic gas alarms can be easily adjusted in the field from immediate to TWA. Alarms will also activate in case of sensor failure, low battery voltage, pump blockage or low air flow. Lumidor's unique microprocessor design allows for self diagnostics with each start up. MicroMax internally data logs individual channel alarms, TWA averaging and peak information. With a push of the "Mode" button, review information as well as check battery voltage and elapsed time. This information is available for display and documentation by downloading to a standard PC when the data logging option is purchased. Calibration is also easy - simply place in calibration "Mode", introduce calibration gas, wait two minutes and calibration is complete!



The MicroMax includes: a carrying case with shoulder strap, a rechargeable NiCad battery pack with an overnight AC charger, an alkaline battery holder, a 10' sampling hose with water trap and a particulate filter.

Additional accessories available include: a data logging version (includes software and serial cable), 4-hour quick charger, 5-unit bank charger, DC-to-DC vehicle charging adapter, aluminum or fiberglass scorch probes, high-impact carrying case, portable printer (for data logging version), calibration gases, "Bump test" gases, confined space kits, and a class 2 version for high dust or water resistant applications.

MicroMAX

Part #	Description
MAX-4AP	Monitor, MicroMax, Pump, Combustible, Oxygen, Carbon Monoxide & Hydrogen Sulfide
MAX-4BP	Monitor, MicroMax, Pump, Combustible, Oxygen, Hydrogen Sulfide & Sulfur Dioxide
MAX-4CP	Monitor, MicroMax, Pump, Combustible, Oxygen, Carbon Monoxide & Sulfur Dioxide
MAX-3DP	Monitor, MicroMax, Pump, Combustible, Oxygen, & Carbon Monoxide
MAX-3EP	Monitor, MicroMax, Pump, Combustible, Oxygen, & Hydrogen Sulfide
MAX-3FP	Monitor, MicroMax, Pump, Combustible, Oxygen, & Sulfur Dioxide
MAX-2GP	Monitor, MicroMax, Pump, Combustible, Oxygen

Ask about Other Variations Available



MAX VALUE CALIBRATION KITS

MAX VALUE Kits are the comprehensive and cost effective way to fulfill your gas detection needs. These kits are supplied with either calibration gas or alarm “bump” check gas, a tough, water resistant carrying case, and an operational/maintenance video. A variety of kit combinations are available. The three most common kit types are given below.



MAXKIT- 1

This kit includes: “Four-In-One” calibration gas cylinder (58 liter), a regulator and tubing, an operational/maintenance video, and a watertight/impact resistant carrying case.

MAXKIT- 1 Mini.

This kit includes: “Four-In-One” calibration gas cylinder (15 liter), a regulator and tubing, an operational/maintenance video, and a water and impact resistant carrying case.

MAXKIT-5

This kit includes: Alarm “Bump” check gas, an operational/maintenance video, and a water and impact resistant carrying case.

Part #	Description
MAX-KIT1	Kit, Four-In-One Calibration Gas Cylinder (58 Liter), Regulator, Video & Case
MAX-KIT-1MINI	Kit, Four-In-One Calibration Gas Cylinder (15 Liter), Regulator, Video & Case
MAXKIT-5	Kit, Alarm “Bump” Check Gas, Video & Case

UniMAX PERSONAL SINGLE GAS DETECTOR

The UniMax is the only single gas detector you’ll ever need. With Lumidor’s Lifetime Warranty and state-of-the-art sensors and electronics, the UniMax ensures both worker safety and simple operation. It is affordable, reliable, and easy to use. Features include: simple calibration, interchangeable plug-in sensors, multiple alarm indicators including an optional vibrating alarm and user programmable alarms, low battery warning, lightweight, rugged construction and a lifetime Warranty. It is RFI/EMI resistant, UL classified.



Part #	Description
UNI-X0201V	Unimax, Monitor, Personal, Single-Gas, Oxygen, 19.5% low & 23% High Alarms, with Vibrator
UNI-XC008N	Unimax, Monitor, Personal, Single-Gas, Carbon Monoxide, 25ppm Alarm (CA OSHA)
UNI-XC008V	Unimax, Monitor, Personal, Single-Gas, Carbon Monoxide, 25ppm Alarm (CA OSHA), with Vibrator
UNI-XC009N	Unimax, Monitor, Personal, Single-Gas, Carbon Monoxide, 35ppm Alarm
UNI-XC009V	Unimax, Monitor, Personal, Single-Gas, Carbon Monoxide, 35ppm Alarm, with Vibrator
UNI-H2S07N	Unimax, Monitor, Personal, Single-Gas, Hydrogen Sulfide, 10ppm Alarm
UNI-H2S07V	Unimax, Monitor, Personal, Single-Gas, Hydrogen Sulfide, 10ppm Alarm, with Vibrator
UNI-NH308N	Unimax, Monitor, Personal, Single-Gas, Ammonia, 25ppm Alarm
UNI-CL204N	Unimax, Monitor, Personal, Single-Gas, Chlorine, 0.5ppm Alarm
UNI-CLO03N	Unimax, Monitor, Personal, Single-Gas, Chlorine Dioxide, 0.1ppm Alarm
UNI-SO205N	Unimax, Monitor, Personal, Single-Gas, Sulfur Dioxide, 2.0ppm Alarm
UNI-PH310N	Unimax, Monitor, Personal, Single-Gas, Phosphine, 0.3ppm Alarm
UNI-NO206N	Unimax, Monitor, Personal, Single-Gas, Nitrogen Dioxide, 3.0ppm Alarm

ToxiBEE PERSONAL GAS ALARM

The ToxiBee disposable personal single gas alarm is available for H₂S and CO detection. Although maintenance free for its two-year life, ToxiBee can be calibrated in the field when verification is required. It’s the only unit of its kind with this feature. The self-test button allows the user to test the unit at any time. This unique feature ensures that the circuitry, audible and visual alarms and LCD indicators are functioning correctly. The ToxiBee is one of the lightest units available. Its compact microprocessor-based electronics provide the most stable and reliable reading over a wide temperature range. ToxiBee is designed, tested and manufactured under strict ISO 9001 quality systems, is UL and ULC classified intrinsically safe and backed by Lumidor’s 2 year Lifetime Warranty.



FEATURES

- Maintenance free
- Self-test diagnostics
- Simple calibration (if required)
- Unique incremental PPM display
- 2-year continuous operation
- Affordable, reliable and disposable
- RFI/EMI resistant
- Multiple alarm indicators
- No battery replacement required
- Low battery warning
- UL and ULC classified
- Lightweight, rugged construction

Part #	Description	Gas	Alarm Setpoint	Gas Ranges
TOXI-H2S07	ToxiBEE personal gas alarm	Hydrogen Sulfide	10 PPM	0 - 500 PPM
TOXI-XC008	ToxiBEE personal gas alarm	Carbon Monoxide*	25 PPM	0 - 1000 PPM
TOXI-XC009	ToxiBEE personal gas alarm	Carbon Monoxide	35 PPM	0 - 1000 PPM

* California



The Professional Cleaner’s One-Step Source
for Equipment, Chemicals, Parts, Accessories,
Service, Training and Business Support.



Instrumentation



FiveStar® Alarm

(The new standard for rugged, simple, and fast gas detection)

The FiveStar Alarm provides the flexibility to meet your gas detection needs, yet is incredibly simple to use. The durable, high-impact case makes it long-lasting, while the advanced ergonomic design and software reduce worker load and simplify operation. These features mean less time spent training and less time out of service. Over its life, the FiveStar Alarm's ease of use, safety features, and long-term money savings combine to provide the best in gas detection available today.

The FiveStar Alarm's simplicity is obvious from the start:

- Three well-marked, easy-to-use keys.
- Display faces user.
- High level of RFI protection.
- Flexible smart sensors.
- Weatherproof-AP54-rated.

The FiveStar Alarm's advanced software features mean safer operation:

- Limits on sensor zeroing.
- Limits on one-button calibration.
- User acknowledges configuration changes.
- Data recording is standard.

The FiveStar Alarm saves money:

- Unbeatable warranty and service.
- Long-life combustible sensor.
- One-button calibration saves training and gas.
- 5-gas capability means one detector can do the job of two.
- Battery "gas gauge" reduces down time.
- 20-hour NiMH battery option means one battery can do the job of two.

Gas sensors available--you can order the FiveStar Alarm with sensors to detect:

- Combustible gas (0-100% LEL or 0-5% methane)
- Oxygen (0-25%) and up to **three** of the following gases
 - Carbon monoxide 0-2000 ppm
 - Hydrogen sulfide 0-500 ppm
 - Nitric oxide 0-500 ppm
 - Nitrogen dioxide 0-500 ppm
 - Sulfur dioxide 0-500 ppm
 - Phosphine 0-5 ppm
 - Chlorine 0-20 ppm
 - Chlorine dioxide 0-5 ppm

More gas detection capabilities are continually introduced. Call for availability of other gas detection capabilities. Some configuration limitations apply.

Ordering Information

FiveStar Alarms can be ordered in one of two convenient ways. Either select from the highly popular kit combinations below or refer to MSA's highly effective custom-ordering process, "Assemble-to-Order."

Five Star Alarm Kit Options													Part No.	
	LEL	O ₂	CO	H ₂ S	NiCd Battery	AC Charger	Fast Charger	Calibration Cap	Pulsecheck Pump	10 ft. Line	1 ft. Probe	Leather Jacket		Carrying Case
Deluxe 4-gas	*	*	*	*	*	*	*	*	*	*	*	*	*	10018002
Deluxe 3-gas, CO	*	*	*	*	*	*	*	*	*	*	*	*	*	10018003
Deluxe 3-gas, H ₂ S	*	*	*	*	*	*	*	*	*	*	*	*	*	10018004
Industrial 4-gas	*	*	*	*	*	*	*	*	*	*	*	*	*	10018005
Industrial 3-gas, CO	*	*	*	*	*	*	*	*	*	*	*	*	*	10018006
Industrial 3-gas, H ₂ S	*	*	*	*	*	*	*	*	*	*	*	*	*	10018007
Economy 4-gas	*	*	*	*	*	*	*	*	*	*	*	*	*	10018008
Economy 3-gas, CO	*	*	*	*	*	*	*	*	*	*	*	*	*	10018009
Economy 3-gas, H ₂ S	*	*	*	*	*	*	*	*	*	*	*	*	*	10018030

Assemble-to-Order (ATO) System: You Make the Choices

The ATO System makes it easy to "Custom Order" the FiveStar Alarm, configured exactly the way you want it. To obtain a copy of the ATO System for the FiveStar Alarm, request Bulletin NO. 0816-07-MC.





ORION Multigas Detector

You've always trusted the MSA name for the ultimate in quality, performance and support. Now, MSA introduces the best combination of features and low price available on the market.

Once again MSA delivers!

The Orion Multigas Detector is a low-cost, reliable and easy-to-use portable instrument for detecting the presence of O₂, H₂S, CO and combustible gas. It will stand up to the toughest environments. A charger and optional built-in sampling pump are included in the price.

Introducing the best combination features and low price available on the market.

- One-Button Calibration
- Large, Easy-to-Read Display
- Built-in Pump
- Carbon-Filled-Nylon Case
- Link™ Software
- Tough, Durable Construction
- Long-Life Battery
- Durable Sensors
- TIM® System Compatibility

Orion Multigas Detector Kits	LEL	O ₂	CO	H ₂ S	NIMH Battery + Charger	Alkaline Battery	Calibration Cap	Internal Pump	10 ft. Line	1 ft Probe	Orange Cordura Case	Calibration Kit	Black Economy Case	Boot	Part No.
Deluxe 4-gas	*	*	*	*	*		*	*	*	*	*	*	*	*	10025932
Deluxe 3-gas H ₂ S	*	*		*	*		*	*	*	*	*	*	*	*	10025935
Deluxe 3-gas CO	*	*	*		*		*	*	*	*	*	*	*	*	10025938
Standard 4-gas	*	*	*	*	*		*	*	*	*			*	*	10025931
Standard 3-gas H ₂ S	*	*		*	*		*	*	*	*			*	*	10025934
Standard 3-gas CO	*	*	*		*		*	*	*	*			*	*	10025937
Economy 4-gas	*	*	*	*		*	*						*	*	10025930
Economy 3-gas H ₂ S	*	*		*		*	*						*	*	10025933
Economy 3-gas CO	*	*	*			*	*						*	*	10025936





Passport® PID II Monitor

Passport® PID II Organic Vapor Monitor

Passport PID II Organic Vapor Monitor

The Passport PID Organic Vapor Monitor is a convenient, portable instrument for detecting low concentrations of volatile organic compounds (VOCs). The passport PID II Monitor's compact design supports a variety of monitoring applications.

Used primarily in connection with hazardous materials spills, soil remediation, and underground tank leakage, the Passport PID II Monitor can also be used for emissions monitoring and general leak detection.

Ordering Information

Passport PID II Kits

Part #	Description
711401	Kit includes Passport PID II, NiCd battery pack, 110V charger, 10-ft. coiled Teflon sampling line, 1-ft. probe, PVC case
711402	Kit includes Passport PID II, alkaline battery pack, pistol grip, 8-in. probe, PVC case

Common Compounds Detectable with Passport PID II Monitor

Acetone	Benzene
Chlorobenzene	Cyclohexane
Heptane	Hexane
Propylene	Phosphine
Toluene	Trichloroethane
Methyl Isobutyl Ketone (MIBK)	
Methyl Tetrabutyl Ether (MTBE)	
Octane	
Many others	

Approvals

MET (an OSHA-NRTL); Class I, Division 1, Groups A, B, C, and D; Class II, Division 2, Groups E, F and G; and Class III, Division 1 and 2.

Assemble-to-Order (ATO) System: You Make the Choices

The ATO System makes it easy to "Custom Order" the Passport PID II Organic Vapor Monitor, configured exactly the way you want it. You can choose from an extensive line of base instrument components and accessories. To obtain a copy of the Passport PID II Organic Vapor Monitor ATO, request Bulletin NO. 0816-04-MC.



Cricket® Personal Alarm

["Disposable" nature of Cricket Alarm eliminates battery and sensor changes]

The Cricket series of personal alarms are miniature practically maintenance-free instruments designed to provide users with an inexpensive yet dependable way to monitor for oxygen, CO or H₂S. Cricket devices feature a three-volt lithium battery and a high performance sensor—both of which provide two years of continuous operation for CO and H₂S versions, one year for the O₂ version.

Offering a multitude of applications, Cricket Personal Alarms are well-suited for use in such potentially hazardous environments as confined spaces, oil refineries, pulp and paper mills, and other industries where personal monitoring is necessary.

Approvals

MET (an OSHA-NRTL); Class I, Division 1, Groups A, B, C, and D; Class II, Division 1, Groups E, F and G; and Class II. For more complete information, see Data Sheet 08-00-14.

Ordering Information

Cricket® Personal Alarm

Test Gas Check Kit

Test Gas Station only 804626



Instruments

Part No.	w/Test Station	Gas	Lo Alarm	Hi Alarm	Test Gas Cylinder	
					Part No.	Conc.
804746	no	CO	35 ppm	400 ppm	806255	400 ppm
805639	yes	CO	35	400	806255	400 ppm
812714	no	CO	50ppm	200 ppm	809243	200 ppm
809956	no	CO	150 ppm	200 ppm	809243	200 ppm
812501	yes	CO	150	200	809243	200 ppm
804745	no	H ₂ S	5 ppm	15 ppm	806253	15 ppm
805638	yes	H ₂ S	5	15	806253	15 ppm
809186	no	H ₂ S	10 ppm	15 ppm	806253	15 ppm
812500	yes	H ₂ S	10	15	806253	15 ppm



Escort ELF® Sampling Pump



Escort ELF® Sampling Pumps

The patented Escort ELF Sampling Pump can be used for personal and area sampling. The state-of-the-art electronic laminar flow sensor, consisting of a laminar flow element and pressure sensor, provides constant flow (volume) control, with $\pm 2.5\%$ regulation of flow rate (from 1 to 3 lpm) and automatic compensation for changes in battery voltage, temperature, altitude, and sample load. An internal secondary standard calibrates the pump continuously and need to be checked against a primary standard only once a month (or every 200 hours for coal mine dust sampling).

Approvals

Escort ELF Sampling Pumps are UL approved as intrinsically safe for use in hazardous locations—Class 1, Group A, B, C, D; Class II Groups E, F, and G; and Class III, Division I locations. NIOSH-certified for coal mine dust sampling (TC-74-030). MSHA certified as intrinsically safe for underground use (Approval No. 2G-3924-1).

Ordering Information

Escort ELF Kits

Part #	Description
805559	Escort ELF Pump with flow fault indicator, 110V single-unit charger, Gemini® Twin port Sampler, and standard packaging
805560	Escort ELF Pump with flow fault indicator, 110V single-unit charger, sampling line, and standard packaging

Replacement Parts

Part #	Description
497702	Battery Pack with O-ring
802897	One Replacement Inlet Water Stop Filter
802922	Escort Pump Overhaul Kit—common components for routine maintenance
808935	Inlet Dust Filter (pkg. of 5)

Note: Elf Pump Kits can be ordered in 5 unit kits. Reference A-T-O form #0810-33-MC

Escort® LC Sampling Pump

Escort® LC Sampling Pumps

The Escort LC Sampling Pump can be used with a variety of personal and area sampling devices to collect such airborne contaminants as asbestos fibers, toxic gases, vapors, particulates, fumes, and mists. It can also be used to sample silica dust, coal dust, and organic vapors.

The Escort pump is exceptionally compact, lightweight, and quiet in operation. Engineered for use in “hostile” environments, the unit can be sprayed with water while it is operating without being damaged.

Approvals

Escort LC Sampling Pumps are UL approved as intrinsically safe for use in hazardous locations—Class 1, Group A, B, C, D; Class II Groups E, F, and G; and Class III, Division I locations.

Ordering Information

Escort LC Kit

Part #	Description
711400	Escort LC Pump with 110V single-unit charger, sampling line and standard packaging



ANTI-VIBRATION GLOVES

Made of white top grain leather, these gloves are designed with an open thumb for easy gripping and include NBR palm inserts for superior shock absorption.



ALLEGRO
INDUSTRIALS

Part#	Description	Sizes
7310	Anti-Vib	S - XL

FLEXRIST®

The comfortable all around support of Neoprene that can be worn on either the right or left hand.



ALLEGRO
INDUSTRIALS

Part#	Description	Sizes
7111	FLEXRIST®	XS - XL

A-400 WRIST SUPPORT

Vinyl covered steel spring limits flexion (downward movement) and provides excellent support. The patented full wrapping strap holds the support in place.



ALLEGRO
INDUSTRIALS

Part#	Description	Sizes
7312	A-400 Wrist Support	XS - XL

A-410 WRIST SUPPORT

Same great features as the A-400 with the added support of two patented wrap-around straps that limit upward and downward movement.



ALLEGRO
INDUSTRIALS

Part#	Description	Sizes
7314	A-410 Wrist Support	XS - XL

DELUXE ANTI-VIBRATION GLOVES

Our Deluxe Anti-Vib Gloves offer unique Nitrile Butyl Rubber (NBR) palm inserts that absorb and dampen shock. They are made of grained cowhide for long wear and include a heavy-duty wrist strap for added wrist protection.



ALLEGRO
INDUSTRIALS

Part#	Description	Sizes
7320	Deluxe Anti-Vibration Glove	S - XL

DUAL-FLEX™

For firm support, the DUAL-FLEX contains four stays on the front and back of the wrist to limit flexion (downward) and extension (upward) movement and encourage neutral wrist position. The straps wrap completely around the wrist for added support. Easy to put on, it is lined to keep hands dry and fits both right and left hands.



ALLEGRO
INDUSTRIALS

Part#	Description	Sizes
7212	Dual-Flex™	XS - XL

TENNIS ELBOW SUPPORT

For repetitive elbow movement, this support offers a unique 2" wide strap design that directs pressure to the forearm and eases strain on the elbow.

Measure around the largest part of the forearm about 2 1/2" below the elbow.



ALLEGRO
INDUSTRIALS

Part#	Description	Sizes
7107	Tennis Elbow Support	S - XL

**IF THERE IS AN
ALLEGRO
ITEM THAT YOU NEED BUT
YOU DON'T SEE IT SHOWN HERE
PLEASE ASK OUR
EXPERIENCED SALES STAFF
FOR MORE INFORMATION**

SOFTKNEE



A tough blend of cloth and foam make these pads extra comfortable and easy to wear in non-abrasive environments. They slip on and off quickly without straps or buckel attachments. Easy to wear over or under trousers, they are lightweight and durable. (pair)



STANDARD KNEE PADS

These knee pads are simply made of contoured rubber. The one-piece molded construction is made for long lasting wear. They adjust with a Velcro® strap for a secure fit. (Pair)



Part #	Description	Size
7105	Softknee	OS

Part #	Description	Size
7101	Knee Pads, Standard	OS

MAXKNEE



These knee pads are tough and comfortable. The MAXKNEE features an outside ABS knee cap that resists abrasion, and full padding on the inside for maximum comfort. Two fully adjustable Velcro® straps offer a custom fit. (Pair). For fast easy attachment, the MAXKNEE is available with a unique quick release buckle that eliminates the need for readjusting the straps and is called the QUICKMAX.



DELUXE QUICKFLEX

Offering the most protection available, our Deluxe QuickFlex is a completely unique knee pad. The large, 3/4" thick pad has a hinge design that provides protection and ease of movement above and below the cap, and a wrap-around design for greater side protection. The large soft rubber cap conforms to the shape of the knee for maximum protection. The double strap system uses 1 1/2" straps with the deluxe quick release buckles, and allows for easy adjustment and a snug fit while ensuring greater stability and side protection. (pair)



Part #	Description	Size
7102	Knee Pads, Maxknee	OS
7102Q	Knee Pads, QuickMax with quick release buckle	OS

Part #	Description	Size
6990	Deluxe QuickFlex	OS

BLACK FLEXKNEE



The favored pad of government and municipal workers, the black FlexKnee offers the same features as our popular FlexKnee, including Velcro straps. (pair)



NON-MARKING FLEXKNEE

A non-marking polyurethane cap is used on our FlexKnee to allow workers to move around the work area without marking or damaging a delicate surface such as tiling. Velcro straps allow for a custom fit and make donning quick and easy. (pair)



Part #	Description	Size
7103-02	Black Flexknee	OS

Part #	Description	Size
7103-01	Non-Marking Flexknee	OS

CALL FOR SPECIAL BULK PRICING

STRONG FLEXIBLE SUPPORTS BY



ESS

STANDARD ELBOW SUPPORT

ESS is a standard elbow support that is terry-lined vented neoprene with nylon outer shell. Retains heat without moisture build up. Washable.



KSC

CLOSED PATELLA KNEE SUPPORT

The KSC closed patella knee support is terry-lined vented neoprene with nylon outer shell. Retains heat without moisture build up. Washable.

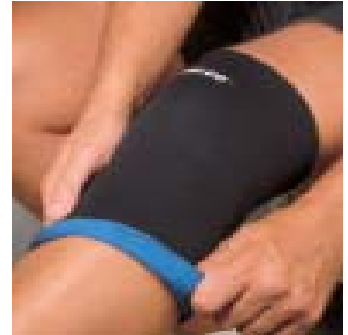

VES

STANDARD ELASTIC BELT



Elastic, power net body for lightweight, comfortable support. Size adjusts easily with two stage hook & loop closure system. Includes quick-release, detachable suspenders and four rubberized back support stays help keep belt in place. Washable.

VEH

HEAVY-DUTY ELASTIC BELT



Heavy-duty, breathable elastic body with five rubberized back support stays to help keep belt in place. Size adjusts easily with two stage hook & loop closure system. Quick-release, detachable suspenders for safety. Washable.

Part #	Description	Size
ESS	Valeo® Standard Elbow Support, black, sold individually	S -XL
KSC	Valeo® Closed Patella Knee Support, black, sold individually	S -XL
VEH	Valeo® Heavy-Duty Elastic belt, 9" width, black	XS - 2XL
VES	Valeo® Standard Elastic belt, 8" width, black	S - XL



STRONG FLEXIBLE SUPPORTS BY

GMFS

FULL-FINGER MECHANIC'S GLOVE



Features a heat-resistant double-layered synthetic leather palm with double stitching for long life. Stretch-knit padded back with reinforced knuckles and fingertips for additional protection. Elastic cuff with hook & loop closure. Machine wash and dry.

GLAS

HALF-FINGER ANTI-VIBRATION GLOVE



Sorbothane® padding in the palm, thumb and index finger, which reduces shock. Made of leather with a breathable nylon mesh back and an adjustable hook & loop closure for a non-restrictive fit. Machine wash and dry.

GMLS

HALF-FINGER MESH BACK GLOVES



Double leather palm with a cotton mesh back and tab closure. Die cut to ensure consistent fit and quality. These gloves are comfortable and economically priced.

GLAW

WRAP HALF-FINGER ANTI-VIBRATION GLOVES



Sorbothane® padding in the palm, thumb and index finger, which reduces shock. Made of leather with a breathable nylon mesh back. Features an elastic wrist wrap with a non-conductive support pad and an adjustable hook & loop closure for a non-restrictive fit. Machine wash and dry.

WSS

WRAP-AROUND WRIST SUPPORT



Ambidextrous wrist support made of terry-lined vented neoprene with a nylon outer shell. Hook & loop closure for long-wearing comfort. Washable.



**OFFERS INNOVATIVE
DESIGN AND PROVEN
PERFORMANCE**

Part #	Description	Size
GMFS	Valeo® Full-finger Mechanic's gloves, black, sold in pairs,	XS - 2XL
GLAS	Valeo® Half-finger Anti-vibration gloves, black, sold individually or in pairs	XS - 2XL
GMLS	Valeo® Half-finger Mesh Back gloves, black, sold in pairs	XS - 2XL
GLAW	Valeo® Wrap Half-finger Anti-vibration gloves, black, sold individually or in pairs	XS - 2XL
WSS	Valeo® Wrap Around Wrist Support, black, sold individually	OS

1st AID KITS BY PowerPlus CORP.



#2025E

25 PERSON FIRST AID KIT

CONTENTS

50	Adhesive Strips
1	First Aid Instructions
1	Adhesive Tape Roll
1	First Aid Cream
10	Wound Wipes
1	Gauze Bandage
3	Ammonia Inhalants
10	Gauze Pads
12	Aspirin Tablets
1	Cold Pack
2	Gloves, Latex
1	Combine Dressing
1	Scissors
1	Cotton, 0.5 oz.
1	Triangular Bandage
1	Tweezers

#2050E

50 PERSON FIRST AID KIT

CONTENTS

100	Adhesive Strips
1	First Aid Instructions
1	Adhesive Tape Roll
2	First Aid Cream
20	Wound Wipes
2	Gauze Bandage, 2"
1	Gauze Bandage, 4"
3	Ammonia Inhalants
20	Aspirin Tablets
20	Gauze Pads
1	Cold Pack
1	Combine Dressing
4	Gloves, Latex
1	Cotton 0.5 oz.
1	Scissors
1	Elastic Bandage, 2"
1	Triangular Bandage
1	Tweezers

#2100E

100 PERSON FIRST AID STATION

CONTENTS

200	Adhesive Strips
1	First Aid Instructions
30	Adhesive Strips, Fingertip
2	First Aid Cream
30	Adhesive Strips, Knuckle
4	Gauze Bandage, 2"
4	Gauze Bandage, 4"
6	Adhesive Strips, Xtra-Large
1	Adhesive Tape Roll
25	Gauze Pads, 2" x 2"
20	Alcohol Wound Wipes
25	Gauze Pads, 3" x 3"
10	Ammonia Inhalants
25	Gauze Pads, 4" x 4"
100	Aspirin Tablets
4	Gloves, Latex
1	Blanket, Aluminized, 60" x 84"
6	Poison Plant Relief, 1/8 oz. Foil Packs
2	Cold Packs
12	Povidone Iodine Ointment, 0.5 gm
2	Combine Dressings
1	Scissors
2	Cotton 0.5 oz.
10	Sting Relief Towelettes
1	Elastic Bandage, 2"
1	Tourniquet
2	Eye Irrigate Solution, 1 oz.
2	Triangular Bandage
8	Eye Pads with Strips
1	Tweezers

Call and Ask One of Our
Team Members

About Customized First Aid Kits.
If you don't see the 1st Aid Kit that
fits your needs, they can help you
find one that does!



Swift First Aid

Part #	Description	Size
16-1615	Pain Stoppers, Extra Strength	100/bx
16-1581	Aypanal (non-aspirin) Pain reliever	100/bx
16-1583	Aypanal (non-aspirin) Pain reliever	250/bx
16-1986	Aypanal Extra Strength	100/bx
16-1512	Aspirin	250 tablets
16-15450	Advil, Analgesic	100-2's/bx
16-44910	Tylenol Extra-Strength Caplets	50-2's/bx
17-1545	Miralac Antacid, Antacid, Sugar Free	100 tablets/bx
21-2100	Cor-A-Fed Plus, Multi-Symptom, Colds	100 tablets/bx
24-0704	Swifteeze Eye Wash, Sterile isotonic solution used to flush particles and irritants from eye	4oz.
15-4818	Alcohol Wipes, Individually sealed	50/bx
15-CL016	Betadine, Surgical Scrub (no pump)	16 oz.
23-2124	Triple Antibiotic Ointment	20/bx
15-0969	Hydrogen Peroxide, Local Antiseptics	16 oz.
15-0935	Alcohol 70%	16oz.
20-1005	Burn Spray, Medicated, Helps relieve pain from minor burns	3oz. can
10-0530	Medi-Rip 3" x 5yd.	ea.
02-3144	Adhesive Tapes, 1/2" x 10yd. Tape	ea.
01-0045	Plastic Bandages, 3/4" x 3" Strips	100/bx
01-0050	Plastic Bandages, 1" x 3" Strips	100/bx
01-6459	Woven Bandages, 1" x 3" Strips	100/bx
01-2315	Woven Bandages, 1" x 3" Strips	50/bx
01-3940	Woven Bandages, Knuckle	40/bx
01-1350	Woven Bandages, FingerTip "T"	40/bx
01-1325	Woven Bandages, FingerTip "8"	25/bx
01-1975	Wound Care, Butterfly Closures, med.	100/bx
06-1910	BloodStopper Trauma Dressing, many uses: Fractures, Burns, Heavy External Bleeding, Surface Wounds and Abrasions	ea.

BODY FLUID CLEAN UP KIT w/CPR MASK #35-P10BBK

- 1 Each of the Following: Face Mask w/Eyeshield, Pick-up Scoop w/Scraper, Shoe Covers & Cap, Surface Cleaning Wipe, Liquid Treatment System, Gown, CPR Mask
- 2 Each of the Following: Red Bio-Hazard Waste Bags, Disposable Towel & Wipes, Latex Gloves



JUNKIN STRETCHERS

Series 300 Stretchers are the most efficient and practical products of their kind on the market. Made of steel, all welded rigid construction which does not rely on injured person to attain form or rigidity. They are light in weight and ample in size.

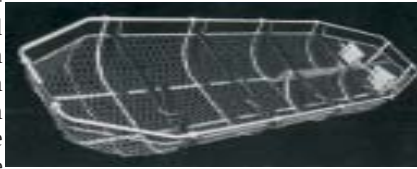

Light Weight Basket Type Stretcher SAF-300

This stretcher features nylon web straps at chest, abdomen, thigh, and calf. Adjustable footrests for vertical lifting. Frame is $\frac{5}{8}$ " steel tubing: cross braces and runners $\frac{3}{16}$ " x $\frac{3}{4}$ " flat steel. Basket is 18 gauge, 1" hexagon mesh netting.

DIMENSIONS: 80" L; 8" H; Chest: 22" W; Abdomen 22" W; Thigh 21" W; Calf 20" W.

CARTON SIZE: 83" x 8" x 24".

SHIPPING WEIGHT: 31 lbs.

Stretcher Bridle Sling SAF300-X

The SAF-300-X Stretcher Bridle Sling provides horizontal or vertical sling capacity of up to 2,000 lbs. Made of 1" nylon webbing resistant to moisture, fungus and rot with forged snap hooks and 3" ID forged steel suspension ring.

Patient Restrainer Strap SAF-300-4

Standard length 5'. Extra length available.

BREAK-AWAY PLASTIC STRETCHER SAF-200B

Designed to rescue injured persons from locations where lengthy foot travel is mandatory.

Yellow high-density polyethylene shell, supported by a stainless steel outer rail, permanently attached with stainless steel semi-tubular rivets.



Features molded runners,

fully exposed outer rail, non-absorbent foam pad secured to stretcher and four patient restraint straps. The stretcher breaks into two halves which can be back-packed to the point of rescue and assembled in seconds. Positive locking quick-release pins secure two halves together. Four straps are standard. Ideal for unusually rugged rescue situations.

DIMENSIONS: 84" L; 24" W; 7" Depth.

LOAD CAPACITY: 1200 lbs.

SHIPPING WEIGHT: 32 lbs.

Part #	Description
SAF-300	Stretcher, Basket Type, Light Weight
SAF-300-X	Stretcher Bride Sling
SAF-300-4	Patient Restrainer Strap
SAF-200B	Stretcher, Break-Away, Plastic

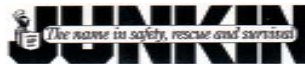

GOJO® ORIGINAL FORMULA HAND CLEANER - 1109

This classic creme-type favorite was our first formula developed in the 1940s. It is our original formula for tough on the job grime, grease and soils. Lanolin and soothing emollients condition and protect hard-working hands against drying, chapping and cracking. We recommend it for asphalt, carbon, diesel oil, graphite, grease, grime, sludge, stain, varnish, resin glues and tar.



CREME CARTRIDGE DISPENSER - 1204

Our durable, popular dispenser for GOJO Brand heavy-duty hand cleaners that come in 4.5 lbs. plastic cartridges. Creme Cartridge Dispenser Holds 4.5 lbs. plastic cartridges: 1115 and 1135



1204

GOJO® NATURAL ORANGE™ HAND CLEANER WITH PUMICE

A hand cleaner with fine Italian pumice for moderate grease and medium soils packaged in our award-winning 14 fl. oz. GRIPPIT® bottle with a convenient nail brush on the side. Pumice is a naturally-occurring mineral that helps remove stubborn soils from your skin. We recommend GOJO® NATURAL* ORANGE™ for adhesive, asphalt, carbon, cement, graphite, grease, grime, paint, printer's ink, putty, shellac, stain and tar. It can be used with or without water. Perfect in your garage, shed or workroom. GRIPPIT® bottles with nail brush included. *Petroleum-free citrus ingredient. (Not Shown)

Part #	Description
1109	GOJO® Original Formula Hand Cleaner, 18 oz. plastic cartridge
1115	GOJO® Original Formula Hand Cleaner, 4.5 lb. plastic cartridge for dispenser or stand alone
1135	GOJO® Fine Italian PUMICE Hand Cleaner, 4.5 lb. plastic cartridge for dispenser or stand alone
0945	GOJO® Natural Orange Hand Cleaner, 1 Gallon with Pump and GRIPPIT Hand & Nail Brush
1204	Cream Cartridge Dispenser for 1135 & 1115

EYE-LERT[®] EMERGENCY EYEWASH



EYE-LERT[®] EMERGENCY BUFFERED EYEWASH AND BODY FLUSH STATIONS are self-contained, easily installed systems that provide workers with immediate eye or body flushing in the event of an accident involving acids, caustics or other water soluble irritants. Eye-Lert Buffered Eyewash is a sterile, soothing, normal saline wash. Use in areas where accidents are most likely to occur, such as near battery storage areas, on flight lines, in plating facilities, and chemical processing operations. Stations are equipped with both double-back tape and screw holes for easy mounting. Bottle caps are tamper evident, guaranteeing sterility. The pull-out-bottle design is ideal for quick removal in emergency situations.

NORTH EMERGENCY BODY FLUSH STATIONS provide two 32 oz. bottles of a buffered, sterile, isotonic saline solution on an easily mounted, highly visible backplate.



NORTH BODY FLUSH STATIONS

Part #	Description
12-60-33	North Safety, Emergency Eyewash Station, complete, sterile, 16oz.
12-60-34	North Safety, Emergency Eyewash Replacement cap, sterile, 16oz.
12-60-32	North Safety, Emergency Eyewash Station, complete sterile, 32oz.
12-60-37	North Safety, Emergency Eyewash Replacement cap, sterile, 32oz.
12-60-42	North Safety, Emergency Eyewash Double Station, complete, two 32oz. bottles
12-60-38	North Safety, Body Flush Station, Complete, 2 - 32oz. Bottles
12-60-39	North Safety, Body Flush Replacement Bottle, 32oz.

PURE FLOW[®] 1000 EMERGENCY EYEWASH

fend-all company

Pure Flow dispenses a comfortable, contaminant-free, pH-balanced saline solution as recommend by ANSI Z358.1-1998 standard. It reduces the risks and maintenance hassles of using stagnant solutions, such as tap water and bacteriostatic/water mixes. And its new water pressure balancing system provides a constant flow rate for the entire 15-minute flush. All of these features make Fendall's PURE FLOW[®] 1000 Emergency Eyewash Station the safest and most reliable eyewash device available.



The replaceable delivery modules are comprised of an Eyesaline[®] cartridges, delivery tubes, and nozzle assemblies, all of which function as one integral unit. Because the unit is sealed until activated, safety and reliability are guaranteed. This is superior to conventional portable and plumbed units, both of which can flush with contaminated stagnant water or solution that will infect the entire eyewash station and allow harmful bacteria, viruses, algae and fungi to cling to the interior of the eyewash station.

Because the Eyesaline cartridges last 24 months unless activated (4 to 8 times longer than other self-contained eyewash station's solution) you'll save money on refills and labor. No special plumbing is needed, and the system mounts easily with one bracket. Weekly flushing or monthly or semi-annual solution changing is not required. When your system does need servicing, it takes five minutes or less to replace the solution delivery modules—compared to a half hour or longer to drain, clean, and refill self-contained units.

This unit captures it's own waste fluid and a warning service immediately sign appears when unit is discharged. The optional 1060 Universal Cart (pictured with PURE FLOW[®] 1000) provides portability for gravity-fed, self-contained, emergency eyewash stations including Fendall PURE FLOW[®] 1000, Fendall Porta Stream Units and other brands. It features sturdy steel construction, a durable finish, and simple quick assembly. The classic hand-truck design provides easy maneuverability with a wide base for stability, and large semi-pneumatic wheels. A 28 gallon waste container that securely fits onto the cart for those units needing waste collection is also available (not pictured and sold separately part #1061).



Part #	Description
1000	Emergency Eyewash, PUREFLOW [®] 1000, without Cartridges
1050	Fluid Cartridges for PUREFLOW [®] 1000
1060	Mobile Cart for PUREFLOW [®] 1000



7360BT EYE/FACE WASH

The 7360BT EYE/FACE WASH has a 11" receptor made of stainless steel with #7 bright finish on exterior. Twin Feather-Flo* patented ABS plastic eye/face wash heads in Safety Green with integral flip top dust covers that protect heads and automatically release with water pressure. A stainless steel push flag operates a stay open chrome plated brass ball valve that is equipped with a stainless steel ball and stem. Universal language emergency sign included.



Shown here with optional 9101 dust cover

Part #	Description
7360BT	Eye/Face Wash, Stainless Steel Bowl, P-Trap

7500 PORTABLE GRAVITY OPERATED EYEWASH

The 7500 is a portable gravity operated eyewash with 16 gallon capacity tank and is made of FDA high-density polyethylene material. It has single top handle for easy carrying when empty and dual double-wide integral side handles to facilitate two person handling when filled. It features a threaded cap and wide fill opening for easy filling, inspection and cleaning. In the stand-by position, eyewash heads are protected in a recessed area from airborne debris. A drain hose provided with unit. There are no loose parts to get lost or damaged. The highly visible yellow arm distinguishes itself from the Safety Green tank allowing it to be easily located and activated. It provides over 15 minutes of full flow pattern flushing at not less than 0.4 GPM (1.5 liters per minute). It can be wall mounted (bracket included) or shelf mounted. Hydrosep, bacteriostatic additive permits storage of water for several months. A thermal protection jacket, cart, and waste water container are available at an additional cost.



Part #	Description
7500	Eyewash, Gravity Operated, 16 Gallon, Portable

HYDROSEP

Model 9081 Hydrosep bacteriostatic additive for use in portable eyewashes is a solution preservative for use only with clean potable water. When used as directed, one 8 oz. bottle will preserve 5 to 20 gallons of potable water for up to six months. Follow the directions on the bottle. One carton contains four 8 oz. (236.8 ml.) plastic bottles.



Part #	Description
9081	Hydrosep, Bacteriostatic Additive, 4/bx

7100BT EYEWASH

This eyewash has a receptor made of Safety Green ABS plastic that is resistant to damage from alkalis, salt solutions, oils, most acids. The heads are Twin Soft-Flo* ABS plastic anti-surge eyewash heads in Safety Green. Dust covers protect heads and automatically release with water pressure. A stainless steel push flag operates the stay open chrome plated brass ball valve that is equipped with a stainless steel ball and stem. A universal language emergency sign is also included. The unit is Safety Green, per ANSI Z535.1-1991. Steady water flow under varying pressures is assured with automatic pressure compensation devices for 30-90 PSI. The single wide orifice flow control can be serviced if clogging occurs or exchanged if high or low water pressure is present. A fully serviceable in-line, 60x50 mesh strainer filters debris from reaching the eyewash. Removable cartridge on underside allows for easy cleaning. It mounts with an integral high strength ABS plastic wall bracket.



Part #	Description
7100BT	Eyewash, High Impact ABS Bowl, Wall Mounted

COMBINATION SHOWER EYEWASH OR EYE/FACE WASH

The 10" shower head is made from Safety Green ABS plastic. A rigid stainless steel pull rod operates a stay open chrome plated brass ball valve that is equipped with a stainless steel stem. Model 8226, has 30.0 GPM chrome plated brass assembly for flow control. It has a standard 9" diameter floor flange with 1 1/4" hot dip galvanized steel pipe. Stanchion incorporates an exclusive cast air gap/supply fitting that separates supply and waste. Two 21" long high visibility stripes in Safety Green and bright yellow improve visibility. The Eyewash and Eye/Face Wash have a Safety Green receptor made from ABS plastic that is resistant to damage from alkalis, salt solutions, oils, most acids. Model 8225 features Twin Soft-Flo* ABS plastic anti-surge eyewash heads in Safety Green. Dust covers protect heads and automatically release with water pressure. Model 8226 has Twin Feather-Flo* ABS plastic eye/face wash heads in Safety Green with integral flip top dust covers that protect heads and automatically release with water pressure. A stainless steel push flag operates a stay open chrome plated brass ball valve that is equipped with a stainless steel ball and stem. A universal language emergency sign is included. Made in Safety Green, per ANSI Z535.1-1991, designating safety and location of first aid and safety equipment. Steady water flow under varying pressures is assured with automatic pressure compensation devices for 30-90 PSI. The single wide orifice flow control can be serviced if clogging occurs or exchanged if high or low water pressure is present.

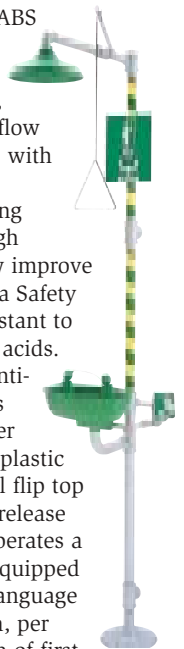

Part#	Description
8225	Floor Mounted Shower, Hand Operated with Eyewash
8226	Floor Mounted Shower, Hand Operated with Eye/Face Wash





MIRACOOOL

MiraCool cooling crystals, encased within 100% cotton fabric, absorb and hold up to 1,000 times their weight in cool refreshing water. MiraCool crystals work in combination with the evaporation process. When worn against the head, neck, or body, cooling sensations are passed to pulse points and carried throughout the body. MiraCool products are ideal for factory, construction and laundry room workers, welders, painters, chefs or anyone working or playing in a warm environment, indoors or out. Just soak them in cold water for 10-20 minutes. They stay hydrated for several days. Reuse them thousands of times. MiraCool increase alertness and productivity and works without freezing or ice.



#940 BANDANA



#954 HEADBAND

STAY COOL AND COMFORTABLE WHILE WORKING OR PLAYING IN HOT ENVIRONMENTS WITH A MIRACOOOL BANDANA OR HEADBAND.



#968-01 Hard Hat Pad

The head has many blood vessels close to the skin which influence body temperature. MiraCool Hard Hat Inserts use your head to stay cool.

Part #	Description
968-01	MiraCool, Hard Hat Pad, Navy

Part #	Description
940-01	Bandana, MiraCool, Navy Blue*
940-HVO	Bandana, MiraCool, High Viz Orange*
954-01	Headband, MiraCool, Navy*

*Other colors available

PHASE CHANGE COOLING SYSTEM

- Superb in searing heat
- No evaporation required
- Wear directly against body
- No frostbite or pain
- Energize in minutes
- Lasts for hours
- No pumps, mechanical devices or tethering
- Charge in ice water or freezer
- Perfect for Hazmat suits



PCP2 (pair)
Fits PC2A & PC2B Vests



PCP1 (pair)
Fits PC1 Vest

- Submerge Cool Packs in ice and water for 20-30 minutes or in refrigerator or freezer for 30-45 minutes. The clear liquid will phase change to a white semi-solid.
- Insert energized Cool Packs into fabric vest and affix them into position. Slip vest on and adjust shoulder and side straps.



PC1

PHASE 1 VEST

Shirt Style - 3.3 lbs.
More than 20" Reflexlite®
Comes w/PCP1 Cooling Packs



PC2A

PHASE 2A VEST

61% MoreCooling Coverage
Shirt Style - 3.3 lbs.
More than 30" Reflexlite®
Comes w/PCP2 Cooling Packs



PC2B

PHASE 2B VEST

Same as 2A
PLUS
More than 68" Reflexlite®
Comes w/PCP2 Cooling Packs

First Aid

GATORADE®

Gatorade is the optimal mix of carbohydrates to speed fluid absorption and prevent dehydration. It supplies rapid delivery of fluids and energy to help improve work performance. Gatorade contains the optimal amount of carbohydrates, providing energy to delay fatigue and allow workers to go longer, and stronger. It improves work performance more than that of drinking water alone. The scientific formulation of Gatorade helps your workers maintain peak job performance. The FDA classifies Gatorade as a "low sodium" beverage. Sodium plays a key factor in maintaining fluid balance and is essential for rapid fluid absorption. Gatorade is formulated with 110 mg of sodium per 8oz to help replace lost fluids and restore fluid balance. However, less sodium in a rehydration drink is less effective in replacing what you lose in sweat. It contains no caffeine or carbonation, which are the last things you want in a rehydration beverage. Carbonation inhibits drinking and can cause throat burn and stomach bloating. Caffeine and alcohol impair rehydration by promoting urine production and fluid loss.



Part #	Description	Size
03965	Gatorade, Instant Powder, Lemon-Lime, 8.5 OZ Pack makes 1 Gallon	80PK/CS
03966	Gatorade, Instant Powder, Orange, 8.5 OZ Pack makes 1 Gallon	80PK/CS
03807	Gatorade, Instant Powder, Fruit Punch, 8.5 OZ Pack makes 1 Gallon	80PK/CS
33878	Gatorade, Instant Powder, Glacier Freeze, 8.5 OZ Pack makes 1 Gallon	80PK/CS
33674	Gatorade, Instant Powder, Riptide Rush, 8.5 OZ Pack makes 1 Gallon	80PK/CS
03969	Gatorade, Instant Powder, Lemon-Lime, 21 OZ Pack makes 2 1/2 Gallon	32PK/CS
03970	Gatorade, Instant Powder, Orange, 21 OZ Pack makes 2 1/2 Gallon	32PK/CS
33691	Gatorade, Instant Powder, Fruit Punch, 21 OZ Pack makes 2 1/2 Gallon	32PK/CS
33677	Gatorade, Instant Powder, Glacier Freeze, 21 OZ Pack makes 2 1/2 Gallon	32PK/CS
33673	Gatorade, Instant Powder, Riptide Rush, 21 OZ Pack makes 2 1/2 Gallon	32PK/CS
03944	Gatorade, Instant Powder, Variety pack, 21 OZ Pack makes 2 1/2 Gallon	32PK/CS
03967	Gatorade, Instant Powder, Lemon-Lime, 51OZ. Pack makes 6 Gallons	14PK/CS
03968	Gatorade, Instant Powder, Orange, 51OZ. Pack makes 6 Gallons	14PK/CS
33690	Gatorade, Instant Powder, Fruit Punch, 51OZ. Pack makes 6 Gallons	14PK/CS
33676	Gatorade, Instant Powder, Glacier Freeze, 51OZ. Pack makes 6 Gallons	14PK/CS
33672	Gatorade, Instant Powder, Riptide Rush, 51OZ. Pack makes 6 Gallons	14PK/CS
00901	Gatorade, 11.6 oz. Cans, Lemon-Lime	24/CS
00902	Gatorade, 11.6 oz. Cans, Orange	24/CS
30903	Gatorade, 11.6 oz. Cans, Fruit Punch	24/CS
33840	Gatorade, 11.6 oz. Cans, Citrus Cooler	24/CS



*Lemon-Lime, Orange, Fruit Punch, Glacier Freeze, Riptide Rush



RUBBERMAID® WATER COOLERS

- Drip-resistant spigot; leak-resistant lids
- Insulated to keep water or beverage cold
- Rubbermaid® is the industry leader in water coolers

ASK ABOUT MOUNTING BRACKETS & CUP DISPENSERS

Part #	Description
1692	Rubbermaid water cooler, orange, 2 gallon
1683	Rubbermaid water cooler, orange, 3 gallon
1695	Rubbermaid water cooler, orange, 5 gallon
1610	Rubbermaid water cooler, orange, 10 gallon
1640	Rubbermaid water cooler mounting bracket
8250	Rubbermaid water cooler 4oz. cup dispenser

**SPECIALTY COOLER
COLORS AND IMPRINTS
QUOTED UPON REQUEST!**



SOLO® CONE WATER CUPS
Rolled rim paper cone cups.

Part#	Description
4H	Solo 4oz. cone water cups, 200 sleeve/25sleeves per case

IGLOO® 400 SERIES PLASTIC WATER COOLERS

Rugged, durable Igloo 400 Series Industrial Strength Water Coolers keep water cold, clean and available. The 400 Series takes the abuse of the roughest job site and the most punishing work crews.

- HDPE hide won't chip, peel, buckle or rust
- Reinforced handles and cup dispenser bracket

ALL PARTS ARE REPLACEABLE - FOR EXTENDED LIFE

Part #	Description
421	Igloo 400 series, 2 gallon
431	Igloo 400 series, 3 gallon
451	Igloo 400 series, 5 gallon
4101	Igloo 400 series, 10 gallon





ZV3C

ZV3C

JACKET STYLE VESTS

This vest has a zipper front and has no ties, velcro or elastic. 360° fluorescent orange for visibility. Made of a lightweight polyester knitted mesh and the striping is made of 3M™ Scotchlite™ reflective material.



MSUVY

MSUVY

MESH SURVEYORS VEST

This vest has 2 outside pockets for pens & markers along with 2 large inside pockets. The striping is made of 3M™ Scotchlite™ reflective material. For an additional set up charge and per vest charge, this vest can be customized with your company logo.



ESVR
3/4

ESVR

ECONOMY VEST

Lightweight polyester material, fluorescent orange with 3/4" lime striping and a velcro front closure.



ANSI-CLASS II LEVEL II - #2261

Class II is for use in traffic areas over 25 m.p.h. but under 50 m.p.h. Exceeds Class I specifications. Meets highest rating of class II highest vest rating. Covers Class I and II. 2 vertical stripes and 2 horizontal stripes of 1 3/8" reflective material either lime or silver. This vest has a zipper or velcro front closure.



ANSI-CLASS III LEVEL II - #3261

Class III is for use in traffic areas over 50 m.p.h. 2 vertical stripes and 2 horizontal stripes of 2" reflective material either lime or silver. This vest has a zipper or velcro front closure.



CSV

CSV-COTTON SURVEYORS VEST

100% cotton surveyors vest with lime stripe over shoulders and around the waist along with pockets on front inside and outside.

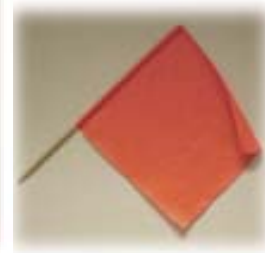

FLG24

24" Warning Flag with a 36" Staff.

If you don't see the Safety Vest you need to get the job done, ask our EXPERIENCED TEAM MEMBERS for more information.

Part #	Description	Size
ZV3C	Safety vest, jacket style stripes made of 3M™ Scotchlite™ reflective material	S - 4X
FLG24	Warning flag with 36" staff	N/A
MSUVY	Mesh surveyor vest, 13 pocket, stripes made of 3M™ Scotchlite™ reflective material	S - 4X
CSV*	Cotton surveyor vest, jacket style, stripes made of 3M™ Scotchlite™ reflective material	S - 4X
ESVR 3/4	Safety vest with elastic sides and Velcro front, stripes made of 3M™ Scotchlite™ reflective material	OS
2261	ANSI-CLASS II LEVEL II, 2 vertical stripes and 2 horizontal stripes of 1 3/8" 3M™ Scotchlite™ reflective material	S - 5XL
3261	CLASS III LEVEL II, 2 vertical stripes and 2 horizontal stripes of 2" 3M™ Scotchlite™ reflective material	S - 5XL

*All vests come in size large. For an additional charge they can be specially made in sizes small up to 6 X-large.

Traffic / Signs

DELINEATOR POSTS STRAIGHT OR T-Top



Features:

- Available heights: 18", 28", 36", 39" and 42"
- Base weights available 18, 12, 15, 18 & 12 lbs.
- Designed for maximum visibility, quick set-up and low maintenance.
- All posts feature a 'flare-bottom' designed with one-inch wide right angle flare. Insures positive locking of post and base.
- Some models come standard in length, or they can be custom cut to your specifications.
- Available in: Fluorescent orange, yellow, or white

ADDITIONAL FEATURES WITH THE T-TOP DELINEATOR POST:

- Standard with molded lower handhold grip.
- Convenient T-Carry Handle (a Bent Mfg. Co. exclusive) and molded in bolt hole for flashing light (new longer handgrip area)
- Improved recesses create a deeper area for reflective bands.
- 3/4" stronger ribs provide maximum band protection.
- Bent T-Top delineator post are manufactured using state-of-the-art technology. New precision molding machines produce consistent, high quality parts.

*Both style delineator Posts have been tested and certified to meet the crashworthy requirements of NCHRP-350.

TYPE III BARRICADE



Features:

- Durable, hot rolled high carbon steel construction with universal mounting holes
- Easy to assemble, bolt together, very portable
- Unique base design allows for short term or permanent securing.
- Engineered to accommodate two flashing lights
- Weather resistant baked enamel paint
- Accommodates reflective sheeting on both sides
- Design allows multiple barricades to be joined to extended length
- Type III Barricades to be joined in series to provide perimeter protection
- High wind stability
- Tested and certified to meet the cashworthy requirements of NCHRP-350.



MASTERFLEX SURFACE MOUNT CHANNELIZER POSTS



Features:

- Available heights: 18", 24", 28", 36", 39" 42" and 48"
- The new Masterflex post available in two models—a 180° two-way direction channelizer, or a 360° full-view direction channelizer. Both models incorporate the latest molding techniques and materials technology.
- High Impact Resistance—the Masterflex post is designed to with stand numerous high speed traffic impacts with minimal adverse effect.
- New Base Technology—a new concept in a one piece, hollow molded rubber base. Made from the highest elastic natural rubber available (Hy-Last®).
- The Masterflex Post is also effective in K-marker applications.
- Tested and certified to meet the crashworthy requirements of NCHRP-350.

UNIVERSAL PLASTIC BARRICADE



Features:

- Latest technology in stress and impact absorption.
- Bent Mfg. exclusive waffle-board design on back.
- Recessed areas for sheeting.
- Unique recessed molded light mount brackets sized for standard bolts.
- Protective anti-skid/wear tabs on bottom of legs.
- Non-shifting tacking lugs.
- Capable of internal sand ballasting.
- Custom name molding.
- Barricade lays flat upon impact.
- Holds many sizes of signs.
- Resistance to extreme temperatures.
- Convenient molded carry handle.
- Tested and certified to meet the cashworthy requirements of NCHRP-350.

**If there is a
Bent Manufacturing Co. item
you need to get the job done
safely, ask the
EXPERIENCED SALES STAFF AT PowerPlus
for more information.**

ALLMARK INTERNATIONAL

CAUTION SERIES

Caution signs should be used where there is a potential hazard or to warn against unsafe conditions. Caution signs are available in pressure sensitive vinyl, rigid plastic and aluminum. Sizes available are 3" x 5" (vinyl only), 7" x 10", 10" x 14", 14" x 20". Please see chart below for proper suffix to add to the part number for desired size and material.



C-308



C-310



C-311



C-312



C-322

NOTICE SERIES

Notice signs are used to convey information not necessarily of a safe nature, but tend to avoid confusion and misunderstandings. Please see chart below for available sizes and materials.



N-604



N-644



N-648

DANGER SERIES

Danger signs should be used where immediate hazards exist. The bright colors assure instant identification of dangerous situations that can cause injuries, loss or even death. All OSHA specifications to size, color designs and copy are met in these quality markers. Danger signs are available in pressure sensitive vinyl, rigid plastic and aluminum. Sizes available are 3" x 5" (vinyl only), 7" x 10", 10" x 14" and 14" x 20". Please see chart below for desired size and material and proper suffix to the catalog number when ordering.



D-210



D-219



D-220



D-240



D-241



D-246



D-250



D-253



D-257



D-272



D-285

Size and Material Chart

Size	3" x 5"	7" x 10"	10" x 14"	14" x 20"
Material				
Pressure-Sensitive Vinyl	VS	VM	V	VH
.030 Rigid Plastic		RM	R	RH
.032 Aluminum		Am	A	AH

ALLMARK INTERNATIONAL

STAND UP FLOOR SYMBOL SIGNS

These versatile signs are great for marking temporary hazards. The sturdy polyethylene construction folds for convenient storage. Floor Symbol signs are reversible – printed with 2 messages and can be used with either message facing out.



FS-101

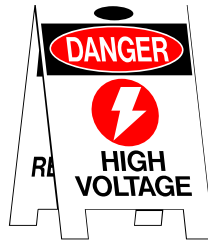

FS-103



FS-109

Part #	Description	Color
FS-101	Stand up floor symbol sign, "CAUTION - Wet Floor" & "CAUTION - Slippery When Wet"	Yellow
FS-103	Stand up floor symbol sign, "CAUTION - Men Working" & "CAUTION - Hazardous Area"	Yellow
FS-109	Stand up floor symbol sign, "Danger - High Voltage" & "Warning - Restricted Area"	White

FIRE SIGNS

Be sure your fire safety equipment can be quickly located in every emergency situation. Furnished in bright red ink on white pressure sensitive vinyl, rigid plastic and aluminum. Add suffix "V" for vinyl, "R" for rigid plastic and "A" for aluminum to part number.



FX-604
9" x 12"
R-V



FX-629
4" x 12"
R-V



FX-630
4" x 18"
A-R-V

INFORMATION

The information series signs clearly and effectively get the identification, safety or direction message across. Signs in this series are available in pressure sensitive vinyl, rigid plastic or aluminum. Add suffix "V" for vinyl, "R" for rigid plastic and "A" for aluminum to the sign item number. Special legends are available upon request.



I-102
10" x 14" A-R-V



I-108
8" x 10" A-R-V



I-120
10" x 14" A-R-V



I-138
9" x 12" A-R-V

Ask our

EXPERIENCED SALES STAFF AT PowerPlus

for information on customizing your company sign order today!

ALLMARK INTERNATIONAL

ACCIDENT PREVENTION TAGS

Plastic Tags with "Write On" Surface (Size 3" x 5 3/4")

- Conform to OSHA Specification 1910.145 for accident prevention tags.
- Durable, all plastic – withstands wear & tear, dirt, grease, moisture, stains, corrosion, acids, other harmful plant conditions.
- Standard 3" x 5 3/4" rigid plastic tag, with 2 rounded corners.
- Affix the suffix "w" to indicate without grommets.
- Other legends available.
- Packages of 25 identical tags and ties unless otherwise specified.
- No broken packages.

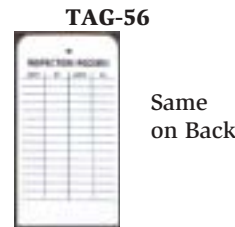
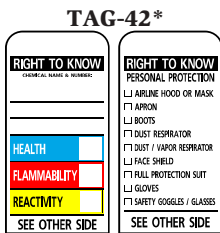
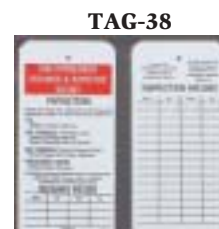
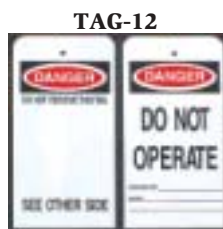

Same on Back

* Sold in packages of 10

NFPA SIGNS AND LABELS

Identify hazard chemical containers, storage tanks and other potential hazards with our NFPA code 704m compliant signs. Available in a variety of sizes and materials, please see the descriptions below for specifics.

Blank NFPA Panels

Fill in as you need them. Available in both rigid plastic "R" or self adhesive vinyl. Add an "R" to the end of the part number for the plastic signs.

Part #	Description
HWL-15	Blank NFPA panels, 15" x 15"
HWL-10	Blank NFPA panels, 10" x 10"
HWL-5	Blank NFPA panels, 5" x 5"
HWL-2	Blank NFPA panels, 2" x 2"

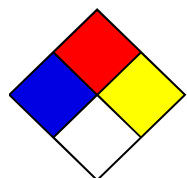

Blank NFPA Panel

NFPA/HMIS Wallet Guide

Small enough to be carried in a wallet or pocket, yet filled with reference material for NFPA and HMIS. These guides are great employee hand-outs.

Part #	Description	Quantity
HWG-2	NFPA/HMIS wallet guide, 3 3/8" x 2 1/8"	10/pk

Hazardous Material Sign

Pre-printed NFPA panel ideal for instructional use.

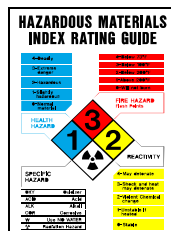

Hazardous Material Sign

Blank NFPA panel, add your own numbers.

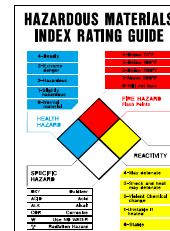

Part #	Description
HWL-20-R	Hazardous Material Sign, Pre-printed, rigid plastic, 14" x 10"
HWL-20-V	Hazardous Material Sign, Pre-printed, self adhesive vinyl, 14" x 10"
HWL-30-R	Hazardous Material Sign, Blank NFPA panel, rigid plastic, 14" x 10"
HWL-30-V	Hazardous Material Sign, Blank NFPA panel, self adhesive vinyl, 14" x 10"

ALLMARK INTERNATIONAL

NFPA SIGNS AND LABELS

Identify hazard chemical containers, storage tanks and other potential hazards with our NFPA code 704m compliant signs. Available in a variety of sizes and materials, please see the descriptions below for specifics.

Numbers & Symbols for NFPA Signs

Diecut numbers: 0, 1, 2, 3, 4.

Symbol panels: Acid, Alk, Cor, Oxy, Rad, W

Standard Pack, 10 of same item: add number or symbol desired to end of part number.

NEW Express Pack: 3 of ea. number, 1 of ea. symbol

Express Pack: add EK to end of part number.

ALL PACKAGES CONTAIN SAME SIZE NUMBERS OR SYMBOLS

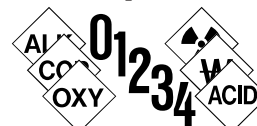

EXPRESS PACK

*Use suffix shown in description to the left

Part #	Description
HN-6-*	6" height, fits HWL-15
HN-4-*	4" height, fits HWL-10
HN-3-*	3" height, fits HWL-5
HN-1-*	1" height, fits HWL-2

Write-On NFPA Labels

Self adhesive paper labels are great for use on bottles.

Part #	Description	Quantity
HWL-34-2-250	Write-On NFPA labels, 2" x 2"	250/roll
HWL-34-2-500	Write-On NFPA labels, 2" x 2"	500/roll
HWL-34-4-250	Write-On NFPA labels, 4" x 4"	250/roll
HWL-34-4-500	Write-On NFPA labels, 4" x 4"	500/roll

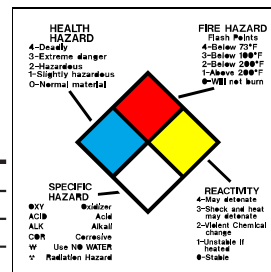

WRITE-ON HAZARDOUS COMMUNICATION LABELS



Write-On HMIS Labels

These self-adhesive paper labels are an inexpensive way to mark large quantities.

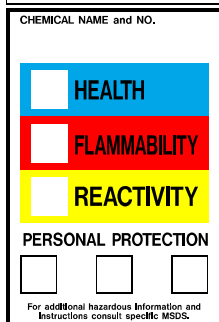

HMIS Labels

Write in your chemical name, add our easy to use number and symbols and you are ready to use these durable vinyl labels.

Part #	Description	Quantity
HWL-38-2-250	Write-On HMIS labels, 2" x 2"	250/roll
HWL-38-2-500	Write-On HMIS labels, 2" x 2"	500/roll
HWL-38-4-250	Write-On HMIS labels, 4" x 4"	250/roll
HWL-38-4-500	Write-On HMIS labels, 4" x 4"	500/roll
HWL-22	HMIS Labels, 3" x 5"	10/pk
HWL-23	HMIS labels, 4" x 6"	10/pk
HWL-24	HMIS labels, 7" x 10"	5/pk

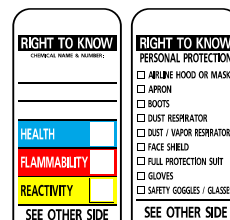

Tag-42

RIGHT TO KNOW TAGS

These 3" X 5" rigid tags are 10 per pack with nylon fasteners.

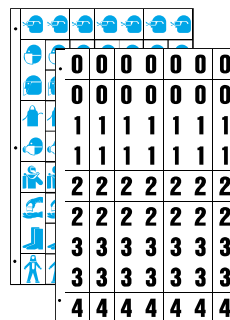

Numbers & Health Hazard Pictograms

Designed for use with HWL-22, HWL-23 and HWL-24. Numbers are 0-4 on 1 sheet. Pictograms are 7 ea. of 9 different pictures on 1 sheet. Just peel and stick.

Part #	Description	Quantity	Fits on Label #
HWN-35	Small Pictogram	5	HWL-22 & HWL-23
HWN-40	Large Pictogram	1	HWL-24
HWN-37	Small Numbers	5	HWL-22 & HWL-23
HWN-42	Large Numbers	1	HWL-24

ALLMARK INTERNATIONAL

SAFETY SCORE BOARDS

Our highly visible safety score boards are a great way to show employees their current and best safety record. Made of 20" x 28" .032 aluminum with an erasable scoring area to keep track of days safely completed.



SSB-52



SSB-54

HAZARDOUS / NON-HAZARDOUS WASTE MATERIAL WASTE LABELS

Off-site transportation of hazardous material requires use of labels by Federal Law. All current DOT and EPA regulations are met with these labels. Self-adhesive vinyl labels are available in packages of 25 or rolls of 500 (add the suffix "L" to catalog number). Size 6" x 6" unless otherwise specified.

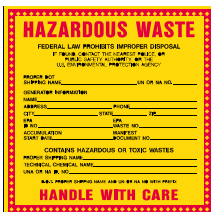

HW-255



HW-257

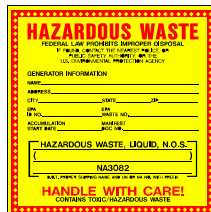

HW-258

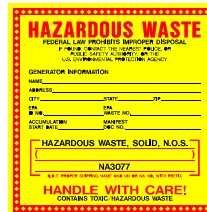

HW-259



HW-260



HW-262

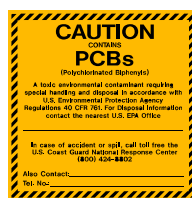

HW-266



HW-268

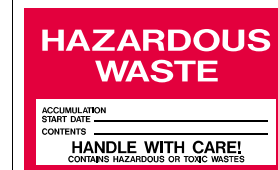

HW-270
4" x 6"



HW-272
(packs of 25 only)

ALLMARK INTERNATIONAL

THE RIGHT CENTER

RIGHT TO KNOW AND HAZARDOUS MATERIAL SUPPLIES TO HELP YOU COMPLY WITH THE LATEST OSHA REGULATIONS

RTKC-110 RIGHT TO KNOW CENTER



This 24" x 30" high impact plastic display features three 4" deep pockets. The complete center includes the 2 1/2" MSDS binder with a 36" chain and 10 booklets "Hazards in the Workplace: Your Right to Know". The pocket can be personalized with your company name or department.

RTKC-110-BL - BILINGUAL RIGHT TO KNOW CENTER



The RTKC-110 - RIGHT TO KNOW CENTER printed with the bilingual message contains all the same products as our original, booklets are split 5 English and 5 Spanish. MSDS Binder and booklets are available as separate items. Binders have a 2 1/2" spine.

RTKC-300 - EASY CLEAN RIGHT TO KNOW CENTER



Display your RIGHT TO KNOW data in this highly visible center. The PVC wire pocket is sturdy and can be sprayed off for easy cleaning. This display includes binder, chain and ten booklets.

HWLC-100 HAZARDOUS MATERIALS POSTER



OSHA Labeling Standards and NFPA Coding Systems are combined here in one easy to read colorful source. Printed on .010 unrippable vinyl 22" x 25 3/4"

MSB-300 ENGLISH MSB-350-SP SPANISH BINDER GUIDES

8 1/2" x 11" laminated guides are a handy way to meet training requirements. Designed to fit in your M.S.D.S. binder for quick look up. The front is identical to poster shown above-back has detailed written instruction.

MSB-300 ENGLISH - front/back

MSB-300-SP SPANISH - front/back



Part #	Description
RTKC-110	RIGHT TO KNOW CENTER, 24" x 30" high impact plastic
RTKC-110-BL	Bilingual RIGHT TO KNOW CENTER
MSB-116	MSDS Binder, 2 1/2" spine
MSB-114	Booklet (English)
MSB-114-SP	Booklet (Spanish)
RTKC-300	Easy Clean RIGHT TO KNOW CENTER
MSB-300	Binder Guides-English
MSB-300-SP	Binder Guides-Spanish
HWLC-100	HAZARDOUS MATERIALS poster

PELICAN PROTECTOR® EQUIPMENT CASES

Watertight and airtight to 30' for the ultimate in protection. Constructed of light-weight space age structural resin with a neoprene O-ring seal and exclusive purge valve. Supplied complete with pre-scored pick n' pluck foam or padded dividers (no cutting required). Also includes locking flanges, massive multiple latches for absolute security and a comfortable molded fold down handle. Integral personalized nameplate engraved at optional cost. Custom colors and foam inserts fabricated on special order. Private label logos available. #1700 and #1750 supplied with regular foam, pick & pluck is not available.

Part #	Outer Dimension	Inner Dimension
1120 Case, Guard Box	8 1/2" L X 6 1/2" W X 3 5/8" D	7 3/8" L X 4 7/8" W X 3 1/8" D
1150 Case	9 1/4" L X 7 3/4" W X 4 1/2" D	8 1/2" L X 6" W X 3 3/4" D
1200 Case	10 3/4" L X 9 3/4" W X 5" D	9 1/2" L X 7 1/2" W X 4 1/2" D
1300 Case	10 3/4" L X 9 3/4" W X 7" D	9 1/2" L X 7 1/2" W X 6 1/2" D
1400 Case	13" L X 12" W X 6" D	12 1/4" L X 9 1/4" W X 5 1/4" D
1450 Case	16" L X 13" W X 7" D	15" L X 10 1/2" W X 6" D
1500 Case	18 1/2" L X 15 1/4" W X 6 7/8" D	17" L X 11 3/4" W X 6" D
1520 Case	19 1/4" L X 15 1/2" W X 7 1/2" D	18" L X 12 7/8" W X 6 3/4" D
1550 Case	20 3/4" L X 16 3/4" W X 8 1/2" D	19" L X 14" W X 7 3/4" D
1600 Case	23 1/4" L X 20 3/4" W X 9" D	22" L X 17" W X 8" D
1650 Case	31 1/2" L X 20 3/4" W X 11 1/2" D	29" L X 18" W X 10 1/2" D
1700 Case, Travel Vault II	37" L X 17 1/2" W X 6" D	36" L X 13 1/2" W X 5" D
1750 Case, Travel Vault	52" L X 17 1/2" W X 6" D	50 3/4" L X 13 1/2" W X 5" D



PELICAN
PRODUCTS USA



VERSABRITE® (Six Lights in One)

Water resistant. Tested Lumen Value: 7, Watts 1.8 Peak Beam Candlepower: 6,000. VersaBright features Pelican's 6,000 candlepower Xenon high-performance LMX lamp module. Multiple position (o-ring sealed) swivel head. Made of Xenoy® unbreakable chemical resistant resin. Includes: large multiple use visor cap/clothing clip, Night Vision and BugsAway™ lens, Velcro® mounting system, adjustable headband, strong removable saddle magnet, and 2 AA-cell Energizer® alkaline batteries. FM, EX, CE CSA, MSHA approved non-incendive. Packaged on a color hang card. Non-Glare black only, 3" long, 1 3/4" wide, 1 7/8" high. Not for scuba applications. VersaBrite II covers four times the area of the VersaBrite collimated beam. Includes: Tested Lumen Value: 8.8, Peak Beam Candlepower: 8,000, Multiple user visor cap/clothing clip, two night vision disks (red & blue green), and 2 AA-cell alkaline batteries. Length: 4 1/8", Height: 2 3/8", Swivel Head: 1".



KING PELICAN LITE™ PRO 4000 Series

Water resistant. Tested Lumen Value 251.4, Watts 14.4 Peak Beam Candlepower 100,000. 12 volt, 14 watt, 100,000 candlepower, primary hand held light source. Made of an unbreakable ABS housing with a high impact polycarbonate lens and thermoplastic rubber shroud. Includes: dual filament Xenon safety lamp with 60 hours of lamp life (30 hours each), protective lens shroud, and a shock absorbing internal battery module that protects 8 D-cells from hard abuse. Combination pistol grip/lantern handle quickly converts to multiple positions. Choice of Laser Spot™ or Modified Spot™ quick change reflectors. Operates 10-12 hours on 8 D-cell alkaline batteries (not included). FM, EX, CE, CSA approved. Colors: Black, Yellow, Orange, Blue. 9" long, 4 1/2" diameter.



Part #	Description
2250BK	Flashlight, Versabrite, Deluxe, Black
2270	Flashlight, Versabrite II, Black
2270C	Flashlight, Versabrite II, Big Beam, Black

Part #	Description
4000BK	Flashlight, King Pelican Lite Pro 4000, Black
4000YL	Flashlight, King Pelican Lite Pro 4000, Yellow
4000OR	Flashlight, King Pelican Lite Pro 4000, Orange
4000BL	Flashlight, King Pelican Lite Pro 4000, Blue

STEALTHLITE®

Water resistant. Tested Lumen Value 31.5, Watts 3.8 Peak Beam Candlepower 10,000. Unbreakable ABS body with a high impact polycarbonate lens and thermoplastic rubber shroud. Features Pelican's state-of-the-art Laser Spot™ Xenon lamp module with an unsurpassed white collimated light beam. FM, UL, EX, CE, CSA, MSHA approved non-incendive. Includes: one-handed safety switch operation, double shock mounted battery compartment, and black lanyard. Operates 5-6 hours on 4 AA-cell alkaline batteries. Full color individual clampack hang card. Colors: Black, Yellow, Orange, Lime Green, Hot Pink. 6 1/2" long, 1 5/8" diameter.



Part #	Description
2400CBK	Flashlight, StealthLite, Black
2400CYL	Flashlight, StealthLite, Yellow
2400COR	Flashlight, StealthLite, Orange
2400CLG	Flashlight, StealthLite, Lime Green
2400CHP	Flashlight, StealthLite, Hot Pink

XENON LASER SPOT®

Modular Lamp Technology Dual Filament Back-Up Safety

State-Of-The-Art dual filament lamp and circuit technology matched to a computer tuned precisely focused reflector assembly. Pelican's exclusive lighting instruments are light years ahead of all imitators.



Part#	Description
2204	Lamp Module, for Versabrite
2206	Lamp Module, for Versabrite II
2404	Lamp Module, for StealthLite
4003	Lamp Module, for King Pelican Lite Pro 4000



PELICAN PRODUCTS USA



Plant Maintenance

STANDARD INDUSTRIAL

Bright Star® industrial flashlights set the standards—proven designs based on decades of experience as “America’s First Choice” in the workplace and proven toughness and reliability to match. All models are impervious to oil, grease, and most chemicals. Unbreakable Tuflexx® lenses, and self-cleaning slide switches. Model 2618 uses 2 D-cell batteries.



Part #	Description
2618	Flashlight, Standard, 2 D-Cell, Yellow & Black

HEAVY DUTY INDUSTRIAL

Bright Star® heavy duty industrial flashlights are the originals and still the strongest and most reliable you can buy. High-visibility yellow cases and black fittings. Unbreakable Tuflexx® lenses that resist even hammer blows. Self-cleaning slide switches tested to over 250,000 cycles. Model 1618 uses 2 D-cell batteries and has reinforced threads.



Part#	Description
1618	Flashlight, Heavy Duty, 2 D-Cell, Yellow & Black

SAFETY APPROVED FLASHLIGHTS AND LANTERNS

You can rely on Bright Star to meet all safety standards. No one has more experience in working with safety requirements and domestic and international certification. Bright Star carries the largest selection of safety flashlights and lanterns. CIRCUIT BREAKER PROTECTION. Cases in international orange for positive identification of our safety lighting tools.

SAFETY FLASHLIGHTS

These flashlights have a self-cleaning slide switch, switchguards, spare bulb holders, and ring hangers.



SAFETY LANTERNS

2206 6-Volt, waterproof, uses #466-M or #466-A battery and KPR-113 bulb, floats upright, spare bulb holder, UL listed Class I, Group D. MSHA approved. CSA approved Division 1, Class I, Group C, D and Class II, Group 6.

BRIGHT STAR®

Part#	Description
2117	Flashlight, Safety Approved, 2 D-Cell, Orange & Black
2124	Flashlight, Safety Approved, 3 D-Cell, Orange & Black
2217	Flashlight, Safety Approved, Waterproof, 2 D-Cell, Orange & Black
2224	Flashlight, Safety Approved, Waterproof, 3 D-Cell, Orange & Black
2206	Lantern, Safety Approved, Waterproof, 6-Volt, Orange & Black
466-M	Lantern Battery, 6-Volt

Safety Classifications

All Bright Star Safety Approved flashlights described carry the following classifications:

- Mine Safety And Health Administration Hazardous areas of methane and air mixture.
- Underwriters Laboratories Class I, Groups C & D hazardous vapors and gases. Class II, Group G hazardous areas of atmosphere containing flour, starch or grain dust.
- C.S.A. CERTIFIED - Canadian Standards Association
- American Society For Testing And Materials (ASTM) - US Maritime standard specification ASTM F1014-86 for flashlights on vessels: ASTM identification is molded into tube of 2117, 2217, 2220, & 2224.
- 2124 ASTM is hot stamped into tube. I order with suffix ASTM.

Type II - For hazardous locations (flammable gases and vapors) 2117, 2217, 2220, & 2124 ASTM.

Type III - For lifeboats/life rafts, and hazardous locations.

International Approvals - information available upon request, including information covering other models of specially constructed flashlights supplied to the international market according to local safety regulations.

DURACELL® PROCELL® ALKALINE BATTERIES

Duracell® Procell® Alkaline batteries provide long lasting dependable service even after 5 years of storage. They last up to five times longer than super heavy duty batteries and have a long service life at high drain discharges. They operate reliably in temperature extremes of -4°F to 130°F (-20°C to 54°C). Recommended storage conditions are 50° F (10°C) to 77° F (25° C) with no more than 65% relative humidity.

Part#	Description	QTY.
PC1300	DURACELL PROCELL, Alkaline Batteries, D	12/BX
PC1400	DURACELL PROCELL, Alkaline Batteries, C	12/BX
PC1500	DURACELL PROCELL, Alkaline Batteries, AA	24/BX
PC1604	DURACELL PROCELL, Alkaline Batteries, 9 Volt	12/BX
PC2400	DURACELL PROCELL, Alkaline Batteries, AAA	12/BX



DURACELL®

Plant Maintenance



#R3D



#W2D



#KLF



#IN-2



#301



#944

#918

#6V-HDM



#Alkaline batteries

Part #	Description	Pack
AL-D	Rayovac Alkaline Maximum™ Batteries D size	6 pack
AL-C	Rayovac Alkaline Maximum™ Batteries C size	6 pack
AL-AA	Rayovac Alkaline Maximum™ Batteries AA size	8 pack
AL-AAA	Rayovac Alkaline Maximum™ Batteries AAA size	8 pack
AL-9V	Rayovac Alkaline Maximum™ Batteries 9V size	6 pack
6V-GP	Rayovac 6-Volt Spring Terminals General Purpose	1 ea
6V-HD	Rayovac 6-Volt Spring Terminals Heavy Duty	1 ea
942	Rayovac 6-Volt Screw Terminals General Purpose	1 ea
944	Rayovac 6-Volt Spring Terminals Heavy Duty Maximum™	1 ea
945	Rayovac 6-Volt Screw Terminals Heavy Duty Maximum™	1 ea
918	Rayovac 6-Volt Screw Terminals General Purpose	1 ea
926	Rayovac 12-Volt Screw Terminals General Purpose	1 ea
W2D*	Workhorse flashlight, Sure grip design, Krypton bulb for 200% brighter and whiter beam	1 ea
L295-B*	Floating Lantern, Floats with beam shining upward, Long range beam, Weather resistant	1 ea
R3D*	Roughneck, rugged, dual function light, Adjustable spot flood, Tough polypropylene case	1 ea
KLF*	Krypton floating lantern, Long range beam, Rugged construction, Waterproof	1 ea
301	Sealed Beam Lantern with 918 Battery	1 ea
IN-2*	Industrial flashlight, Toolbox Tough, Contractor Grade, prismatic reflector gives a full, even spot pattern	1 ea
IHLT4D*	Headlight, Spare bulb included, Belt Clip on Battery Pack, light shines where you are looking	1 ea

*FLASHLIGHT BATTERIES SOLD SEPARATELY

Plant Maintenance

#345 RUBBER BRUSH™



ENTRANCE MATTING. Made with solid SBR rubber construction that allows the matting to remain flexible in extreme cold. With thousands of flexible “fingers” acting as scrappers as weight of traffic passes over. A bordered wall with beveled edging contains moisture and debris within mat reducing tripping hazard. With an overall thickness of 5/8” for use in exterior and interior heavy traffic areas. Suction cups on the underside help to reduce shifting and movement of mat. Available in black.

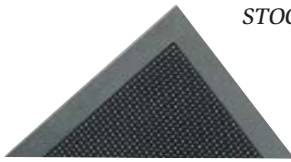

STOCK 16” x 24”
24” x 32”
28” x 46”
32” x 39”
36” x 60”
36” x 72”

#479** CUSHION TRAX™

ANTI-FATIGUE.DRY. Top surface consists of a non-directional, vinyl diamond that increases traction, and resists greases and oils. The backing is laminated to 3/8” resilient sponge back that provides superior fatigue relief. The beveled edges on all four sides help this mat to lay flat for trip-resistant access. For use in a dry, heavy use environment with an overall thickness of 9/16”.

Available in black with yellow, green, orange, or red. Also available in solid black or gray. Colored borders comply with O.S.H.A. #1910-144. Use in conjunction with #520/522.



STOCK	CUSTOM
2’ x 3’ 3’ x 5’	2’ wide 3’ wide
3’ x 12’ 4’ x 6’	4’ wide
	Maximum length: 60’

**Warranty is voided if usage includes spike heels or stools

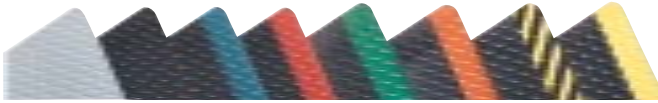

#410 AIRUG™



ANTI-FATIGUE.DRY. Made with a closed cell polyvinylchloride (PVC) sponge that helps to relieve leg and back discomfort. With a rib-top style surface, this mat should be used in dry work environments. All four edges are sealed and beveled to help reduce trip hazard & resist moisture. Available in 3 different thicknesses, 1/4”, 3/8” and 5/8” to help enhance comfort. Various stock sizes, full rolls, and colors. Black with yellow or orange along with plain gray, brown, or black. Black-orange & black-yellow available in 1/4” and 3/8” only

STOCK	FULL ROLLS
1/4”:	1/4” & 3/8”:
2’ x 3’ 3’ x 4’	2’ x 60’ 3’ x 60”
3/8”, 5/8”:	4’ x 60’
27” x 3’ 27” x 5’	6’ x 60’ (3/8” black only)
2’ x 3’ 3’ x 5’	5/8”:
3’ x 12’	2’ x 30’ 3’ x 30’
	4’ x 30’

CUT LENGTHS AVAILABLE



#830* SWITCHBOARD MATTING™

ANTI-STATIC. Made with a Non-Conductive corrugated PVC that insulates against “grounding,” to prevent electrical shock. Overall thickness is 1/4” and for use in high-voltage electrical areas. Additional Specifications: Type 2; Class 2 benefits dielectric strength: 30,000 volts - Design use: 17,000 volts. Conforms to ASTM D178- Meets O.S.H.A. requirements. * Must be replaced every 12 months for optimum safety

FULL ROLLS 2’ x 75’
3’ x 75’
4’ x 75’

CUT LENGTHS ALSO AVAILABLE



#520/#522*** CUSHION-LOK™

Anti-Fatigue.Wet. Made of a solid PVC construction, 7/8” overall thickness with a raised diamond port-hole system which improves traction, and facilitates drainage. Highly resistant to industrial chemicals. To be used in heavy duty, wet work areas. Bold O.S.H.A.-colored ramps on 3 sides for easy access and identification. Reinforced wall pattern bottom surface to help provide fatigue relief while withstanding abusive loads. Factory-bonded modular design that allows for custom-design to fit specific needs. Colored borders comply with O.S.H.A. #1910-144 with the benefit of being used in conjunction with #479. Available in black with yellow, green, orange, or red. #522 Only: Co-polymer abrasive coating sealed to top for improved traction in hazardous conditions.

STOCK

30” x 36”	30” x 48”	30” x 60”
30” x 72”	30” x 96”	42” x 72”
42” x 96”	42” x 120”	

All stock sizes come with ramps attached to three sides.

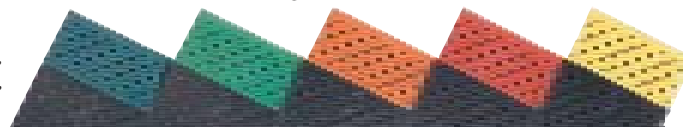

***Grip step™ not applied to color ramps

CUSTOM

Square Tiles: 12” x 12” increments
Ramp Edges: 6” x 12”
Corner Ramps: 6” x 6”

Plant Maintenance

TUFF MATE®

Extra strength shop rags. An ideal replacement for shop towels. Stands up to the toughest industrial cleaning tasks and out performs other heavy-duty disposable wipers. Can be rinsed and reused. Made from technologically-advanced strong Hydraspun® fabric which resists tears, absorbs quickly on contact, and holds its strength even when wet. 100 sheets per dispenser box; 8 boxes per case (800 sheets). **FTJ 250-80**



TWO-PLY SO-DRI®

Service Towels. Designed specifically for service station use. Ideal for cleaning windshields, headlights, mirrors and as dipstick wipers during oil checks. 10" X 10" blue sheets. 140 wipes per pack; 16 packs per case. **FTJ 293-90**



HIGHLY ABSORBENT

Multipurpose Wiping Cloths. Lint free washed white cotton knit cloths, made from unused pre-consumer waste cloth, not paper. Treated to increase absorbency. Excellent for dusting, polishing, painting and staining. 5 lb.s. of randomly sized cloths per dispenser box. **UNS-N205**



ULTRA WIPE SCRIM®

Reinforced Wiper. Reinforced toughness and durability. Surface picks up and holds dirt. For oil spills, auto repair and general maintenance. 13" X 13" blue sheets. 50 wipes per poly wrap; 16 packs per case (800 wipes). **FTJ 295-23**



TUFF-JOB® SCRIM

Reinforced Wipes. Four-ply wipes provide the advantages of rags and shop towels without the hassle of cleaning and storing. Reinforced to stop tearing.



Part #	Description
IFC 4058	Wipes, Quarterfold, 12" x 13", 50 per polywrap, 18 packs per case
IFC 420N	Wipes, Pop-Out Dispenser, 9 ³ / ₄ " x 16 ³ / ₄ ", 150 per dispenser, 6 dispensers per case

LIKE RAGS®

Cloth Rag Replacement Wipers. A cloth replacement towel. Crumpled packed, 250 per dispenser case.



Part #	Description
IFC 1100	Replacement Wipers, 14.4" x 14", 250 per dispenser case
IFC 1175	Replacement Wipers, 12" x 12", 250 per dispenser case

DUST'N CLEAN

Cleaning Cloths. Use in hand or attach them to a mop to clean floors, walls, ceilings and furniture. Disposable, 16" X 24" yellow cloths. 50 cloths per poly wrap; 4 packs per case (200 cloths). **FTJ 296-16**



SHUR-WIPE®

Wipers. Two ply construction provides strength and fast absorption. Ideal for cleaning glass, but tough enough for general maintenance work. White sheets. 125 wipes per box. **FTJ 298-11**



WIPE AWAY®

All purpose wiper. Absorbs quickly, holding twice its weight in liquid, grease or oil. Strong enough for industrial grime, yet soft enough for personal use. 13" X 13" white sheets. 50 wipes per poly wrap; 16 packs per case (800 wipes). **FTJ 292-15**



VALUE CHOICE®

All purpose wiper. Economical wiper offers superior absorbency with cloth-like softness. 12¹/₂" X 13" white sheets. 50 wipes per poly wrap; 16 packs per case (800 wipes). **FTJ 291-12**



WINDSOFT™

Nonperforated Roll Towels. Designed primarily for hand-drying in washrooms when combined with the appropriate dispenser. 7³/₄" in width, 350' per roll, 12 rolls per case. **WIN 780**



PREFERENCE®

Perforated Paper Towel Rolls

Two-ply, white ~ 11" x 8.8" sheets

FTJ 279-51 **FTJ 277**

JUMBO 250 sheets per roll, 12/cs >

< REGULAR 90 sheets per roll, 30/cs



BATHROOM TISSUE

- Soft, white, biodegradable, two-ply
- Individually wrapped rolls

FTJ 151 FTJ 158 FTJ 198 FTJ 180



Part #	Description
FTJ 151	Acclaim™ Bath Tissue, 3.9" x 4.5", 1000 sheets/roll, 48/case
FTJ 158	Acclaim™ Bath Tissue, 4.5" x 3.8", 500 sheets/roll, 96/case
FTJ 198	Acclaim™ Bath Tissue, 4.5" x 4.5", 500 sheets/roll, 96/case
FTJ 180	Preference® Bath Tissue, 4.5" x 4.5", 500 sheets/roll, 96/case

FALCON MIGHTY SONIC™

The Lightweight, Portable, Long-Lasting Safety Horn

Quality built for long-lasting use, totally independent of any other power source. Portable Mighty Sonic now features the 100% ozone safe, non-flammable formulation from America's #1 name in pressurized signaling products! It delivers a piercing 120dB blast at 10 feet. Convenient push-button operation. Provides hundreds of reliable 2 second blasts in each replaceable canister. Guaranteed durable high-impact trumpet.



Part #	Description
MSN4	Safety Horn, Mighty Sonic, Lightweight, Portable, Long Lasting
MSNR	Mighty Sonic Refill

FALCON SUPER SONIC™

Trigger-Activated All-Metal Safety Horn

Built for endurance, lasting power and portability, the ultra strong Super Sonic is now 100% ozone-safe and non-flammable! All-metal horns in bright red or deluxe chrome plating. Shrill, piercing blast can be heard over normal industrial noise. Quick trigger operation. Can be used by security guards, hazardous or remote-area workers, heavy duty machinery operators. Replaceable canister delivers hundreds of 2-second blasts.



Part #	Description
SSCN	Safety Horn, Super Sonic, Chrome, Trigger Activated, All Metal
SSN	Safety Horn, Super Sonic, Red, Trigger Activated, All Metal
SSNR	Super Sonic Refill

SOUND 911® HORN

A touch of the thumb, a little pressure, and the Sound 911® Horn will scream out with a blast of 112dB at 10'. Carried on its own clip for belt or bag, it can travel with you. Use against intruders/ prowlers/ muggers. No wires or batteries needed. If a worker is injured or otherwise needs to get attention, the Bound 911 will blast the signal instantly. Each replaceable canister will deliver over 100, 2-second piercing blasts. Recommended for emergency signaling in plants and offices, the Bound 911 Horn is also ideal for personal use in areas such as parking decks and on the street, to frighten muggers or unfriendly animals.

Part #	Description
911	Sound Horn, 911, Travel Size
911-2R	911 Refill, 2/PK



FALCON SAFETY SHOWER ALARM

Signaling Systems For Emergency Shower Configuration

Designed for instant signaling in any emergency drench shower -vertical, horizontal or floor-mounted. The Safety Shower Alarms are powered by Falcon's new Super Sonic Horn, with the 100% ozone-safe, non-flammable formulation! Chain connects to shower-pull so a loud blast is emitted the instant the shower is activated by a victim of chemical injury, burns, etc. No wires, batteries or auxiliary power required. A piercing blast (120dB at 10') can be heard over normal industrial noise. Falcon Super Sonic™ replacement canisters readily available. Please Note: The Falcon Safety Shower Alarm may be adversely affected by some chemical environments and weather conditions. Not recommended for use at temperatures below 32°F (-1°C).

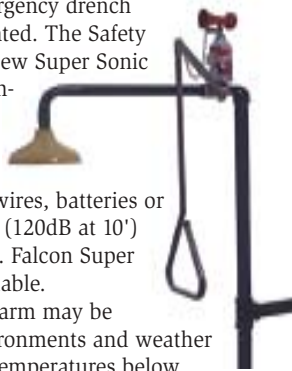

Part #	Description
SSA1N	Safety Shower Alarm, Super Sonic Horn, for Vertical Mount
SSA2N	Safety Shower Alarm, Super Sonic Horn, for Horizontal or Floor Mount Showers
SSNR	Super Sonic Refill

FALCON EMERGENCY ALARM STATION

Highly Visible Safety-Yellow Wall-Box System

The 100% ozone-safe, non-flammable Emergency Alarm Station is perfect for low-cost protection - independent of any additional power source! The 20 gauge safety-yellow steel wall box is easy to locate and relocate wherever you need it! Mounts with just two screws. Padlock and key system provides protection while permitting periodic testing. Emergency handle assures immediate access to horn... activated with the touch of a finger. The shrill, piercing blast can be heard over normal industrial noise. It can be used for fires, accidents, first aid calls, building evacuations. Falcon Super Sonic™ replacement canisters readily are available.



Part #	Description
TAD4N	Emergency Alarm Station, Super Sonic Horn
SSNR	Super Sonic Refill

FALCON®

KIDDE PRO LINE™ TRI-CLASS DRY CHEMICAL (ABC) FIRE EXTINGUISHERS



SPECIFICATIONS:

Part #	466227	466288	466112	466204	466206
Capacity (lbs.)	2.6	4	5	10	20
UL Rating	1-A: 10-B:C	2-A: 10-B:C	3-A: 40-B:C	4-A: 60-B:C	10-A: 80-B:C
Height (inches)	15	16	16	21.2	22
Width (inches)	5.3	7.8	7.8	7.4	8.8
Diameter (inches)	3.3	4.5	4.5	5.1	7
Shipping Weight (lbs.)	4.2	8.8	9.8	19.2	31.7
Cylinder Material	Alum	Alum	Alum	Steel	Steel
Bracket Type Furnished	wall hanger	wall hanger	wall hanger	wall hook	wall hook
Operating Pressure (PSI)	100	100	195	195	195
Discharge Time (Secs.)	8 -10	8 -10	13-15	19-21	19 -22
Range (Ft. Max)	6	12	18	20	20
Temp Range (°F)	-40 to +120	-40 to +120	-40 to +120	-40 to +120	-40 to +120

KIDDE

KIDDE PRO LINE™ REGULAR DRY CHEMICAL (BC) FIRE EXTINGUISHERS



SPECIFICATIONS:

Ordering Part #	466228	466086	466205	466207
Capacity (lbs.)	2.9	6	10	20
UL Rating	10-B:C	40-B:C	60-B:C	80-B:C
Height (inches)	14.4	18.9	19.3	21
Width (inches)	5.4	8	8.3	9.3
Diameter (inches)	3.25	4.5	5.2	7.2
Shipping Weight (lbs.)	4.7	10	16.6	31.3
Cylinder Material	Alum	Alum	Steel	Steel
Bracket Type Furnished	wall hanger	wall hook	wall hook	wall hook
Operating Pressure (PSI)	100	195	195	195
Discharge Time (Secs.)	8 - 12	13 - 15	17 - 25	20 - 25
Range (Ft. Max)	6	8	8	8
Temp Range (°F)	-40 to +120	-40 to +120	-40 to +120	-40 to +120

OPTIONAL VEHICLE BRACKET AVAILABLE WITH CERTAIN MODELS.

ASK AN EXPERIENCED PowerPlus TEAM MEMBER FOR MORE INFORMATION.



Spill Containment Pallets



Eagle makes forkliftable pallets for the containment of hazardous spills.



1645

1645 Four-Drum Low Profile Spill Pallet

- Polyethylene construction
- Meets EPA 40 CFR 264.175 requirements
- Holds four drums-62 gal. spill capacity
- Capacity: 8,000 lbs.
- Dimensions: 51" long x 51" wide x 10"
- Weight: 65 lbs.



1620

1620 Two-Drum Spill Pallet

- Polyethylene construction
- Meets EPA 40 CFR 264.175 requirements
- Holds two drums-68 gal. spill capacity
- Capacity: 2,000 lbs.
- Dimensions: 51" x 26" x 19"
- Weight: 54 lbs.



1647 shown w/optional ramp 1689

1647 Four-Drum In-Line Spill Platform

Low profile spill containment platform for keeping drums closer to the ground and closer to the wall and out of your limited work area. The low profile is very easy to load/unload drums with the optional ramp (Model 1689). Constructed of 100% high density polyethylene. Built-in internal and perimeter structural supports allows for 8,000 pound static load capacity. Raised walls prevent drums from accidentally slipping off of platform and meets EPA requirements 40 CFR 264.175.

- Polyethylene construction
- Meets EPA 40 CFR 264.175 requirements
- Holds four drums-63 gal. spill capacity
- Capacity: 8,000 lbs.
- Dimensions: 106" x 30.25" x 6.75"
- Weight: 74 lbs.

1660 Funnel and 1664 Funnel Cover

- High sidewalls contain spills and splashing when pouring
- Fits all 30- and 55-gallon closed head drums
- 18" diameter allows for use of drum fill gauge to measure contents
- Funnel spout fits into any 2" NPT bung
- Dimensions: 18" x 7" (funnel), 18.25" x 5" (funnel cover)
- Also available with brass screen to strain small parts
- Optional funnel cover (shown) keeps funnel clean and seals out contaminants



1660 with 1664

Part #	Description	Size
1620	Spill Containment Pallets, 2 drum - 68 gallon spill capacity	51 ¹ / ₂ " x 26" x 15"
1645	Spill Containment Pallets, 4 drum - 62 gallon spill capacity	51 ¹ / ₂ " x 51 ¹ / ₂ " x 10"
1647	Spill Containment Platform, 4 drum - 63 gallon spill capacity	106" x 30 ¹ / ₄ " x 6 ³ / ₄ "
1660	Accessory, Drum Funnel	18" x 7"
1664	Accessory, Drum Funnel Cover	18 ¹ / ₂ " x 5"



If you do not find your Eagle Product of choice ask an Experienced PowerPlus **Team Member** for more information!

1632 Two-Drum Modular Spill Platform

This platform comes with two 2' connection strips, allowing you to easily attach multiple units together to meet your unique containment needs. Flexible storage option for incidental spills and leaks. Constructed of 100% blow-molded high density polyethylene for superior strength and excellent chemical resistance. Low profile platforms provides for easier loading and unloading. Optional poly ramp (Model 1689) attaches securely to platforms. Optimize drum storage and use areas with customized layout. Can be shipped UPS Oversize.

- Polyethylene construction
- Holds two drums—30 gal. spill capacity
- Load Capacity: 5,000 lbs.
- Dimensions: 26.25" x 51.5" x 6.5"
- Weight: 32 lbs.



1649 Four-Drum Poly Outdoor Storage Building

Secure indoor or outdoor storage for up to 4 - 55 gallon drums. 62 gallon secondary spill capacity. Constructed of 100% molded polyethylene. 8,000 lb. UDL static load capacity. Lockable doors are vented to reduce fumes. 4-way fork lift pockets and top hooks for easy moving. Grating deck removes for easy cleaning. Compliance: EPA 40 CFR 264.175. Load with optional poly ramp (1689)

- Polyethylene construction
- Holds 4 drums—62 gal. spill capacity
- Dimensions: 57.25" x 57.25" x 72"
- Weight: 285 lbs.



1650 Lab Pack

- Constructed of High Density Polyethylene- incinerates completely
- Chemical resistant to most materials
- United Nations-certified to HM-181 (1H2/X75/S)
- Meets DOT 49 CFR 173.12(b) requirements
- Can be used with all packing groups - I, II, & III
- Handles suitable for forklift use
- Screw-on lid with gasket for positive seal
- Ideal as an easy access, weatherproof spill kit container
- Dimensions: 20.5" x 21.25"
- Capacity: 20 gal.
- Weight: 13 lbs.



Part #	Description	Size
1632	Modular Spill Platform System, 2 drum – 30 gallon spill capacity	51 ¹ / ₂ " x 51 ¹ / ₂ " x 18 ¹ / ₂ "
1649	Outdoor Drum Ploy Storage Building	57 ¹ / ₂ " x 57 ¹ / ₂ " x 72"
1650	20 gallon Lab Pack with screw top lid	20 ¹ / ₂ " x 21 ¹ / ₄ "
1689	Poly Ramp for 1645, 1686 and 1632	45 ¹ / ₂ " x 32" x 8"

TYPE I STEEL SAFETY CANS



TYPE II STEEL SAFETY CANS

Durable, coated steel cans have a power coat paint finish for maximum chemical resistance. This style is economically designed with a single spout from which you fill and pour. It's designed for carrying flammable liquids you'll be pouring into containers with wider openings. When you add a funnel/hose attachment you get accuracy when pouring into more restricted openings.

The one-pint to one-gallon models feature a fixed handle with trigger release cap for filling and pouring. The two- to five-gallon models feature a swinging handle designed for easy handling of 40-pound + loads.

All Justrite Type I cans have UL and/or FM-tested closures and pressure relief mechanisms, and free flow, double-mesh metal flame arresters which prevent ignition sources from entering without restricting liquid flow in or out.

10301, 10701 and 10801 approval listings are FM, UL, ULC.



Part #	Description	Size
10301	Type I can, 1 gal., steel	7 ¹ / ₄ "OD x 11 ¹ / ₂ "H
10501	Type I can, 2 gal., steel	9 ³ / ₈ "OD x 12 ⁵ / ₈ "H
10701	Type I can, 3 gal., steel	9 ³ / ₈ "OD x 16 ¹ / ₈ "H
10801	Type I can, 5 gal., steel	11 ¹ / ₂ "OD x 17"H

Rugged, coated steel Justrite Type II Cans have two openings. One for pouring. One for filling. They have all the features of a Type I can plus a built-in flexible metal hose for smooth, accurate, spill-free pouring into small openings like those you might find in bottles, plunge cans and small engines. A rear opening permits convenient filling.

10327, 10527 and 10821 approval listings are FM, UL, ULC



Part #	Description	Size
10301	Type II can, 1 gal., steel	9 ³ / ₈ "OD x 6 ¹ / ₂ "H hose 5/8" OD x 9"L
10501	Type II can, 2 gal., steel	9 ³ / ₈ "OD x 9 ³ / ₄ "H hose 5/8" OD x 9"L
10821	Type II can, 5 gal., steel	11 ¹ / ₂ "OD x 17"H hose 1" OD x 12"L

OILY WASTE CANS

Durable, galvanized steel cans are essential whenever solvent cloths and wiping rags are used. Can remains closed when not in use. When operated by hand or foot lever opening device, the cover opens up to a 60° angle and closes automatically when released.

Round construction and elevated bottom encourage circulation of air around can to disperse heat and prevent spontaneous combustion. One-piece cover facilitates use of collection bags.

Oily waste cans approval listings are FM, UL.



Part #	Description	Size
09100	Oily Waste cans, steel w/foot cover	11 ⁷ / ₈ " x 15 ⁷ / ₈ "
09300	Oily Waste cans, steel w/foot cover	13 ⁷ / ₈ " x 18 ⁷ / ₈ "
09500	Oily Waste cans, steel w/foot cover	16 ¹ / ₁₆ " x 20 ¹ / ₄ "

Ask our
Experienced
TEAM MEMBERS
about the **ACCESSORIES**
available for the
SAFETY CAN of your
Choice!



#25450

SAFETY STORAGE CABINETS provide central storage and organization for your flammable liquids. They save traveling time, minimize employee exposure and seal off your flammables when temperatures get too high. They're designed to meet safety requirements in a variety of applications: laboratories, production areas, automotive service/repair operations, schools, hospitals, printing and silk-screening plants, pharmacies and artists' studios- wherever space for flammable and hazardous liquids is needed and at a premium.

SAFETY CAN STORAGE for on-site storage for your flammable or combustibles. Provides hands-on access with minimal exposure. With either manual or self closing doors, along with 1 or 2 adjustable shelves these cabinets range from 30 to 60 gal. capacity.

25450 approval listings are FM, UL, N, O.

25452 approval listings are FM, N, O, U.



Approv./Listing-Regulations Key

FM - Factory Mutual tested and approved.

UL - Underwriters Laboratories listed.

N- Designed in accordance with specifications set forth in the National Fire Protection Association (NFPA) code 30.

O- Complies with OSHA regulations.

U - Complies with Uniform Fire Codes (self-closing door styles).



28234



SPILL CONTROL PALLET

Multifunctional units improve productivity, keep personnel safe from accidental slips, and limit exposure and clean-up costs from hazardous spills. 28234 and 28254 compliance listings are EPA, UFC.



28254

BENEFITS

- Seamless construction limits leaks
- Multiple structural supports handle heavy loads
- Fully compliant. Big sump captures and meets UFC and EPA spill containment regulations.
- Wide forklift pockets for easy relocation
- In-line pallets are ideal when space is a premium
- Low profile design is ideal for storing, collecting, dispensing, and more! Gray color hides dirt and keeps your workplace looking clean.
- Self-Locating, rugged polyethylene grates eliminate the chance of "ride-up" and remove easily for convenient cleaning
- Gator-Tuff 100% polyethylene is nearly impervious to chemicals including acids and corrosives

Part #	Description	Size
25450	Safety can storage cabinet, 2 dr., manual doors, 45 gal. capacity, 2 shelves	65" x 43" x 18"
25452	Safety can storage cabinet, 2 dr., self closing doors, 45 gal. capacity, 2 shelves	65" x 43" x 18"
28234	2-Drum In-Line Pallet, 66 gal. sump capacity, 2,500 lb. load bearing capacity, 45 lb. weight	49" x 25" x 15 1/2"
28254	4-Drum In-Line Pallet, 66 gal. sump capacity, 5,000 lb. load bearing capacity, 68 lb. weight	49" x 49" x 10 1/4"



Plant Maintenance

SPC™ OIL SORBENTS



When it's time to clean up or remove oil on land or water, SPC Oil Sorbents are convenient, lightweight and cost-effective. They absorb up to 25 times their own weight in petroleum products! They will not absorb water, will float indefinitely, are wringable, dustless, unaffected by temperature, flame resistant and impervious to both rot and mildew.



Part #	Description	Pack
ENV100	Pads, Oil Sorbent, Economy, Heavy Weight, 16"X20"	100/BALE
SPC810	Booms, Oil Sorbent, Strong, Lint-Free, No Gaps, 8"X10'	4/BALE

UXT™

Universal "Xtra Tough" Sorbent

UXT is a high-performance, virtually all-purpose sorbent. Outstanding in its ability to handle hazardous materials in maintenance, repair and operational environments, UXT is both oleophilic and hydrophilic, making it highly effective against oil, acids, solvents, bases, chemicals, coolants and antifreeze. UXT is 12 to 15 times more absorbent than clay, so you spend less on waste disposal. With UXT you avoid clay tracks and eliminates airborne clay particles. Perforation lets you use only the amount needed for a job, reducing waste removal expenses. Incineration residue is less than .02% ash. UXT's special gray core and black web coverstock masks unsightly stains and encourage longer use. UXT is available in two sizes of perforated pads, a perforated and unperforated roll, and as a folded roll.



MRO PLUS™ SORBENTS

SPC's MRO Plus™ sorbent is highly effective for cleanup and removal of oil and water-based liquids. A heavy-weight, gray dimpled material combining thickness, strength and high absorbency, the low-linting MRO Plus is suitable for virtually any industrial application. Like UXT, MRO Plus contributes to economy. Perforation permits the use of precisely the right amount of sorbent, and the product's dirt-masking grey color fosters longer use before disposal. Incineration residue of MRO Plus is less than .02% ash. Available in two sizes of pads, and in two sizes each of perforated and unperforated rolls.



Part #	Description	Pack
UXT500	Pads, Universal, Xtra Tough, Perforated, 16"X20"	100/CS
UXT514	Pads, Universal, Xtra Tough, Perforated, 14"X15"	50/CS
UXT519	Rolls, Universal, Xtra Tough, Perforated, 15"X125'	1/CS
UXT538	Rolls, Universal, Xtra Tough, Perforated, 30"X150'	1/CS
UXT505	Folded Roll, Universal, Xtra Tough, Perforated, 5"X100'	1/CS

Part #	Description	Pack
MRO100	Pads, MRO PLUS, Perforated, 16"X20"	100/BALE
MRO50	Pads, MRO PLUS, Perforated, 30"X30"	50/BALE
MRO15	Rolls, MRO PLUS, 15"X150'	1/BALE
MRO15-P	Rolls, MRO PLUS, Perforated, 15"X150"	1/BALE
MRO30	Rolls, MRO PLUS, 30"X150'	1/BALE
MRO30-P	Rolls, MRO PLUS, Perforated, 30"X150'	1/BALE

SPC™ SOCs™

SPC SOCs are dependable, flexible tubes that contain and absorb liquids. They mold around corners and conform to uneven surfaces to prevent and soak up spills and drips. These SOCs are wringable and incinerable.



OIL ONLY SOCs absorb oils and other non-water soluble chemicals without absorbing water or water-based solutions.



ALLWIK™ An all-purpose maintenance SOC with moderate chemical resistance that makes it suitable for most industrial applications.



HAZWIK® The choice when chemical resistance is critical. HAZWIK SOCs deliver excellent performance against aggressive fluids.

Part #	Description	Pack
OIL430	Socs, Oil Only, 3"X4'	30/CS
OIL412	Socs, Oil Only, 3"X4'	12/CS
OIL806	Socs, Oil Only, 3"X8'	6/CS
OIL124	Socs, Oil Only, 3"X12'	4/CS
AW430	Socs, ALLWIK, 3"X4'	30/CS
AW412	Socs, ALLWIK, 3"X4'	12/CS
AW806	Socs, ALLWIK, 3"X8'	6/CS
AW124	Socs, ALLWIK, 3"X12'	4/CS
HAZ412	Socs, HAZWIK, 3"X4'	12/CS
HAZ124	Socs, HAZWIK, 3"X12'	4/CS

ATTACK PAC™

Attack Pac™ is an efficient, space saving, single use kit packed in puncture and UV resistant foil bag. Hang anywhere from grommet or Attack Pac rack. Attack Pacs absorb up to 7 gallons per kit. Each kit contents: 15 Pads (16"x 20"), 3 SOCs - 3"x4', Goggles, Nitrile Gloves and 1 Disposal bag. Use an Attack Pac Rack for a convenient and highly visible display of spill kits. Holds a single Attack Pac.



Part #	Description	Pack
SKO-ATK	Attack Pack, Oil Only,	4/CS
SKA-ATK	Attack Pack, ALLWIK	4/CS
SKH-ATK	Attack Pack, HAZWIK	4/CS



ENVIROTEX™ UNIVERSAL ABSORBENTS

PADS

When it comes to cleaning work place spills or absorbing machinery mess, nothing works like Envirotex pads. Made from the same material as Envirotex rolls, but cut into convenient 18"x18" pads. The convenient size makes Envirotex pads an excellent tool for controlling oil spills, dripping machinery, and leaking equipment. They absorb up to 10 times their weight in fluid quickly. They have lower disposal costs than clay and require 25% less storage. These tough, durable pads are dustless and fire retardant. Packaged in convenient light weight cases, they are environmentally sound, made from 100% post consumer recycled textiles. Can be incinerated for disposal.



DRUM TOP PAD

Eliminate messy barrel tops. Envirotex Drum Top Pads absorb leaks and drips. The pads are pre-cut to fit a 5.5-gallon drum. Each pad covers the drum surface while allowing access to both bungs. Convenient size allows quick, easy protection against costly problems. Made from 100% post consumer recycled textiles. Universally absorbent (non-selective). They absorb up to 10 times their weight in fluid.



ROLLS

When you want a sorbent aisle mat to protect your flooring, reduce slipping, sop up leaks and spills, stop messy tracking of oil and other fluids, nothing works like Envirotex rolls. This new cleanup tool is made from 100% post consumer textile fibres that are reconstituted into a material that is tough, absorbent, fire resistant and dustless. Envirotex rolls are perfect to cover, protect and make safe your high risk, high traffic work places. They absorb leaks and oversprays and clean up spills. High absorbency so it lasts longer and you replace it less often. They quickly contains and controls oil and water based fluid. Roll out and cut to size. Requires minimal storage and handling.



Part #	Description	Size	Quantity
157738	Pads, Heavy Duty	18"X18"	50/CS
152225	Drum Top Pads	22" dia.	25/CS
127728	Roll, All Purpose	36"X150'	
127738	Roll, Heavy Duty	36"X60'	

SAW DUST

Used for many different absorbent needs.

ULTRASORB® PREMIUM

(Diatomaceous earth) This absorbent works well for oil & liquids and for fast economical removal of oil, grease, hydraulic fluid, coolant and water.

Part #	Description	Size
8833	Ultrasorb	33 1/3 lb. Bag
SD	Saw Dust	2.5 Cubic Ft. Bag

Plant Maintenance

CHEMICAL AND WASTEWATER CLASSIFIERS

Identify unknown elements of unknown liquids and wastewater discharge. Use either the SPILFYTER® Chemical or the Wastewater Classifier Strips to distinguish chemical risks in unknown liquid in seconds through color change. Chemical Classifier Strips indicate the possible presence of the following chemical risks: acid or base, oxidizers, fluoride, petroleum product, organic solvent, or iodine/ chlorine/ bromine. Wastewater Classifier Strips indicate the possible presence of the following chemical risks: acid or base, lead (Pb + +), petroleum products, organic solvents, hydrogen sulfide, or nitrite. In the event of a positive reading or you are not comfortable with the test results, have liquid tested by an analytical laboratory.

Chemical and Wastewater Classifier Kits

Kits Contain: Either 6 Chemical or Wastewater Classifier Strips, 1 bobbin of polypropylene thread, and a reusable Classifier Color Chart.



Part #	Description
570001	Chemical Classifier Kit
580001	Wastewater Classifier Kit

Chemical and Wastewater Classifier Stations

Contains: Either 20 Chemical or Wastewater Classifier Strips, 2 bobbins of polypropylene thread, and a reusable Classifier Chart. Kit components are stored in a weather-resistant ABS Plastic Cabinet: 13.5" x 9.5" x 2.25".



Part #	Description
571020	Chemical Classifier Station
581020	Wastewater Classifier Station

FORMALDEHYDE SPILL KIT

Designed to provide a safe way of cleaning up and reducing the vapors from small formaldehyde and glutaraldehyde leaks and spills.



Each kit contains:

- 1-Formaldehyde Vapor Suppressor Shaker Bottle
 - 4 - 3" x 4' KOLLECT-A-KEM Socks
 - 10 - 12" x 12" KOLLECT-A-KEM Pads
 - 1 - Scoop with Detachable Scraper
 - 1 - 18" x 30" Disposal Bag and Twist-tie
 - 1 - Disposal Label
- TO BE USED BY TRAINED PERSONNEL ONLY.

Part #	Description
480010	Formaldehyde Spill Kit

MERCURY SPILL KIT

This kit is designed to handle all stages of cleaning up a mercury spill. Mercury spills should be responded to by trained personnel. This kit does not contain any chemicals designed to make the mercury any less toxic or dangerous. Exercise extreme caution when handling, storing, or disposing of the used kit components. This kit is designed for a one-time use only. Instructions included. Sorbency Capacity: 25ml(0.75 lbs). Kit contains: 270 grams MERCSORB™ Powder, 250 grams Mercury Indicator Powder, 1- MERCSORB™ Vapor Suppressor, Shaker Bottle, 1- Mercury Aspirator Bottle, 1- Waste Mercury Collection Bottle, 1- Mixing Tub with Wooden Spatula, 1- Chemical Sponge, 1 pair Nitrile Gloves, 1- 15" x 15" Disposal Bag and Twist-tie, and 1- Whisk On Pan.



Part #	Description
520250	Mercury Spill Kit

HOW® OIL-SELECTIVE SORBENTS GRAB&GO®

PORTABLE SPILL KITS

Specifically designed for portability and quick action in containing all types of hydrocarbon liquids, such as oils, coolants, solvents, etc. before they migrate under valuable machinery or run down drains. Each GRAB&GO Bucket is packed with HOW® Oil-Selective Sorbents. Kit #305304 Contains: 4 - 3" x 4' Oil Selective Socks, 5 - 9" x 18" Oil Selective Pads, and 1 - 5 Gallon Plastic Bucket (Not UN-Certified).

Part #	Description
305304	Portable Spill Kit, Grab&Go, Oil Selective Sorbents



Plant Maintenance

#37-LINE FLOOR BRUSHES



SILVER FLAGGED-TIP PLASTIC. Staple set in clear lacquered half-round hardwood block. M60 Handle included.

Recommended use: For sweeping smooth, highly polished floor, varnished wood or smooth concrete. Will sweep finest dust or grit. DO NOT USE WITH OIL BASE SWEEPING COMPOUND. Length of trim: 3"

Part #	Description
3714	#37-Line Floor Brush, 14"
3716	#37-Line Floor Brush, 16"
3718	#37-Line Floor Brush, 18"
3724	#37-Line Floor Brush, 24"
3730	#37-Line Floor Brush, includes #99 brace, 30"
3736	#37-Line Floor Brush, includes #99 brace, 36"

#26 LINE FLOOR BRUSHES



BEST QUALITY BLACK HORSEHAIR AND PLASTIC BLEND BORDER, INSIDE BLACK SR GRADE PLASTIC. Staple set in clear lacquered half-round hardwood block. M60 Handle included.

Recommended use: For wet or dry sweeping. The brush will sweep fine or coarse debris on all types of surfaces. Length of trim: 3"

Part #	Description
2618	#26-Line Floor Brush, 18"
2624	#26-Line Floor Brush, 24"
2630	#26-Line Floor Brush, includes #99 brace, 30"
2636	#26-Line Floor Brush, includes #99 brace, 36"

#14 LINE GARAGE BRUSHES



PRIME STIFF PALMYRA FIBER. Staple set in clear lacquered streamlined hardwood block. B60 Handle included.

Recommended use: For wet or dry sweeping under rough conditions such as wet and greasy concrete floors in service stations, packinghouses, creameries, etc. Length of trim: 4"

Part #	Description
1416	#14-Line Garage Brush, 16"
1418	#14-Line Garage Brush, 18"
1424	#14-Line Garage Brush, 24"
1430	#14-Line Garage Brush, includes #99 brace, 30"
1436	#14-Line Garage Brush, includes #99 brace, 36"

#22A LINE GARAGE BRUSHES



COARSE BROWN PLASTIC. Staple set in clear lacquered flat-top hardwood block.

Recommended use: For wet or dry sweeping rough concrete and asphalt driveways. Also wet floors such as in breweries, bottling plants and creameries. Requires D-60 Handle/99 Brace optional. Length of trim 3"

Part #	Description
2218-A	#22-A Line Garage Brush, 18"
2224-A	#22-A Line Garage Brush, 24"
2230-A	#22-A Line Garage Brush, 30"
2236-A	#22-A Line Garage Brush, 36"

#300 AND 300Y DECK LINE BRUSHES



ACID-PROOF POLYPROPYLENE. The following deck brushes are filled with high quality Polypropylene. Staple set in a smooth sanded hardwood block with one threaded and one tapered handle hole. Length of trim: 2" Handles NOT included. Requires C-Series tapered or M series threaded handles.

Part #	Description
310	#300 Deck Brush, Brown, 10"
312	#300 Deck Brush, Brown, 12"
314	#300 Deck Brush, Brown, 14"
310Y	#300 Deck Brush, Yellow, 10"
312Y	#300 Deck Brush, Yellow, 12"
314Y	#300 Deck Brush, Yellow, 14"

BROWN PLASTIC



BROWN POLYPROPYLENE PLASTIC. Staple set in smooth sanded hardwood block. Wide flare on ends allows close sweeping to curbs.

Recommended use: For wet or dry sweeping in dairy barns, street sweeping, highway work, etc.

Length of trim: 5" Handles NOT included. Requires C54 or C60 handles.

Part #	Description
1616	Brown Plastic Brush, 16"
1618	Brown Plastic Brush, 18"
1624	Brown Plastic Brush, 24"

WHISK BROOM

Made from fine selected broom corn (no coarse corn). Sewed two times, cad. plated ring cap. This is best quality whisk broom for home, automobile and office.

Part #	Description
228	Whisk Broom, 11"
229	Whisk Broom, 15"



OSTRICH FEATHER DUSTER

Genuine Ostrich Feathers are the only feathers that collect and hold dust until shaken or washed. Extra-Soft, will not crack or break. Used by professional cleaners for a thorough and efficient dusting job.



Part #	Description
3550	Ostrich Feather duster, 12" overall
3551	Ostrich Feather duster, 19" overall
3552	Ostrich Feather duster, 13" overall
3553	Ostrich Feather duster, 24" overall

BEAVER-TAIL COUNTER DUSTERS

Filling material is staple set in clear lacquered hardwood block. Hang-up hole in handle. Brush face length: 9". Overall length: 13 1/2", Length of trim: 2 1/2"



Part #	Description
53	Horsehair & Blk. Tamp. Mix

BEAVER-TAIL COUNTER DUSTERS FOAM-PLASTIC BLOCK

Fiber staple set in tan foam block with hang-up hole in handle. Brush face length: 9". Overall length: 13 1/2". MEETS SANITARY CODE REQUIREMENTS.

Part #	Description
57	Duster, Green flagged nylon
61	Duster, White polypropylene



LARGE ANGLE BROOM

Flagged Cream Colored Plastic is secured in an angled plastic cap. 12" Angled sweeping surface enables you to sweep hard to reach corners and crevices.

- 55" long metal handle included
- 6 3/4" trim at peak
- Head Size 9" (head packed separate in poly bag)



Part #	Description
463	Large Plastic Angle Broom



HEAVY DUTY CONTRACTORS BROOM

Made of the best quality selected broom corn with palmyra stalk center. Sewed 4 times and reinforced with a wire band. Made on a 1 1/8" diameter clear-lacquered handle. This broom is ideal for use in the construction trade for sweeping moderate to heavy debris.

Part #	Description
5038	Contractors Broom

WAREHOUSE BROOM

Made of best quality broom corn and fiber. Sewed 4 times and reinforced with a wire band. Made on a heavy-duty handle. This broom was designed for sweeping smooth and rough surfaces having moderate to heavy dirt accumulations.

Part #	Description
5032	Warehouse Broom, 100% corn
5036	Warehouse Broom, corn & fiber



Plant Maintenance

***LID SOLD SEPARATELY**



TILT TRUCKS*

Made to handle bulky, medium to heavyweight materials. Sturdy, plastic construction. Easy to maneuver and dump contents. Wheels and axle are inset to prevent damage to interior surfaces and equipment. Gray color. (*Optional lid sold separately.) With capacity sizes up to 2300 lbs.

Available in: 1/2 Cubic Yard
1 Cubic Yard
1 1/2 Cubic Yard
2 Cubic Yard
2 1/2 Cubic Yard

TILT TRUCKS LIDS*

Domed, hinged lids conceal loads without reducing capacity. Gray color.

COMMERCIAL CAN LINERS

Linear Low-Density, Bulk Pack, Sable Brown

- Star seal bottom helps prevent leakage.
- Made from high quality blended resins for superior strength and puncture resistance.

GRADE	GAL. CAP.	SIZE	GAUGE/MIL.	BAGS/CASE
Light	10	24 x 23	.35	500
Light	15	24 x 32	.35	500
Heavy	20-30	30 x 36	.65	200
Heavy	33	33 x 39	.62	200
Heavy	40-45	40 x 46	.68	100
Heavy	60	38 x 58	.70	100



GOJO™

Original formula hand cleaner (cream)

Cleans the heaviest duty soils with or without water. Fortified with lanolin.

- 18 - oz. (12cs) – GOJ-1109
- 4.5 - lbs. (6cs) – GOJ-1111

SIMPLE GREEN®

All-Purpose Industrial Strength Degreaser \ Cleaner

Removes oil and grease from washable surfaces. Can be diluted for light to heavy cleaning needs. Use for pressure washing and steam cleaning, maintenance food processing and preparation, and parts washing. Exempt from O.S.H.A. and EPA requirements for special handling or personal protection for hazardous materials. Biodegradable, non-toxic, nonabrasive, nonionic, and nonflammable. USDA Classifications A4, A8, B2.



- 24 oz. Foaming Spray Trigger Spray (12/cs) – SMP-13012
- 1 Gal. (6/cs), 5 Gal. Pail OR 55 Gal. Drum – SMP-13005

WINDEX®

Powerized Formula™ Glass Cleaner

Institutional strength formula with Ammonia-D® has 45% more grease cutting action. Loosens soil upon contact. Won't streak or leave a film. Also cleans chrome, stainless steel, Plexiglas®, and other hard surfaces.

- 32 oz. Trigger Spray (12/cs) – DRK-90135
- 1 Gal. Refill (4/cs) – DRK-90940



CLOROX FORMULA 409®

Cleaner Degreaser/Disinfectant cleans and degreases virtually any hard, nonporous surface; no rinsing required. EPA-registered disinfectant formula: bactericidal and virucidal efficacy.

- 1 Gal. Jug – CLO-35300
- 32 oz. Trigger Spray – CLO-35306



CLOROX® CLEAN-UP®

Disinfectant Cleaner with Bleach

Cleans, disinfects and deodorizes hard nonporous surfaces in hospitals, commercial and institutional settings. Removes tough stains and greasy dirt.

- 32 oz. (9/cs) – CLO-35417
- 136 oz. (4/cs) – CLO-35416



Plant Maintenance



COTTON AND RAYON MOP HEADS

Made of 4 ply highly absorbent, long wearing yarns. Mops are sewed 2 times. Band is 1" wide.

Part #	Description
4716	16oz. Cotton
4724	24oz. Cotton
4732	32oz. Cotton
4816	16oz. Rayon
4824	24oz. Rayon
4832	32oz. Rayon



MOP HANDLES

Quick-change type. Heavily zinc plated steel construction securely fastened to a NO.1 grade 1¹/₈" diameter handle. Standard wing nut construction with channel-type cross bar that detaches from one side to allow quick change of mop head.

Part #	Description
91	Janitor Mop Handle



TAPERED HANDLES FOR DECK, WINDOW, & ROOF BRUSHES, SQUEEGEES, STREET BROOMS ETC.



SELECTED STRAIGHT-GRAINED HARDWOOD smoothly sanded with one rounded and other end tapered.* HANDLES ARE NOT LACQUERED

Part #	Description
C24	2 ft. Tapered handle
C48	4 ft. Tapered handle
C60	5 ft. Tapered handle
C120	10 ft. Tapered handle

METAL THREADED GARAGE BRUSH HANDLES



SELECTED HARDWOOD with clear lacquered finish. One end rounded and other end is equipped with crimped-on metal thread. Diameter: ¹⁵/₁₆"

Part #	Description
B60	Metal Threaded Handle, 5'
B72	Metal Threaded Handle, 6'
BW60	Wood Threaded Handle, 5'

HEAVY DUTY HANDLE BRACE D60 IRON CONNECTOR HANDLE

Part #	Description
D60	Malleable metal connector installed on best grade clear lacquered hardwood handle. Red tipped.
D60-C	Red Malleable metal connector.
99	Heavy-Duty handle brace made of aluminum bar stock. Complete with all screws and wing nuts.

#D60 Handle



#99 Brace



PLASTIC MOP BUCKET COMBO W/WRINGER

Yellow mop bucket with wringer designed for durability. Bucket accommodates 26 to 35 qts. and is corrosion resistant. No cracks or crevices to collect dirt. Wringer is resistant to cleaning chemicals. Comes with standard 3" ball bearing casters. Dimensions w/casters: 11⁷/₈" D x 18³/₈" L x 15¹⁵/₁₆" W

Part #	Description
6035-3	Plastic mop bucket



GALVANIZED PAILS

Hot-Dipped galvanized pail. Superior quality to pre-galvanized. Durable and long lasting containers for liquids. Will not crack or leak.

Part #	Description
4	2 Qt. Mini Pail
8	8 Qt. Pail
10	10 Qt. Pail
12	12 Qt. Pail
14	14 Qt. Pail
20	24 Qt. Pail





CURVED SQUEEGEE W/STEEL BRACKET HANDLE HEAVY DUTY



Part #	Description
4618	18" Curved Squeegee, Black Rubber
4624	24" Curved Squeegee, Black Rubber
4630	30" Curved Squeegee, Black Rubber
4636	36" Curved Squeegee, Black Rubber
4618N	18" Curved Squeegee, Neoprene
4624N	24" Curved Squeegee, Neoprene
4630N	30" Curved Squeegee, Neoprene
4636N	36" Curved Squeegee, Neoprene

To purchase with all steel handle, ADD an (S) to end of the part #.

#3 PLASTIC DUST PAN

Grey plastic janitor dust pan is durable, lightweight, non-marking and will not rust or dent. hang up hole in handle for storage.



METAL DUST PAN

Black metal janitor dust pan is 20 gauge steel. Baked enamel finish is durable with beveled edge. Corrugated ribs add to strength.



Part #	Description
6	Metal Dust pan, 12" edge
7	Metal Dust pan, 16" edge

WATER PAINT BRUSH

Best Grade White Tampico fiber staple set in clear lacquered hardwood block with 6³/₄" red handle attached. This is a heavily filled brush recommended for the professional contractor. Block size 6³/₄"L x 2"W, 4" trim.

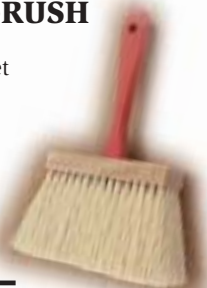

Part #	Description
561	Water paint brush/Five rows wide

ALL STEEL SQUEEGEE HAN

Can be used with the 46 & 46N line of squeegees. For use in the food processing industry, or wherever wood products are not permissible. ¹⁵/₁₆" diameter x 60" long. Overall length is 63".

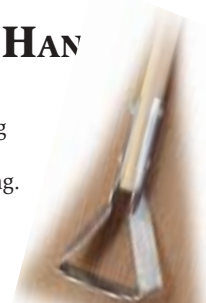

Part #	Description
4100-S	Steel squeegee handle

VEHICLE SQUEEGEE



Part #	Description
59053	8" Deluxe steel head with 20" wood handle, EPDM rubber blade, Heavy Duty sponge and nylon net, 24" overall length
59230	8" plastic head with 16" plastic handle, rust and scratch proof, 16" overall length
59263	8" Deluxe Plastic head with 20" handle, EPDM rubber blade, Heavy Duty sponge with plastic insert, Heavy Duty nylon net, 21" overall length

#5-SC-7 - PAINTERS SCRATCH BRUSH W/SCRAPER

Round Cardon Steel Wire. Staple set in wax tumbled hardwood block with scraper and handle bracket attached. For scaling and scraping old paint.



Part #	Description
5-SC-7	Scratch Brush w/scraper

PRE-GALVANIZED TRASH CAN W/LID

Durable/long lasting containers for refuse.



Part #	Description
Trash Can	20 gallon w/lid
Trash Can	30 gallon w/lid



NORTH
Safety Products

V-SAFE™ Wheel Valve Lockouts

- VS02 - 1" to 2-1/2"
- VS04 - 2-1/2" to 5"
- VS06 - 5" to 6-1/2"
- VS09 - 6-1/2" to 10"
- VS13 - 10" to 14"



Made of strong polypropylene plastic and fully dielectric. Highly resistant to cracking and abrasion. Available in red, yellow, blue or green.

M-SAFE™ Safety Lockout Hasps

MS01

Heavy duty nylon safety lockout hasp, heat and cold resistant, dielectric, highly flexible, holds up to 6 padlocks.



B-SAFE™

Ball Valve Lockout

- BS01 - Valves from 3/8" to 1-1/4"
- BS02 - Valves from 1-1/2" to 2-1/2"
- BS03 - Valves from 2" to 8"

B-SAFE ball valve lockouts are made of polypropylene plastic and are fully dielectric. Highly resistant to solvents and other chemical products. Available in red, yellow, blue and green.



B-SAFE™

Butterfly Valve Lockout

BS04

Universal lockout for butterfly valves is made of strong polypropylene plastic and is fully dielectric. Highly resistant to solvents and other chemical products. Available in red, yellow blue or green.



C-SAFE™

Circuit Breaker Lockout

CB01

A single pole lockout, CB01 requires a switch breaker with a recessed hole.



C-SAFE™

Circuit Breaker Lockout

CB02

This double pole lockout requires the breakers to be connected with a cross bar for lockout application.



C-SAFE™

Circuit Breaker Lockout

CB03

A single pole lockout, CB03 does not require a switch breaker with a recessed hole.



C-SAFE™

Circuit Breaker Lockout

CB04

This double pole circuit breaker lockout will fit most major brands of electrical circuit breakers.



E-SAFE™ Electrical

Switch Lockout

ES01

This easy to install device can be used in either the "on" or "off" position with most mounted switches.



ELA290/1

DO NOT OPERATE

tags are made of stain resistant and mildew resistant 20 Mil styrene, 3" x 5-3/4". Also available with metal grommet.



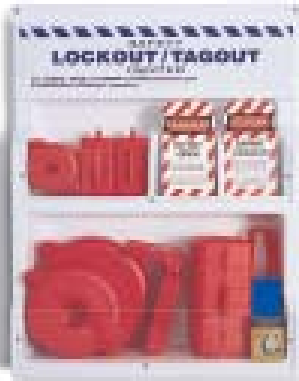

Lockout Center, 18" x 24" LSE101F

Highly visible Lockout/Tagout centers make your locks, tags, hasps and lockout devices easy to find.

Includes:

- | | |
|------------|---------------------|
| (1) LSE101 | (2) VS02 |
| (1) VS04 | (1) VS06 |
| (1) BS01 | (2) LP110 |
| (1) LP550 | (2) MS86 |
| (4) MS01 | (1) ELA290 (25 pk.) |
| (1) 3D | (1) ELA255 (25 pk.) |



Circuit Breaker Lockout Kit LK112F

Circuit breaker lockout kit in a convenient pouch that can be attached to a belt for easy use.

Includes:

- | | |
|-------------------------------------|-----------|
| (1) Double belt loop zippered pouch | |
| (3) ES01 | (1) LP110 |
| (4) CB04 | (4) CB03 |
| (1) CB02 | (2) CB01 |

Lockout Center, 24" x 35" LSE102F

Highly visible Lockout/Tagout centers make your locks, tags, hasps and lockout devices easy to find.

Includes:

- | | |
|------------|---------------------|
| (1) LSE102 | (2) VS02 |
| (1) VS04 | (1) VS06 |
| (1) VS09 | (1) BS01 |
| (1) BS02 | (2) LP110 |
| (1) LP550 | (2) MS86 |
| (6) MS01 | (1) ELA290 (25 pk.) |
| (2) 3DLF | (1) ELA255 (25 pk.) |
| (2) 3D | (1) ELA250 (25 pk.) |



E-SAFE™ Electrical Lockout LP110

Electrical plug lockout, completely encloses the plug from any accidental reconnection. Accepts 110V, up to 1-3/4" x 1-3/4" x 3-3/4". Maximum cable diameter of 1/2".



Lockout/Tagout Kit LK107FE

Lockout/Tagout kit provides all the necessary items to make lockout/tagout as convenient and easy as possible.

Includes:

- | | |
|-------------------------|----------|
| (1) Tool box w/tray 16" | (1) VS02 |
| (1) BS01 | (1) 3D |
| (1) 1DLJ | (1) MS01 |
| (5) ELA290/1 | (1) CB04 |
| (1) CB03 | (1) ES01 |
| (1) LP110 | |



E-SAFE™ Electrical Lockout LP550

Electrical plug lockout, completely encloses the plug from any accidental reconnection. Accepts 220V and 550V, up to 3" x 3" x 6-3/4". Maximum cable diameter of 1".

Plant Maintenance

MASTER-KEYED SYSTEMS



Individually Keyed

Individually Keyed

Individually Keyed

Individually Keyed

Submaster Key "A"
Opens only locks in group "A"

Submaster Key "B"
Opens only locks in group "B"

Submaster Key "C"
Opens only locks in group "C"

KEYED-ALIKE SYSTEMS

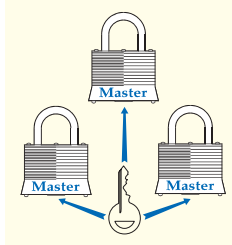

Master Key "ABC"
Opens only locks in group "ABC"

Master Key "D"
Opens only locks in group "D"

Grand-Master Key

OPENS ONLY LOCKS THROUGHOUT SYSTEM

PART #	DESCRIPTION
PADLOCK	1-1/2" (38 mm.) wide laminated steel body with hardened steel shackle
3D	Individually keyed, regular shackle
3DLF	Individually keyed, 1-1/2" shackle
3DLH	Individually keyed, 2" shackle
3KA	Keyed alike, regular shackle
3KALA	Keyed alike, 1-1/2" long shackle
3KALH	Keyed alike, 2" long shackle
3MK	Master keyed, regular shackle
3MKLA	Master keyed, 1-1/2" shackle
3MKLH	Master keyed, 2" shackle
2K	Master Key
PADLOCK	2" (50 mm.) wide laminated steel body with hardened steel shackle
5D	Individually keyed, regular shackle
5DLA	Individually keyed, 1-1/2" shackle
5DLH	Individually keyed, 2" shackle
5KA	Keyed alike, regular shackle
5KALA	Keyed alike, 1-1/2" long shackle
5KALH	Keyed alike, 2" long shackle
5MK	Master keyed, regular shackle
5MKLA	Master keyed, 1-1/2" shackle
5MKLH	Master keyed, 2" shackle
2K	Master Key

- MASTER-KEYED SYSTEMS-Supervisory master-key opens all locks in system yet each padlock also opens with a separate individual key. Permits organizing submaster, master and grandmaster systems along departmental or other functional lines, as illustrated (Padlocks are specially configured, regular lock will not accommodate Master-keying)
- KEYED-ALIKE SYSTEMS-Locks in KA sets employ identical keys. One key opens all in set.

NEW SAFETY LOCKOUT PADLOCKS

COMPLETE AND EASY OSHA DEVICE COMPLIANCE

Dedicated safety lockout padlock with 1.5" shackle. Available in 8 colors.



It's a safe bet you won't confuse our new safety lockout padlocks with any other locks. Seven vibrant colors, two sizes, and permanent write-on labeling allow for versatile, readily distinguishable coding. The Xenoy® body is lightweight and nonconductive, yet strong, durable and unaffected by the elements and harsh working environments. Even the keyway is unique, ensuring the integrity of your key system. A single, dedicated safety key is provided per lock and it's retained until the lock is closed, to aid in OSHA compliance. If you're looking to enhance safety, this is the lock you've been waiting for.

- Solid Body Bright Colors / 2 Body Sizes
 - Red-Orange-Green-Teal-Purple-Black-Blue
 - Easy identification by department or trade from distance
- Personal Integrated identification
 - Quick on-site employee ID capability with permanent write-on labels (2 labels supplied for each lock).
- Xenoy Body Construction
 - Tamper resistant, lightweight, non conductive body that is ultrasonically welded for strength and durability
 - Better chemical / harsh environment resistance over steel and aluminum products
 - Surpasses environmental industrial test criteria

Part #	Description	Qty.
410	1-1/2", 1-3/4" high, 1-1/2" shackle	1
410KA	Keyed Alike	1
410MK	Master Keyed	1
410KAMK	Keyed Alike, Master Keyed	1
410-5701	Label sheet for Padlock- "Property of" + "DANGER"	49
411	1-1/2" wide, 3" high, 1-1/2" shackle	1
411KA	Keyed Alike	1
411MK	Master Keyed	1
411AMK	Keyed Alike, Mastered Keyed	1
411-5701	Label sheet for Padlock - "Property of" + "DANGER"	28
400K	Master Key	1

Construction Products

CUT-OFF MACHINES BY **STIHL** POWERFUL AND TOUGH



When you think of concrete, metal, asphalt, masonry, stone and ductile iron, you think tough. And when these are the kinds of materials you're dealing with, you'd better think about a STIHL Cutquik®. Construction sites, demolition work or rescue operations – whenever the going gets rough – STIHL Cutquik® cut-off machines provide all the power and portability needed for fast, easy cutting.



TS 760AVE

The TS 760AVE STIHL Cutquik® is identical to the TS 510 but with a much larger engine. Designed for cart use and heavy-duty applications which require greater engine power. STIHL EASYSTART® system with decompression valve and 3-stage air filter are standard. New 16" version available for deeper cuts. TS 510 features include anti-vibration and STIHL'S exclusive EASYSTART® System with decompression valve. Dual air filter system is top mounted. It uses a 12" or 14" cutting wheel.

STIHL products may not be available at all PowerPlus locations.



TS 400

The TS 400 STIHL Cutquik® is a revolutionary concept from the world's number one name in cut-off machines. The differences in the TS 400 are easy to see: extremely long running times, a radical reduction in service intervals plus an outstanding cutting performance. Available with either a 12" or 14" cutting wheel, the TS 400 offers many features that are exclusive to STIHL including a semi-automatic belt tensioner, ELASTOSTART™ handle and EASYSTART® system.

STIHL CUTQUIK® CUT-OFF MACHINE ACCESSORIES

Part #	Description
4223-670-6000	Pressurized Water Tank, provides water for wet cutting attachments when pressurized water hose is not available
0463-901-0671	Carrying Case, heavy duty metal, has special compartments to hold all STIHL Cutquik® machines except TS 760, cutting wheels and various accessories
4201-710-1403	Cart, attaches to any STIHL Cutquik®. Particularly useful where long, straight cuts have to be made, such as cutting expansion joints in road surfaces or squaring off edges in asphalt.

VICTOR® EQUIPMENT COMPANY CONTRACTORS PLUS™

Customers who require maximum performance with a minimum of accessories will find the Contractors Plus™ an ideal package.

- Welds up to 1/8"/4mm and to 3"/76mm with larger nozzles.
- Cuts up to 3/4"/19mm and to 8"/202mm with larger tips.

"VAN GUARD™" models have 315FC torch handle with built-in check valves and flash back arrestors.

U.S. Patent #5407348



Part #	Description
0384-1311	STD CONTRACTORS PLUS™ with 315FC "VAN GUARD™" Handle



SAIT



#20161



#26003



#23068

Part #	Description
26003	Metal Grinding Cup Wheel, Type 11, Metal backing
23068	Thin High Speed Cut-Off Wheel, Type 1, Metal cutting
20161	Depressed Center Grinding Wheel, Type 27, Concrete Cutting

DESCO



**#34201- BLACK
29 PIECE SET**

- STRAIGHT SHANK**
1/16 - 1/2 by 64ths
- Jobbers Length
 - In Metal Box



Construction Products

Campbell® Chain

SYSTEM 7 BINDER CHAIN

w/CLEVIS GRAB HOOKS

- A complete line of tie down chains
- All chains listed may be used in accordance with the latest D.O.T regulations
- Yellow chromated System 7 chain with higher load-to-weight ratios
- System 7 use carbon hooks
- Do NOT USE FOR OVERHEAD LIFTING



Part #	Description	Size
0513574	System 7 Binder chain, with Clevis grab hooks	5/16" x 20'
0513575	System 7 Binder chain, with Clevis grab hooks	5/16" x 25'
0513665	System 7 Binder chain, with Clevis grab hooks	3/8" x 20'
0513667	System 7 Binder chain, with Clevis grab hooks	3/8" x 25'

SYSTEM 3, PROOF COIL CHAIN

BLU-KROME

- Uses: Excellent general-purpose chain of standard commercial quality
- Frequently used for fabricating tow chain, bining or tie down chain and logging chains
- Standard Material: Low carbon steel
- Available in Blu-Krome (B.K.) 3/16" through 1/2"
- Hallmarking: "C3" or "M3" and date code. 1/4 in. and smaller may alternatively have a "P" on every link
- Proof Tested
- Packaging: Drums (order unit is "Feet")
- Do NOT USE FOR OVERHEAD LIFTING



Part #	Description	Size
0120322	System 3, Proof CoilChain, Blu-Krome	3/16"
0120422	System 3, Proof CoilChain, Blu-Krome	1/4"
0120522	System 3, Proof CoilChain, Blu-Krome	5/16"
0120622	System 3, Proof CoilChain, Blu-Krome	3/8"

GILMOUR

FLEXOGEN, THE LAST HOSE YOU'LL EVER BUY.

- Patented 6-ply construction
- Flow guard Plus protective collar on 5/8" hoses resists kinks at faucet
- Over 500 PSI burst strength



Part#	Description	I.D.	Length
10-58050	Flexgen garden hose	5/8 in.	50 ft.
10-58075	Flexgen garden hose	5/8 in.	75 ft.
10-58100	Flexgen garden hose	5/8 in.	100 ft.
10-34050	Flexgen garden hose	3/4 in.	50 ft.
10-34075	Flexgen garden hose	3/4 in.	75 ft.
10-34100	Flexgen garden hose	3/4 in.	100 ft.

WHITE LIGHTNING®



IDEAL FOR DOORS, WINDOWS, WALLS, PIPES, HVAC, ROOFS AND MACHINERY

RTV SILICONE SEALANT is a 100% silicone rubber that forms a durable, flexible seal for long-lasting bonding, sealing and weatherproofing. This sealant features a removable, cleanable, reusable nozzle for a tighter seal. It is easily gunned in any type of weather and will not crack, crumble, shrink or discolor. This sealant resists moisture and provides excellent adhesion to non-porous materials.

Part #	Description	Color
WL09010	RTV Silicone Sealant	Clear
WL09210	RTV Silicone Sealant	White
WL09310	RTV Silicone Sealant	Aluminum



Construction Products



When a tough all-purpose measuring wheel is needed, nothing fills the order like the Rolatape 400 Series. Its 4-foot circumference handles the toughest measuring needs for heavy construction, large commercial operations, utility companies, land surveying and other critical measuring applications. When measuring demands are tough, the 400 Series gets the job done.

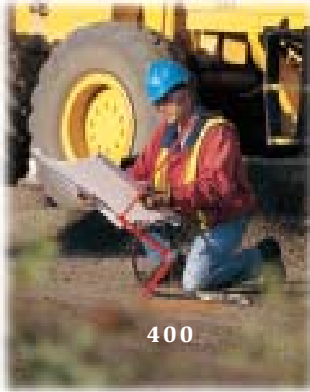

400

FEATURES:

- All steel construction - Heavy-duty strength and durability
- Dual counters available-Records more than one measurement at a time
- 4-foot circumference wheel - Easier to measure accurately on rough terrain
- Wheel stand - Keeps wheel upright when not in use
- Wheel brake - Transport to second site without losing measurement
- Professional series has a 5 year warranty



A money-saving workhorse is the best way to describe the MM-30. For longer indoor measuring needs and mid-range outdoor applications, the MM-30 shines. Real estate, road finishing, law enforcement, light construction and fencing needs are easily handled by this wheel. The standards of flexibility, durability and economy are set by the MM-30 Series.



MM 30

FEATURES:

- Silver power coat steel wheel - Lasting durability and good looks
- Brass axle bushings - Free-spinning wheel for easy rolling
- Safety-Green color - High visibility means a safer work environment
- 3-foot/1-meter circumference - Best all around versatility
- Lift-and-Lock handle - Easy storage and transport
- Measure Master series has a 3 year warranty

POWERLOCK®

TAPE RULE, 1" WIDE BLADE

- 3 rivet Tru-Zero hook
- Belt clip fastened on back of case
- Remains rigid up to 7' for hard-to-reach places
- LIFE GUARD® yellow blade for easy-to-read numerals.



Part #	Description	Length
33-425	Powerlock® Tape Rule, 1" Wide Blade	25 ft.
33-430	Powerlock® Tape Rule, 1" Wide Blade	30 ft.



#580-24
UNITEK ALUMINUM LEVELS



#991-9
TORPEDO LEVELS

- Solid I-beam frame; matched edges assure accuracy
- Replaceable acrylic vials
- Top reading window
- High visibility orange
- Beveled end plates protect from shock

- Heavy Duty-Magnetic Aluminum frame, 9" in overall length
- Top read window
- V-grooved working edge for pipe work
- Strong holding magnetic edge frees hands
- Vials read plumb, level and 45°

Part #	Description	Length
580-24	Unitek Aluminum Level	24"
580-48	Unitek Aluminum Level	48"
580-72	Unitek Aluminum Level	72"
991-9	Torpedo level, w/magnetic edge	9"
99-9	Torpedo level, w/no magnetic edge	9"



Construction Products



44-106
DURA-TORQUE® COLLAR
SQUARE POINT STEEL SHOVEL

45-106
DURA-TORQUE® COLLAR
ROUND POINT STEEL SHOVEL

- Better for transferring rocky & drier soils
- Steel collar for extra strength
- 48" White Ash handle for strength



Part #	Description
44-106	Union, square point shovel
45-106	Union, round point shovel

HOLLOW BACK SHOVELS BY PowerPlus



Hollow back blades are stamped from a single piece of steel which creates the hollow socket and adds strength to the blade. A nylon socket support also fortifies the neck. Forward turned steps provide for secure and comfortable foot placement. Handles are attached with a nylon collar and single rivet.

Part #	Description
HISS16D	16" Sharp shooter D handle
HISS16L	16" Sharp Shooter Long handle

PROFESSIONAL QUALITY



CrowBar

Intended for pinching and prying of large objects, such as heavy machinery parts. Sometimes referred to as "lining" bars, because of a millwright's use aligning equipment and machinery. Available with a pinch or a wedge point opposite a tapered round handle. Painted black.

Part #	Description
180PP	Crowbar, 1 1/4" x 60" Pinch Point
180WP	Crowbar, 1 1/4" x 60" Wedge Point



Post Hole

Designed to work ahead of post hole diggers in tightly packed or rocky soils. Manufactured with a digging blade on one end opposite a tamping head. Painted black.

Part #	Description
TB6	Post hole, 1" x 72" length



Digging Bar

Assists in the digging of holes in difficult soils. San Angelo and Telegraph styles have a round pencil point end. The constructor features a diamond point end. All digging bars are forged from hexagon shaped stock with a straight chisel-end blade. Finished with black enamel paint.

Part #	Description
170SA	Digging bar, San Angelo 1" x 60"



#245

#244

CONSTRUCTION AND SURVEY MARKING PAINT

Superior upside down marking paints that are designed to clearly and effectively mark the location of underground utilities. These solvent-based paints will mark almost any surface, including wood, concrete, asphalt, brick, and gravel. The patented spray-through cap is designed to be used in the #245 Aervoe Marking Stick, or #244 Spot Marker, or applied by hand.

Part #	Description
244	Spot Marker for single use hand delivery and precision
245	Marking Stick for upright operator line marking
200	Construction and Survey Marking Paint, Clear
206	Construction and Survey Marking Paint, Black
207	Construction and Survey Marking Paint, White
212	Construction and Survey Marking Paint, Purple
222	Fluorescent, Construction and Survey Marking Paint, Orange
224	Fluorescent, Construction and Survey Marking Paint, Green
226	Fluorescent, Construction and Survey Marking Paint, Yellow
227	Fluorescent, Construction and Survey Marking Paint, Blue
229	Fluorescent, Construction and Survey Marking Paint, Pink

Construction Products



Part #	Description
701-S	Dual Purpose Hack Saw, 16" overall length, 12" Blade
D213-9ST	High-Leverage Side Cutters for Rebar Work
D248-8	High-Leverage Diagonal Cutters with Angled Head
3239	Adjustable-Head Construction Wrench, Bolts up to 1 1/2"
D203-8	Heavy-Duty Long-Nose Pliers with Side Cutters



#248-8 #D203-8 #D-213-9st



#3239

ESTWING CLAW & RIP HAMMERS



Part #	Description	Approx. Head Weight
E3-12C	Claw Hammer, Nylon-VinylGrip	12oz.
E3-16C	Claw Hammer, Nylon-VinylGrip	16oz.
E3-20C	Claw Hammer, Nylon-VinylGrip	20oz.
E3-12S	Rip Hammer, Nylon-VinylGrip	12oz.
E3-16S	Rip Hammer, Nylon-VinylGrip	16oz.
E3-20S	Rip Hammer, Nylon-VinylGrip	20oz.

RIDGID



Part #	Description
31000	Straight Pipe Wrench, Cast Iron, 6"
31005	Straight Pipe Wrench, Cast Iron, 8"
31010	Straight Pipe Wrench, Cast Iron, 10"
31015	Straight Pipe Wrench, Cast Iron, 12"
31020	Straight Pipe Wrench, Cast Iron, 14"
31025	Straight Pipe Wrench, Cast Iron, 18"
31030	Straight Pipe Wrench, Cast Iron, 24"
31035	Straight Pipe Wrench, Cast Iron, 36"
31040	Straight Pipe Wrench, Cast Iron, 48"
31045	Straight Pipe Wrench, Cast Iron, 60"



SOCKET SETS



#19134 ~ 12 PIECE - 3/8" DRIVE SOCKET SET

CONTAINS:

Part #	Description
VinylGrip	12oz.
11008	6 Pt. Std.Skt. 3/8"
11009	6 Pt. Std.Skt. 7/16"
11010	6 Pt. Std.Skt. 1/2"
11011	6 Pt. Std.Skt. 9/16"
11012	6 Pt. Std.Skt. 5/8"
11013	6 Pt. Std.Skt. 11/16"
11014	6 Pt. Std.Skt. 3/4"
11015	6 Pt. Std.Skt. 13/16"
11412	Spark Plug Skt. 5/8"
11905	3" Extension
11910	6" Extension
1190	Ratchet Quick Release Metal Box

#19211 ~ 16 PIECE - 1/2" DRIVE SOCKET SET

CONTAINS:

Part #	Description
12209	12 Pt. Std.Skt. 7/16"
12210	12 Pt. Std.Skt. 1/2"
12211	12 Pt. Std.Skt. 9/16"
12212	12 Pt. Std.Skt. 5/8"
12213	12 Pt. Std.Skt. 11/16"
12214	12 Pt. Std.Skt. 3/4"
12215	12 Pt. Std.Skt. 13/16"
12216	12 Pt. Std.Skt. 7/8"
12217	12 Pt. Std.Skt. 15/16"
12218	12 Pt. Std.Skt. 1"
12219	12 Pt. Std.Skt. 1 1/16"
12220	12 Pt. Std.Skt. 1 1/8"
12222	12 Pt. Std.Skt. 1 1/4"

CONTAINS:

Part #	Description
12810	6" Extension
12820	Flex Handle 15"
12800	Ratchet Quick Release Metal Box

Construction Products

6232-6 ~ DEEP CUT PORTABLE BAND SAW



Milwaukee's Deep Cut Portable Band Saws have a cutting capacity of 4-3/4 inch x 4-3/4 inch. With high torque and a powerful motor this band saw will maintain a steady, optimum blade speed. The excellent balance, high visibility and quick blade change system make this band saw easy to work with. Using an all ball and roller bearing construction, and worm gear and chain drive mechanism this tool is built to last. A self-lubricating system is used for maximum wear resistance and long life. No oiling is needed. Includes Band Saw, carrying case, and one 14 TPI Bi-Metal Blade.

- Cuts up to 4-3/4 inch x 4-3/4 inch rectangular stock and 4-3/4 inch round stock
- 6 amp, AC only
- Trigger speed control: 0-350 sfpm
- Uses standard 44-7/8 inch x 1/2 inch x .020 inch band saw blades

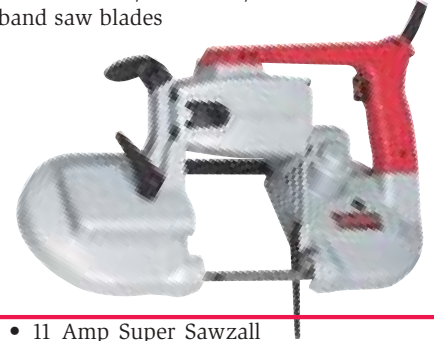

6521-21 ~ 11 AMP ORBITAL ACTION SUPER SAWZALL

Orbital action has been added to the heavy duty 11 amp Super Sawzall for even more aggressive cutting applications in wood. The Orbital Action Selector allows the user to set the degree of orbital action for faster cutting in thick materials. This tool incorporates the patented gear protection system which absorbs high impact forces caused by sudden blade lock-up thereby extending the life of the tool even under the most extreme cutting conditions. The patented counter balance mechanism makes the Super Sawzall the smoothest operating, most vibration free saw in the world. Trigger Speed Control allows the operator to match the speed of the tool to the application. The new Heavy Duty Steel Quik-Lok Blade Clamp System enables the user to change blades fast and easy without the use of a Hex Wrench. Standard equipment includes a steel carrying case and two blades.

- 11 Amp Super Sawzall
- Orbital Action
- Speed Control 0-3200 SPM
- Counter Balanced/Gear Protection Systems

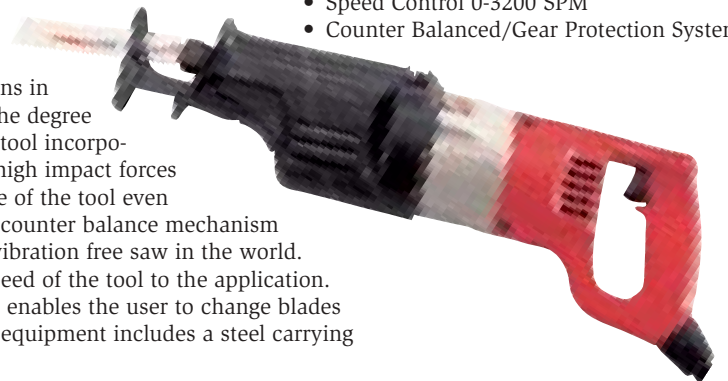

6065-6 ~ 7 IN./9 IN. SANDER

This Powerful 15 amp, 5,000 RPM, 3.5 HP Sander provides high performance under severe applications. As a sander, this tool can be used with a 9 inch backing pad for removing paint or rust from metal, plastic and fiberglass surfaces. Spiral Bevel Gears transfer maximum torque for heavy duty jobs. Spring loaded Recessed Spindle Lock assists in easy accessory changes. Sold as a Sander, this tool can be converted to a grinder by purchasing a 7 inch or a 9 inch guard which is easily attached to the tool. Grinding applications remove more material and may be used to shape metal. Includes tool, side handle, flange and washer.



- Powerful 3.5 hp, 15 amp, motor
- 7 inch or 9 inch capacity, 5,000 RPM, AC-DC
- Spiral bevel gearing for performance and durability
- Sander may be converted to grinder by using the proper wheel guard

6145 ~ 4-1/2 IN. SANDER/GRINDER, 5.5 AMP, 10,000 RPM, 1/2 X 13 SPINDLE

An old Milwaukee reliable, the 6145 4-1/2 inch 5.5 amp grinder gets into tight spaces where other grinders can not. Its low profile and light weight make it perfect for those lighter duty sanding and grinding projects. The tool is double insulated (two prong cord) and uses a 1/2-13 threaded arbor. Like its heavy duty big brothers, it also has spiral bevel gears for optimum transmission of torque to the work piece. The comfortable body grip style is easy to hold onto and in conjunction with the supplied side handle allows for maximum operator control. The side handle can be attached in three locations. The wheel guard can be moved around the spindle (without the use of tools) for greatest operator protection. Sold as a grinder with guard, this tool can be used as a sander when a 4-1/2 inch backing pad and disc are attached. Includes tool, guard, grinding wheel, spanner wrench and side handle.



- 5.5 amp, 10,000 RPM, AC-DC
- Spiral bevel gearing for performance and durability
- All ball and roller bearing construction
- Tool-free adjustable wheel guard

Construction Products



1660-6 1/2 IN. COMPACT DRILL 450 RPM

Big power in a compact drill, the Milwaukee 1660-6 is easy to use with its extra long handles. This drill is made for 2 handed operation which is nice for large hole drilling or material mixing, this drill has the power to handle it. This unit features a 450 rpm operating speed, a good speed for large bits or any hi-torque application. Includes drill and pipe handle.

- 1/2 in. capacity in steel
- 450 rpm, reversing
- Powerful 7 amp motor
- Heat treated gears are Helical-Cut for quiet performance

0234-6 ~ 1/2 IN. MAGNUM DRILL

This Heavy-Duty Magnum drill is built for industrial/construction applications. It features raw power with a Milwaukee built 5.5 amp motor, 0-1200 rpm trigger speed control, reversing, and a Quik-Lok cord that can be quickly removed from the drill for storage or service replacement. Another exclusive feature is the brush cartridge system, with a set of spare brushes, that allows you to change brushes in less than one minute. Use this tool with a variety of accessories to drill into wood, metal, plastics and composites. Milwaukee products have a limited warranty.

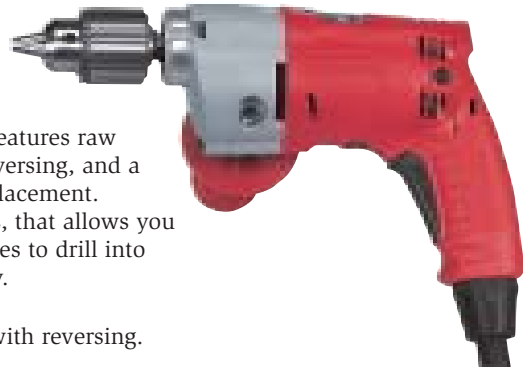

- 5.5 amp motor, 0 to 850 rpm, trigger speed control with reversing.
- Heavy-Duty industrial chuck.
- 8' 3-wire Quik-Lok® cord with easy detachment for storage and service
- Exclusive brush cartridge system changes brushes in less than one minute.

1107-6 1/2 D-HANDLE DRILL 0-500 RPM

If More Power is what you need, then look no further than the Milwaukee D-handle line of drills. With 7 amp motors and heat treated metal gears, these are truly the choice of the professional. The 1107-6 features 0 to 500 rpm, Quik-Lok cord and can be used with our right angle drive attachment to increase versatility. Includes drill, chuck key and rubber flex holder.



- 1/2 in. capacity in steel
- Trigger speed control: 0-500 rpm, reversing
- Powerful 7 amp Milwaukee built motor
- Quik-Lok® cord sets detach for tangle-free carrying and storage. 8' length standard, 25' length optional

Construction Products

DW995K-2 HEAVY-DUTY XRP™ 18V 1/2" (13MM) ADJUSTABLE CLUTCH DRILL/DRIVER KIT



FEATURES:

- 1/2" Single Sleeve Keyless Chuck
- Automatic Spindle Lock
- DEWALT-Built High Torque Motor
- Anti-Slip Comfort Grip
- Extended Run-Time XR +™ PACK Batteries
- Powered by DEWALT's 18V "system" of battery packs
- 400 inch lbs. of torque
- 5 steel-planet transmission and copper-plated switch provide job site durability
- Variable speed, reversing; 0-450/0-1,600 rpm
- 2 Batteries

DW998K-2 HEAVY-DUTY XRP™ 18V 1/2" (13MM) ADJUSTABLE CLUTCH HAMMERDRILL/DRILL/DRIVER KIT



FEATURES:

- 1/2" Single Sleeve Keyless Chuck
- Automatic Spindle Lock
- DEWALT-Built High Torque Motor
- Anti-Slip Comfort Grip
- Extended Run-Time XR +™ PACK Batteries
- 3 tools-in-one: Hammer/Drill/Driver
- Carbide-Tipped Chuck Jaws
- Powered by DEWALT's 18V "system" of battery packs
- 5 steel-planet transmission and copper-plated switch provide job site durability
- Variable Speed Reversing; 0-450/0-1,600 rpm And 0-5,100/0-18,000bpm
- 2 Batteries

DW531K HEAVY-DUTY 1-1/2" (38MM) SPLINE ROTARY HAMMER KIT

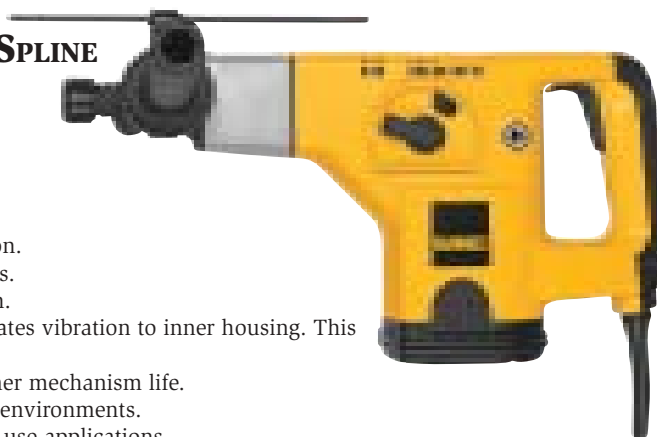

FEATURES:

- Built for continuous, large, deep hole drilling.
- Excellent for moderate chipping jobs.
- 9.4 Amp motor provides high performance and overload protection.
- Stop rotation with Bit Lock™ allows user to "unwind" jammed bits.
- Hard-hitting hammer mechanism for fast and efficient penetration.
- Dual wall housing construction with rubber mounts between isolates vibration to inner housing. This reduces user-felt vibration causing less fatigue.
- Multiple seals prevent dust from entering tool for extended hammer mechanism life.
- Switch and brushes designed for long life in dusty, contaminated environments.
- Highly efficient cooling system protects tool in tough, continuous-use applications.
- 360° Side Handle is easily adjustable for user preference or use in tight spaces without moving depth rod.
- Rear Mount for side handle reduces the amount of bending over required by users in down drilling applications.
- Factory set clutch reduces sudden, high-torque reactions if bit jams.
- Modular design provides easy access to switch, cordset, brushes, motor and gearcase for ease of service.
- Loaded speed: 320 rpm
3,000 bpm

DW567K HEAVY-DUTY 1" VSR SDS ROTARY HAMMER KIT



FEATURES:

- Compact size for easy access into tight spaces.
- D-handle grip configuration for optimal control overhead.
- 6.9 Amp motor provides high performance and overload protection.
- Hard-hitting hammer mechanism for fast and efficient penetration.
- 360° Side Handle is easily adjustable for user preference or use in tight spaces.
- Fully sealed gearbox engineered for long life by keeping grease in and dust out.
- User-friendly weight for extended periods of overhead drilling.
- Reverse feature assists in removal of Tapcon™ type fasteners.
- Rotation-only mode for wood and metal drilling (using SDS-to-Round Shank Adapter).
- Chiseling (Hammer-Only) mode allows user to perform light chipping applications such as removal of mortar splatter.

DH38YE 1-1/2" ROTARY HAMMER SPLINE SHANK



- Powerful 8 AMP motor increases productivity
- Sealed grease system insures minimal maintenance
- Auto-stop carbon brushes to protect armature
- Dust-proof cover for extended maintenance-free operation
- Impact energy of 5.2 ft./lbs.
- No-load speed of 380 RPM and 2800 BPM
- Core bit of 4-1/8".
- Weighs 16.6 lbs.

DH24PB - 2 MODE, 15/16" ROTARY HAMMER SDS PLUS, E.V.S., REVERSIBLE

- New more powerful 5.7 AMP motor
- 2 modes of operation - hammer/drill and drill only
- Lightweight - only 5.1 lbs.
- Impact energy of 1.5 ft./lbs.
- No-load speed of 0-1000 RPM and 0-4400 BPM
- Steel capacity of 1/2", wood capacity of 1-1/4" and concrete capacity of 15/16"
- Core bit of 2"



DH24PE - 1 MODE, 15/16" ROTARY HAMMER D-HANDLE, SDS PLUS, E.V.S., REVERSIBLE

- Electronic stepless variable speed control for improved drilling efficiency and control
- Quiet cool air flow reduces operating noise to only 87 dB
- Compact and lightweight D-handle design
- New dust proof trigger switch for optimum reliability
- Impact energy of 1.6 ft./lbs.
- No-load speed of 0-1050 RPM and 0-4400 BPM
- Weighs only 5.3 lbs.
- Steel capacity of 1/2", wood capacity of 1-1/4" and concrete capacity of 15/16"
- Core bit of 2"



Construction Products

HITACHI
POWER TOOLS

CC12Y

12" CUT-OFF SAW

- Portable, AC/DC
- Auto-stop carbon brushes protect armature and extend tool life
- Cutting wheel is replaceable without removal of base
- Wide base for extra cutting stability
- Weighs only 24 lbs.
- Max depth of cut is 4"
- 1" Arbor
- Powerful 15 AMP motor for greater cutting efficiency runs at a no-load speed of 5000 RPM



HITACHI
POWER TOOLS

CC14SC 14" CUT-OFF MACHINE

- Portable, AC/DC
- Powerful 15 AMP motor for greater cutting efficiency runs at a no-load speed of 3200 RPM
- Lightweight (37 lbs.) and portable for any work site
- Quick release vise for fast and easy material change
- Durable steel base for extra cutting stability
- Max depth of cut is 4-1/2"
- 1" Arbor

HITACHI
POWER TOOLS

H85, DEMOLITION HAMMER, 1 1/8" HEX, 73 LBS., OIL

- Powerful 12.2 AMP motor for heavy duty demolition
- Oil bath lubrication system extends tool life
- Automatic oiling system with unique "air-pressure oil control" enables extended use without oiling
- Auto-stop carbon brushes protect armature and extend tool life
- 950 BPM
- Impact energy of 37.6 ft./lbs.



Construction Products



- 1/2 in. square drive, 6.8 amp motor
- 2400 rpm, 2800 bpm, 240 ft.-lbs. torque, reversing
- Heavy-duty rocker switch
- Easy access to brushes



9066-6 1/2 IN. SQUARE DRIVE IMPACT WRENCH

This hi-torque electric impact wrench has the power to turn even the rustiest bolt. With a 1/2 in. square drive, 6.8 amps of power and 240 ft./lbs. of torque, you have one serious driver. The convenient rocker switch makes forward/reverse operation a snap and it only weighs 6 lbs. The easy access brushes make for quick changes. This is a well balanced and very powerful unit that can be used under the toughest of conditions.



WH16

1/2 INCH IMPACT WRENCH SQUARE DRIVE

FEATURES:

- Powerful 5 AMP motor with 217 ft./lbs. of tightening torque
- Anti-vibration and heat-proof motor adds comfort and safety
- Industrial pin detent socket retainer keeps sockets straight and tight
- Exclusive long-life hammer system provides extended maintenance free operation
- No-load speed of 1700 RPM
- Impact Rate of 2000 IPM
- Max torque of 217 ft./lbs.

WH22

3/4 INCH IMPACT WRENCH SQUARE DRIVE

FEATURES:

- Powerful 10 AMP motor with 434 ft./lbs. torque for faster tightening
- Anti-vibration and heat-proof motor for comfort and safety
- Industrial pin and ring socket retainer keeps sockets straight and tight
- Exclusive long-life hammer system provides extended maintenance-free operation
- Convenient side handle for better control during high torque applications
- No-Load speed of 1600 RPM and Impact Rate of 1800 IPM
- Max. torque of 434 ft./lbs.
- Includes: Hex Wrench, Hex Socket, Metal Case and Side Handle



DW290

HEAVY-DUTY

1/2" (13MM) IMPACT WRENCH

FEATURES:

- AC/DC forward/reverse rocker switch
- Delivers full power; 240 ft. lbs. of torque in forward and reverse
- Detent pin for secure socket retention
- Also available in 220V
- Ball-bearing construction
- Amps 7.5 amps



Construction Products

FLAT D-RUNG EXTENSION LADDERS

300 LBS. TYPE IA ~ D6200-2/D6200-1 SERIES
SIZES AVAILABLE IN 16' TO 40'

ORANGE, ELECTRICALLY NON-CONDUCTIVE SIDE RAILS

- Mar-resistant molded end caps
 - Pre-pierced holes for easy field installation of accessories
 - External guides at top of base section securely interlock rails. Two sets on 36' and 40' models.
 - 36' and 40' have a 250 lbs. duty rating
 - Heavy duty pulley with rope
 - Direct rung to rail connections
 - Interlocking side rails
 - Slip-resistant Traction-Tred® D-rungs
 - Base and fly separate easily to use base section as single ladder
 - Rugged gravity spring locks operate smoothly
 - Internal guides on bottom of fly section securely interlock rails
 - Rope clamp ties rope to rung
 - Durable rail shield bracket and shoe with Shu-Lok®, slip-resistant pad and spur plate
 - Molded rung braces
- *Exclusive Alflo® rung joint means Twist-Proof® performance



WERNER

STEPLADDERS

300 LBS. TYPE IA ~ 6200 SERIES
SIZES AVAILABLE 3' TO 12'

ORANGE, ELECTRICALLY NON-CONDUCTIVE SIDE RAILS

- Tool-Tra Top® - with drill holster and convenient tray for tools
- 4 rivets attach top to each front rail
- Shoulder bolt and nut on top hinge
- Back-up plates reinforce all top connectors
- Handy paint can hanger on back side of top
- Top steps and rear horizontals are knee-braced
- Double riveted, slip-resistant Traction-Tred® steps
- Internal Pinch-Proof™ spreaders
- Full set of rear horizontals spaced one per foot
- EDGE - molded brace and foot pad combination provides enhanced bracing strength and increased protection against damage
- Energy Diffusing Geometry
- Every rivet backed up by metal part or washer to protect rails
- Optional yellow molded pail shelf kit, model no. 76-2



1000WATT HALOGEN TELESCOPING WORKLIGHT

- Telescopes from 40" to 67" with "Easy Grip" locking nuts
- Cord storage brackets on pole
- Weatherproof on/off switch
- Complete with two 500w halogen bulbs
- Limited warranty; UL & CUL Listed

Part #	Description
L-14	1000watt worklight



500WATT HALOGEN "GLADIATOR" SPRING MOUNTED

- Professional grade construction
- Heavy duty style roll cage gives maximum protection
- Extra bulb storage tube
- Light housing supported by stainless steel springs providing protection
- Complete with two 500w halogen bulbs
- Limited warranty; UL & CUL Listed

Part #	Description
L-112	500watt Gladiator



500WATT HALOGEN PORTABLE WORKLIGHT

- "S" stand with foam grip handle
- Complete with 500w halogen bulb
- Limited warranty; UL & CUL Listed

Part #	Description
L-18	500watt portable worklight



500WATT HALOGEN S-HANDLE POWER LIGHT

- Heavy-duty construction
- Large face frame and housing for cool operation and longer bulb life
- Extra bulb storage tube
- 3/4" stand with foam handle and foam feet
- Weatherproof on/off switch
- Complete with two 500w halogen bulbs
- Limited warranty; UL & CUL Listed

Part #	Description
L-38	500watt S-handle power light



Construction Products

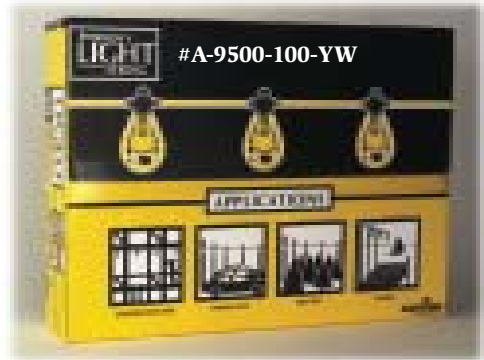

**BE SURE TO ASK A
POWERPLUS TEAM MEMBER
ABOUT LOCKING AND NON LOCKING
PLUGS AND RECEPTACLES**



Part #	Description	AWG	Length	Amps	Watts
5266P	Plug Male U-G			20	
5269C	Plug Female U-G			20	
5984	U-Ground Cord End-Male			15	
5985	U-Ground Cord End-female			15	
A-9500-100-YW	Temporary Light Strings, In/Outdoor, Plastic cage, SJTW	14/2	100'		includes 10,150W Sockets
C-4314-050-TEABX	Outdoor Extension Cord, 3-Conductor, SJTW	14/3	50'	15	1875
C-4314-100-TEABX	Outdoor Extension Cord, 3-Conductor, SJTW	14/3	100'	13	1625
C-4312-050-YW	Outdoor Extension Cord, 3-Conductor, SJTW	12/3	50'	15	1875
C-4312-100-YW	Outdoor Extension Cord, 3-Conductor, SJTW	12/3	100'	15	1875
A-9315-50-YW	Outdoor Extension Cord, Locking Connector, SJTW 600 Volt wire	12/3	50'	20	1875
A-9315-100YW	Outdoor Extension Cord, Locking Connector, SJTW 600 Volt wire	12/3	100'	20	1875
A-8312-002-YW	Adapter, RHINO-HIDE® Power Block, STW	12/3	15		1875
A-1449-002-YW	Adapter, RHINO-HIDE® Locking connector,Power Block, STW	12/3	15		1875
A-1446-009-YW	Adapter, Locking Connector to U-ground, STW	12/3	15		1875
A-1447-009-YW	Adapter, U-ground to Locking Connector, STW	12/3	15		1875
A-1473-020-YW	Adapter, U-ground connector, "Y" adapter, STW	12/3	15		1875
A-1479-020-YW	Adapter, U-ground connector, "W" adapter, STW	12/3	15		1875
H-1194-003-AS	Surge Protector, 6-outlet, 210 Joules, Slendor Plug cord		3'		
B-0317-000-IV	Adapter, 3-outlet adapter				
B-0318-1/C-CL	Adapter, Quick Check Lighted Adapter, Single-outlet				
A-1399-006-YP	Ground Fault Circuit Interrupters (GFCI), SJTW	14/3	15		1875
A-1402-003-YW	Ground Fault Circuit Interrupters (GFCI), STW, 600 Volt wire	12/3	15		1875
A-1404-003-YW	Ground Fault Circuit Interrupters (GFCI), STW, 600 Volt wire	12/3	20		2500

Color Code

YW - Yellow, YP - Yellow/Pro-grade, TEABX - Teal, IV - Ivory, CL - Clear, AS-Ash, CL - Clear



Construction Products



YG 2600D



THE YG2600'S 171CC FOUR-STROKE OHV ENGINE DELIVERS A POTENT COMBINATION OF 2600 WATTS (MAXIMUM AC OUTPUT, WITH 6900 WATTS SURGE CAPACITY) AND OUTSTANDING FUEL ECONOMY.

- Up to 17.5 hours of continuous running time on each tank of gas without refueling.
- Dependable, maintenance-free T.C. ignition system and brushless AC alternator.
- Automatic Oil Warning System shuts off engine if oil level runs low.
- Oversize muffler with USFS-approved spark arrestor ensures extra-quiet operation.

YG 4000DX



A LOT OF PEOPLE NEED THE CONVENIENCE OF RUNNING BOTH 120 AND 240 VOLTS - BUT THEY DON'T WANT TO PAY THE PREMIUM, YAMAHA JUST MADE DUAL VOLTAGE MORE ATTAINABLE IN THE YG4000DX GENERATOR. IT DELIVERS EVERYTHING YOU WANT IN A GENERATOR - HIGH POWER OUTPUT AND QUIET OPERATION, ALL IN A COMPACT PACKAGE.

- Provides 120 and 240 volt operation for enhanced versatility
- Monitors fuel level and lets operator know how much fuel is left.
- Automatic Oil Warning System shuts off engine if oil level runs low.

YG 4600D



THE YG4600D A 301CC OHV FOUR-STROKE ENGINE DELIVERS FULL-TIME DUAL 120/240-VOLT OPERATION TO PRODUCE 4600 WATTS MAXIMUM AC OUTPUT (WITH 12,000 WATTS SURGE CAPACITY).

- Large capacity fuel tank delivers up to 10.1 hours of dependable, continuous power.
- An economy idle system slows engine speed for optimal fuel efficiency during no-load situations.
- Automatic voltage regulator monitors output for clean, accurate delivery.
- Oil-filled, non-fused thermal breaker protects AC circuit in case of overload.
- 4-point antivibration mounting system and oversize muffler ensure smooth, quiet operation.

YG 6600D



THE YG6600D DELIVERS FULL-TIME DUAL 120/240-VOLT OPERATION WITH A POTENT 357CC OHV FOUR-STROKE ENGINE GENERATING 6600 WATTS MAXIMUM AC (18,000 WATTS OF SURGE) output.

- Up to 8.3 hours of continuous operation on a tank of gas.
- Low Oil Warning System with automatic engine shut-off.
- Economy idle feature lowers engine speed and save fuel during no-load situations.
- No-maintenance T.C.I. system and brushless generator ensure years of dependable, trouble-free service.
- Automatic voltage regulator ensures precise, clean output.

Construction Products



89

Storage Capacity: 47.8 Cubic Feet
Shipping Weight: 337 lbs.



Introducing The
NEW **WATCHMAN®IV** LOCK SYSTEM
for chests!

FEATURING:
**One Padlock With Two Point
Dead Bolt Latching!**

**These 2 chests can be turned into
mobile units by adding casters.
Ask a POWERPLUS TEAM MEMBER
for information on accessories.**



4824

Storage Capacity: 16 cubic feet
Shipping Weight: 158 lbs.
Use Model 21 Accessory Tool Tray

**Please make note the
products on this page
are NOT available at all
PowerPlus locations.**



63 STORAGE MASTER® ROLLING WORK BENCH

This rolling work bench has a RED POWDER COAT FINISH and the work top and bottom are 12 gauge steel. Cabinet is 16 gauge steel. Each drawer features ball-bearing drawer slides that have a 100 lb. load rating. Casters are 6" polyurethane with brakes.

THE STORAGE MASTER® MECHANICS CHEST FEATURES:

- 4-2 1/2" deep drawers, 1- 6" deep drawer,
- 3-1" deep drawers and 1- shelf.
- Load capacity: 1000 lbs.
- Shipping Weight: 352 lbs.

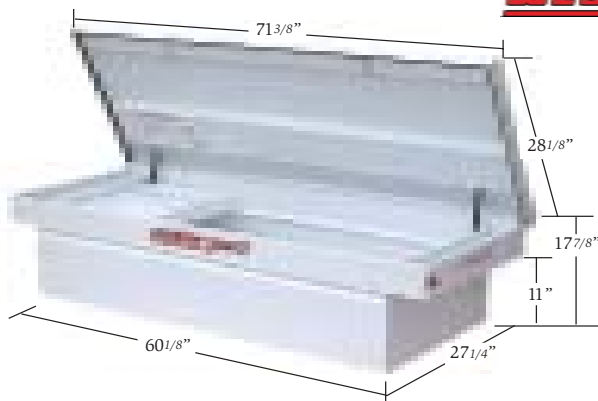

116-3 STEEL SADDLE BOX

STEEL SADDLE BOXES suspend from the side rails of the truck which allows plenty of room underneath for long materials that require the full length of the truck bed. Available for full size and mini pickups.

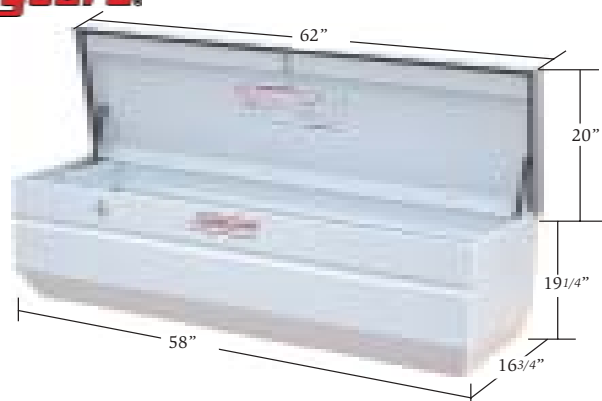

665-3 STEEL ALL-PURPOSE CHEST

STEEL ALL-PURPOSE CHESTS mount right to the bed of the truck and their angled design makes it perfect for fifth wheel mounts. The WG-Ti® BRITE WHITE Finish and the stainless steel hinge assure years of good looks and trouble free use.



Environmental Products



H500V

HEPA-AIRE® Model H500V

At just 42 lbs., including filters, the H500V is our most lightweight and portable model. It is ideally suited for use in confined spaces, where space is limited. This "mighty mite" is designed to produce up to 450 cfm, yet draws only about 1.25 operating amps and can be easily hand-carried to the job site.

- Variable speed controller (100-450 cfm)
- Filter change indicator light
- Maintenance-free motorized impeller
- Internally protected, 99.97% certified HEPA filter
- Recessed control panel
- Top carrying handle Plastic feet protect surfaces
- Uses 8" flex duct

HEPA-AIRE® Model H1000V



H1000V

The compact, full-feature H1000V is designed for use in smaller rooms where less airflow is needed, and a larger machine will not fit. With its numerous "bells and whistles" and its professional, high-tech appearance, the H1000V is well-suited for a wide range of commercial or retail applications for high efficiency air filtration. The fully variable speed controller (100-800 cfm) enables the user to "tune in" airflow to the specific needs of the work area.

- Aircraft aluminum cabinetry with gasketed seams
- Solid rivet construction
- Modular, recessed control panel with 1-plug connection
- Internally protected, 99.97% HEPA filter
- Filter change indicator light
- Weighs just 79 lbs.
- 31 3/8" L x 17 3/4" W x 24 1/2" H

HEPA-AIRE® Model H2000HP



H2000HP

The H2000HP "contractors" model is designed to provide the budget-conscious user with a more basic alternative to the full-feature H2000A. It delivers the same superior airflow, but with more economical construction and components, and fewer "bells and whistles".

- Airflow independently tested and certified at over 2,000 cfm
- Galvanized steel cabinetry
- 2-speed motor
- Visual filter change indicator lamp
- Internally protected, 2,000 cfm-rated 99.97% HEPA filter
- Recessed control panel
- 2 fixed and 2 locking swivel casters
- Caster support rails

Part #	Description
H500V	HEPA-AIRE® 100-450 CFM, HEPA-air machine
H1000V	HEPA-AIRE® 100-800 CFM, HEPA-air machine
H2000HP	HEPA-AIRE® 1000/2100 CFM, HEPA-air machine

ACCESSORIES

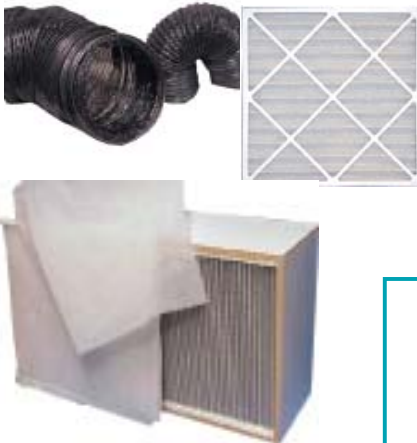

Part #	Description	Size
P2424-50	Primary Filter	24" x 24"
S2424-12	Secondary Filter, Pleated	24" x 24"
R2424-12	Secondary Filter, Ring Panel	24" x 24"
H2424	HEPA Filter	24" x 24" x 12"
C2424	Carbon Filter	24" x 24"
H2020-08	Flex Duct	8" x 25'
H2020-10	Flex Duct	10" x 25'
H2020-12	Flex Duct	12" x 25'

Accessories & Filters Available for All Air Filtration Machines
 Please contact an
PowerPlus TEAM MEMBER
 for additional information.

Environmental Products



Force Air

FA2000EC Features:

- Heavy Duty aluminum cabinet
- Modular control panel and service
- Sealed control box
- HEPA filter is locked in
- Four heavy duty swivel casters 2 w/locks
- Rugged carrying handles

FA2000EC Benefits:

- Lightweight, durable and rust resistant
- Control panel unplugs for easy removal
- Eliminates leakage around gauges
- Assures a positive seal around HEPA filter
- Provides easy portability
- Provides easy portability



PHANTOM

PH2000 Features:

- Heavy Duty Galvanized Steel
- Modular control panel and service
- Sealed control box
- HEPA filter is locked in
- Four heavy duty swivel casters 2 w/locks
- Rugged carrying handles

PH2000E Benefits:

- Durable and rust resistant
- Control panel unplugs for easy removal
- Eliminates leakage around gauges
- Assures a positive seal around HEPA filter
- Provides easy portability
- Provides easy portability



FA600

FA600 Features:

- Mini Helic Pressure Gauge
- Four (4), 2" swivel casters
- Two (2), easy lift handles
- One (1), 10" discharge ring
- Two speed switch

Part #	Description
FA2000E	Force Air 1000/1975 Air Filtration Machine
PH2000	Phantom 1000/1975 Air Filtration Machine
FA600	Forced Air 400/600 Air Filtration Machine



PowerPlus also carries a complete line of extension cords and GFCI protectors for use with AFD's and other equipment.

Environmental Products

Dispos-A-Con™ Decontamination System

Dispos-A-Con™ 9000 is a low-cost, lightweight, disposable decon that facilitates decontamination. It is remarkably strong and sturdy. Entrances and exits are triple-flapped 6-mil poly and the walls are solid double-wrapped 6-mil poly. The shower room has an internal boot extending 12" up on each side to insure leak-proof operation.

- Erect in 15 minutes
- Dispose in 5 minutes
- Meets EPA & OSHA guidelines
- Reusable hardware
- Rugged construction



Mfg. & Sales



Part #	Description
9000	Dispos-A-Con™ 9000 — 3 rooms: 1-shower/1-clean/1-dirty
1400	Dispos-A-Con™ 14-pole set (reusable)
10	Shower head - single inlet (reusable)

Klean Pop™ #6439



Klean Pop was developed in response to a growing need for an easy-to-use, quality decontamination shower at a good value. Klean Pop assembles quickly and easily, and has quality components with minimal joints for lasting durability. Klean Pop collapses into its base, making transportation and storage of the unit easy.

- Rugged Aluminum construction
- Removable floor
- Mildew resistant shower curtain
- Lightweight
- Wheels on base for easy transportation
- Modular poles fit into base



HF-SE2 Portable Shower



Features:

- Lightweight aluminum construction
- Two panel collapsible construction
- Shower head with 5' adjustable hose
- 100 Micron drain filter
- Compact unit
- Removable curtain
- Quick release pin system
- Removable bottom basin
- Heavy duty carrying handles

Benefits:

- Durable and rust resistant
- Allows unit to collapse to 50.5" tall
- Allows cleaning of bags and equipment
- Allow removal of large particles, dust, scum and fibers
- Easily transported, easily stored
- Easily removed for decontamination
- Allows one person to set up shower in seconds
- Allows shower to be completely decontaminated
- Provides easy portability



HF-2

Features:

- Heavy duty [.080] aluminum cabinet
- Electrical components installed in enclosed box
- Galvanized plumbing
- Built in GFCI
- Vacuum switch
- Motor

Benefits:

- Lightweight, durable and rust resistant
- Keeps dirt & water off electrical components
- Provides long life and durability
- Protection from electrical shock
- Prevents motor burn out
- Low AMP draw

SHOWER ACCESSORIES

Part #	Description	Pack
AMRR909QT	PowerPlus hair & body shampoo, 32 oz.	ea.
AMRR909GAMRL	PowerPlus hair & body shampoo, gallon	ea.
SBT-15	PowerPlus Disposable Towels	300/cs.
WF9-5	Water filter, 2 3/4" D x 9 3/4" L, 5 Micron	ea.
WF9-50	Water filter, 2 3/4" D x 9 3/4" L, 50 Micron	ea.



Additional Accessories Available for All Models
Please contact an PowerPlus for additional information.

Environmental Products

GM 80 Dry HEPA Vacuum

The versatile GM 80 safely collects lead, asbestos, silica and other hazardous dusts and fine powders. A 4-stage, graduated filtration system includes a 2 1/4-gallon paper bag, cotton main filter, AES polycomposite microfilter and HEPA exhaust filter. Equipped with a HEPA filter, the GM 80 retains 99.97% of all particles to 0.3 microns in size. For ultrafine filtration, an ULPA (Ultra Low Penetration Air) filter is available to capture 99.999% of particles to 0.12 microns. Ideal for cleanroom environments. Interference suppressed for safe use around electronic equipment, the lightweight GM 80 can be used in portable or stationary applications. Standard package includes: detachable trolley, 6'6" plastic hose, combination nozzle, two straight steel wands, 3" round dust brush, crevice cone, 5" upholstery nozzle, 30' power cord and package of five paper bags. Optional variable speed control is available to adjust the vacuum's suction power from 0 to 100% power so it may be used with glovebags.



HEPA BACK VACUUM

The HEPA BACK VACUUM rests comfortably on the hips of the operator. Thanks to its unique articulated design, it flexes with the spine as the operator bends down or moves from side to side. The motor is located to correspond to the body's own center of gravity. This reduces strain, meaning fewer lost days due to sickness or injury.

The revolutionary ergonomic design from Nilfisk Advance now enables cleaning staff to carry out their tasks in comfort. The lightness of the HEPA BACK VACUUM increases operator mobility and makes it easier to clean confined or cluttered areas, such as cinemas, or airplane interiors, and is ideal for daily office cleaning.

- Robust and reliable construction ensures long service.
- Belt design ensures even weight distribution.
- Motor located in lower half of the HEPA BACK VACUUM, ensuring a low center of gravity.
- Low exhaust air velocity - minimum disturbance of light materials in the vicinity.
- Hose coupling adjustable for left or right-handed use.
- Electro nozzle outlet for deep cleaning of carpets.
- HEPA filter available-ideal for dust free vacuuming.



VT60 WET/DRY HEPA VACUUM

The latest in filtration technology, the VT60 requires no filter change between wet and dry collection. A graduated filtration system includes main filter tubes that are water-, mildew-, rot- and corrosion-resistant. They require minimal maintenance and may be cleaned by simply wiping them off. Three collection options include direct collection into the 15-gallon vacuum tank, polyliner, or 5-gallon sealable pail. The VT60's motor can be adapted to sit on a 55-gallon drum to increase collection capacity. Suitable for applications requiring bulk, nuisance or hazardous material cleanup. A factory installed cleanroom option is available, enabling the VT60 to be taken into a Class 100 cleanroom environment. An air-powered model is also available. Standard package includes: 10' plastic or neoprene hose, double curved aluminum wand, 14" wet floor nozzle, 3" aluminum dust brush, 11" plastic crevice tool and package of 25 polyliners.



GD1010 COMMERCIAL VACUUM

Quiet and efficient the GD1010 is the way to go for daytime cleaning areas such as recreational facilities, building lobbies and hotels.

- Strong Suction power
- Lightweight
- Low noise level 60dB(A)
- Large dust capacity (9 litre)



ATRIX INTERNATIONAL, INC. *Omega Vac Abatement* #VACOMEGAH

The *Omega Vac Abatement* features a self-contained filtration system that captures hazardous particles as small as 0.12 micron. It includes two filter plugs, disposable bag and tie to prevent particles from escaping into the air or getting on hands and clothes when disposing filter. Plus, it's 6' clear hose allows the operator to visually check for any remaining particles in the hose.

The *Omega Vac Abatement* is made from a high-impact styrene construction for durability and long life. The lightweight and portable *Omega Vac Abatement* is ideal for glove bags, ladders or other hard-to-reach applications. It comes complete with a handy shoulder strap and accessories which store conveniently in the case cover.

- **Hepa Filter with a 0.12 Micron Retention** - For asbestos, fumes, lead residue, atmospheric dust, etc.. It includes two filter plugs disposable bag and tie for safe disposing of filter
- **Clear 6' Hose** - Provides an additional safety feature for the operator.
- **Flexible Goose -Neck** - To get to those hard-to-reach places.
- **Crevice Tool and Crevice Tool Brush** - To loosen fine particles in tight areas.
- **Utility Nozzle** - A 5 1/2" wide tool for cleaning floors and cupboards, etc.



Environmental Products

45ASB Dry Vacuum

Equipped with a powerful 1.5 horsepower motor and an extra large capacity HEPA filter system, the model 45 offers the air flow efficiency costing three times as much. The model 45 is manufactured to the same high standards as our large industrial HEPA vacuums, so it will withstand years of hard use.

Features:

- High quality, 1.5 horsepower bypass motor for fast, superior pick up and long life.
- High efficiency “drop-in” style HEPA filter individually certified to have a minimum efficiency of 99.97% at .3 microns (based on D.O.P. tests)
- With Pullman-Holt’s exclusive “never-clog” dacron bag for superior pre-filtration.
- Blow molded poly canister with low center of gravity design prevents tipping.
- Positive locking, full swivel hose connection system for easy handling and operation.
- Low noise allows for use in sound sensitive areas.
- 25 foot power cord. • Tool Kit included

102ASB12P Wet/Dry Vacuum: This powerful 2 horsepower, 2 stage long-life motor makes this HEPA vacuum a true “work horse” for heavy duty service in professional abatement work. The 102ASB offers superior vacuum recovery, ranging from dry, light particulates, to wet, heavy debris. 102ASB is a heavy duty poly tank vacuum. Pullman-Holt HEPA vacuums exceed all EPA and OSHA filtration standards.

Features:

- High Efficiency “Drop-in” style HEPA filter individually certified to have minimum efficiency of 99.99% at .3 microns (based on hot D.O.P. tests)
- Air seal gasket between the motor head and tanks forms a positive lock fit. 25 foot power cord. • U.L. listed and CSA approved.
- Polyester prefilter is located on the bottom of the HEPA filter, and is held firmly in place with Velcro fasteners.
- A Dacron filter bag covers the entire spacer sleeve and HEPA filter for three-stage filtration. Dacron materials sheds dust to maintain vacuum efficiency.

86ASB5D4C Wet/Dry Vacuum: The Model 86ASB is designed to work in tight areas, on scaffolding or any job site where a rugged steel compact vacuum is required. Easy to carry and transport. Can be converted to dry only as pictured above.

30ASB Dry Vacuum: This asbestos vacuum is ideal for elevated and hard-to-reach areas.

Features:

- Air seal gasket between the motor head and tanks forms a positive lock fit. • Includes complete set of tools
- High efficiency “Drop-in” style HEPA filter individually certified to have a minimum efficiency of 99.99% (86ASB) or 99.97% (30ASB) at .3 microns (based on D.O.P. tests)
- 25 foot power cord provided on 86ASB and 50 foot power cord on the 30ASB.



Accessories

Part #	Description
102ASB	Pullman Holt Wet/Dry 12 Gallon Vacuum
B160009	HEPA Filter for 102ASB
B700017	Pre-filter for 102ASB and 86ASB
B700306	Spacer Sleeve for 102ASB
B525410	Velcro Kit for 102ASB and 86ASB
B000517	Dacron Bag for all Pullman Holt Models Shown
B524253	Paper Collection Bag for 102ASB and 45ASB
86ASB	Pullman Holt Wet/Dry 5 Gallon Vacuum
B526520	HEPA Filter for 86ASB
B700408	Paper Collection Bag for 86ASB
45ASB	Pullman Holt Dry Only Vacuum
B702340	HEPA Filter for 45ASB
B702343	Retainer for Dacron Bag for 45ASB
B000394	Pullman Holt 2” Dusting Brush
B527094	Pullman Holt 14” Squeegee Tool
B527095	Pullman Holt 14” Floor Tool
B701615	Pullman Holt 11” Crevice Tool

Accessories & Filters Available for All Vacuum Models
Please contact an
PowerPlus TEAM MEMBER
for additional information.

Environmental Products

Dri-Eaz DrizAir™ 1200 Dehumidifier #F203

High-tech look for your customers, functional practicality for you! The DrizAir 1200 brings you into the next generation of commercial dehumidifiers! It looks like a dream and performs like a champion. Its high-tech appearance pleases customers, and its practical convenience features make it easy to transport and use.

- Powerful water removal — up to 15 gallons (120 pints) per day
- High-tech rotomolded durability — keeps its good looks longer than metal, with no sharp edges and no rusting
- Telescoping handle — ready when you need it, hides away when it's on the job or in the truck
- Easy to use — convenient touch-pad controls, integrated cord wrap for fast set-up and tear-down, and more
- Space-age handling — back skids, hand grips and large, semi-pneumatic tires make it a snap to take up and down stairs, over gravel, or in and out of your truck
- Fast ducting set-up — built-in duct ring for 4" regular or convenient LayFlat ducting



Dri-Eaz Rebel EX TurboDryer® #F215

Our most economical airmover makes it easy to get started in restorative drying with the extra long-life motor

- Powerful airflow — for minimal investment — rated at 2,400 max CFM
- Choice of 3 operating positions
- Optional kickstand and safe-grip carpet clamp
- Durable rocker switch — operates reliably even with rugged use



Dri-Eaz Sahara Pro TurboDryer® #F65-PRO

More built-in features to make your restoration job easier.

- 3-speed switch to give you more airflow control — from highest power to lowest noise.
- Built-in, patented, safe-grip carpet clamp — hold carpet in place without teeth that can easily damage wet carpet
- Thrifty energy use — just 4.7 amps saves money, lets you plug several into a single outlet
- 3 operating positions plus a kickstand — direct airflow and position for maximum drying efficiency



Moisture Counter™ #F84

The easy-to-use moisture meter with no pins!

- Non-destructive — leaves no puncture marks
- Low frequency electronic signals — detect moisture even through paint, vinyl wallpaper, tile, wood and drywall to a depth of 5/8"
- Measure varying densities — 3 settings you can adjust
- Compact and ready to use — comes with carry case and 9-volt battery



Dri-Eaz Wet Chec✓ #F213

- Unique — a small, light, consumer-level tool that detects moisture in carpets, walls and more
- Satisfy adjusters — now they can verify when your equipment needs to operate longer
- Customize with your label — easier than handing out your business card, and works a whole lot better
- Replaceable battery
- Economical enough to purchase by the case
- Give one to agents and other referral sources — plumbers, roofers, carpet retailers, waterbed stores, and others
- Make allies of customers — loan one to customers so they can track progress and justify additional rental days to adjusters



Part #	Description
F203	DrizAir 1200 Dehumidifier
F215	Rebel EX TurboDryer
F65-PRO	Sahara Pro TurboDryer
F84	Moisture Counter
F213	WetChec✓

*PowerPlus is a full line Dri-Eaz distributor.

DRI-EAZ
FIRST IN DRYING SOLUTIONS

Environmental Products

Sampling Pumps

Working in atmospheres likely to contain dangerous particulates requires reliable constant air monitoring. Now the standard in the industry, Allegro's Air Sampling Pumps provide dependable continuous monitoring of asbestos, lead, and other dangerous particulates.

This low-maintenance pump meets all OSHA and AHERA standards for air sampling safety. At less than 10 lbs., it is lightweight and easy to use. The rotary, oil-less, carbon vane pump has only one moving part for continuous draw and low maintenance. It has an adjustable regulator with a locked-in operating range of 3-20 lpm. The pump is complete with an adjustable aluminum tripod, five feet of vinyl tubing, inline filters, muffler jars, feet, handle and power cord with switch.

Part #	Description
9804	A100 Sampling Pump with stand
9804-88	A100 Sampling Pump without stand



BDX II Abatement Air Sampler

Designed for lead and asbestos monitoring, the BDX II has rugged and dependable construction that will withstand the toughest industrial environments. The built-in rotometer monitors flow rates over the entire flow range of 0.5 - 3.0 LPM. The electronic flow adjustment enables ports to last longer. The rechargeable NiCAD battery provides approximately 10 hours of reliable operation on a single charge and easily detaches from the pump body for recharging and/or quick field change. A sealed flow adjustment and on/off switch protects the pump from moisture, dust and fibers. The BDX II accurately monitors using the NIOSH Method 7400 or the OSHA reference sampling method. It will also monitor for lead using NIOSH methods 7082, 7105, or 7300.

Part #	Description
801813-120	Air sampler, BDXII Starter kit (includes pump, battery, charger, hose, clip & tool kit)
801813	Air sampler, BDX II pump only



Air-O-Cell™ Cassettes The Air-O-Cell is a unique air sampling cassette specifically designed for the rapid collection of a wide range of airborne aerosols, including mold spores, pollen, insect parts, skin cell fragments, fibers (e.g. asbestos, fiberglass, cellulose, clothing fibers, etc.) and inorganic particulate (e.g. ceramic, fly ash, copy toner, etc.). The Air-O-Cell can be used with any standard off-the-shelf area sampling pump capable of drawing 15 LPM open flow. The small compact size makes Air-O-Cell suitable for use in confined or restrictive spaces.

25mm PCM and TEM Cassettes Zefon offers a complete line of PCM and TEM 25 mm air sampling cassettes designed and manufactured to meet all applicable NIOSH, OSHA, and EPA standards.

- Key benefits:
- 2" Static conductive extension cowl
 - Meets NIOSH specifications
 - Preloaded - ready to use



37mm Cassettes Zefon offers a complete line of 37mm air sampling cassettes manufactured to meet all applicable NIOSH, OSHA, and EPA standards. All 37 mm cassette housings are manufactured in-house from polystyrene and are available in both two and three piece configurations and are ready to use.

- Key benefits:
- Polystyrene Housing, 2 or 3 piece
 - Meets NIOSH requirements



Part #	Description	Quantity
AOC010	Air-O-Cell cassette	10/cs
Z008BA	PCM, 25mm air sampling cassette, 3pc static conductive cowl, 0.8µm MCE filter	50/cs
Z045BA	TEM, 25mm air sampling cassette, 3pc static conductive cowl, 0.45 + 5.0µm MCE filter	50/cs
738MCE	MCE, 37mm air sampling cassette, 3pc polystyrene, 0.8µm filter	50/cs

Omniguard™ III Differential Pressure Recorder

The Omniguard III utilizes state-of-the-art pressure measurement technology to accurately document vacuum and pressure inside a containment area. With features designed to display information clearly and quickly, you'll be confident that you have the best instrument for the job.

FEATURES:

- High and low alarm setpoints
- Configuration report prints current settings and monitoring status for easy review
- Date and time
- Print/log interval adjustable to conserve paper and memory
- Relay output can trigger remote alarm, autodialer or other external device



Part #	Description
ENG515-064	Differential Pressure Recorder
ENG-201-211	Replacement Paper

Environmental Products



#626 - Carpet Adhesive Remover

Sentinel 626 is a powerful, biodegradable formulation designed specifically for quickly removing latex, acrylic and pressure sensitive adhesives from concrete, terrazzo, ceramic and vinyl tile or wood substrates. While 626 works on most latex, acrylic and pressure sensitive adhesives, it is recommended to test a small area first.

#747 - Low Odor Mastic Remover

Sentinel 747™ Low Odor Mastic Remover helps make a professional's job easier. Sentinel 747 saves you time, money, and effort by making quick work of tough mastic removal jobs. Sentinel 747 is the most widely specified, most widely-used product for removing flooring adhesive and mastic. Powerful enough for the toughest jobs, 747's low-odor, completely organic and biodegradable formula quickly liquefies mastic for fast, easy and safe removal. 747 also rinses away completely, leaving floors clean, free of residues, and ready to accept new flooring. Sentinel 747 is the original liquid mastic remover that revolutionized the industry and continues to set today's standards for performance and value. Backed by our guarantee of quality and the finest network of knowledgeable distributors in the business, it's no wonder that Sentinel 747 is the choice of professionals.

#7200 - High Flash Mastic Remover

Sentinel's 7200 is ideal for those situations where conditions make it desirable or consultant specifications make it necessary to use a mastic remover with a flash point over 200 degrees F. In addition, Sentinel 7200 has virtually no odor. It is 100% organic and contains no hazardous citrus or chlorinated solvents. Ask anyone who has used Sentinel 7200 High Flash Mastic Remover and you will find that it delivers consistent performance you can count on every time.

#805 - TSP EnviroWash Detergent

Sentinel 805 EnviroWash is a specially formulated concentrate designed to meet or exceed HUD guidelines as a high-phosphate wash for the final cleanup process in a lead-paint encapsulation or removal project. It has been specially manufactured with emulsifiers which mix soils to be cleaned, sequestering agents to keep soils in solution and rinsing agents so the hazardous residues may be more completely rinsed away.

Part #	Description	Sizes
626	Carpet adhesive remover	5 gal. pail
626-55	Carpet adhesive remover	55 gal. drum
747	Low odor mastic remover	5 gal. pail
747-55	Low odor mastic remover	55 gal. drum
7200	High flash odorless mastic remover	5 gal. pail
7200-55	High flash odorless mastic remover	55 gal. drum
805	EnviroWash	5 gal. pail



#19105 - Control Low Odor Mastic Remover is a safe, active solvent for dissolving asphaltic floor tile mastics and adhesives. The product is a low odor blend of organic hydrocarbons perfect for areas where chemical odors may cause concern. This fast acting formula has a high penetrant content which quickly softens the mastic minutes after complete saturation. In many cases the adhesives can be completely liquefied using a push broom and squeegee with this product. The formula also wets out asbestos fibers preventing them from becoming airborne. Also, the product contains special emulsifiers which aid in tackling difficult to remove floor tile adhesives.

Part #	Description	Sizes
19105	Grayling, CONTROL, Low odor Mastic remover	5 gal. pail
19105-55	Grayling, CONTROL, Low odor Mastic remover	55 gal. drum

Environmental Products



A-B-C® #6421-off white, #6422-clear



When high costs make asbestos removal an unsuitable choice, you can manage asbestos in-place through encapsulation. A-B-C Asbestos Binding Compound, our flagship product, is the world's most successful encapsulation solution. This highly effective, industry-standard, high-solids encapsulant meets Environmental Protection Agency guidelines. It's ideal for sealing in asbestos-containing material, as laboratory tests have shown.

The EPA recommends you apply two coats for maximum effectiveness. Dilute the first coat with water so it can penetrate and bind the asbestos-containing material. Then apply the second coat at full strength.

A-B-C completely encapsulates all fibers beneath a flexible, impact-resistant seal. A-B-C can also be diluted to perform just about any asbestos control task, from encapsulation to pre-removal wetting or room misting to post-removal lockdown of asbestos fibers.



Penewet® #6450-clear

Removing crumbly asbestos-containing material (ACM) can send clouds of fibers and dust billowing into the workplace. Spraying with Penewet eliminates the hazard by wetting the ACM and making it safe to handle.

A surface treated with Penewet stays wet at least 5 times longer than with competitive products. Its chemically advanced wetting/penetrating/binding action saturates the entire mass of ACM. So it's easy to scrape and bag the damp ACM mass material without stirring up dangerous asbestos dust.



Fiberset® PM #7470-white, #7475-clear, #7480-blue

After asbestos is removed, spray Fiberset PM lockdown on the newly exposed beam or deck assembly. One coat of this competitively priced, premixed lockdown traps all microscopic asbestos fibers left on the surface and ensures final air clearance.

Fiberset PM forms a durable barrier that's UL® classified. Its quality formulation ensures ease of sprayability and resists dripping or over spray. Its superior resins bond respray fireproofing securely to decks or beams, and above all, Fiberset PM locks leftover fibers down tight.



Lag-Kloth® #6425-pail

Lag-Kloth uses a fabric incorporating water activated adhesive that forms a flexible barrier. But Lag-Kloth is sized differently. Lag-Kwik is made in 4-inch rolls, while Lag-Kloth comes in two sizes: 5' x 150' rolls or 5' x 15' blankets. This sizing makes Lag-Kloth especially suitable for larger applications.

Example: one piece wrapping over asbestos insulation covering a boiler.



Lag-Kote II® #6420 pail

Lag-Kote II is a bright white bridging encapsulant that is high in solids which provides maximum protection over asbestos containing materials (ACM). Select Lag-Kote II to encapsulate thermal insulation that will not be exposed to rust and/or sunlight.

Lag-Kote II is a high solids encapsulant specifically formulated for application over friable asbestos containing material (ACM). It is ideally suited for encapsulation of pipes, duct work, boiler jackets, breeching and other components of heating and ventilation systems (HVAC/R). It's thick body minimizes dripping, clean-up and product waste while providing a smooth, washable, aesthetically superior finish that will provide years of protection. Lag-Kote II is a flexible coating which can be applied over galvanized metal, wood, masonry or other sound surfaces to prevent release of harmful asbestos fibers. Its bright white finish has excellent hiding power giving it an aesthetically pleasing and professional appearance.

Part #	Description	Sizes
6421-1	A-B-C Asbestos Binding Compound, off white	1 gal.
6421	A-B-C Asbestos Binding Compound, off white	5 gal. pail
6422	A-B-C Asbestos Binding Compound, clear	5 gal. pail
6450	Penewet®, clear	5 gal. pail
7470	Fiberset® PM, white	5 gal. pail
7475	Fiberset® PM, clear	5 gal. pail
7480	Fiberset® PM, blue	5 gal. pail
6425	Lag-Kloth®	5 gal. pail
6420	Lag-Kote II®, white	5 gal. pail
6427	Lag-Kwik Insulation Repair Cloth	5 gal. pail

Environmental Products

PIRANHA®

HIGH PERFORMANCE

INDUSTRIAL PAINT STRIPPERS



When you need fast, effective paint strippers, attack your project with Piranha® paint strippers. Piranha strippers are the most effective chemical paint removers available on the market; no matter what your project needs, Fiberlock has a solution.

*Due to the nature of paint stripping, it is virtually impossible to determine beforehand which Piranha paint remover will work best on a given project. Before any paint stripping project commences, it is important that a test patch is performed to determine which product to use. This will also determine the dwell time for the product to remain active prior to complete system removal. Starting a project before administering a test patch could result in improper product selection and/or usage.



Piranha III #5730-Alkaline Paste

Heavy-duty alkaline paste remover for most paints, including lead-based paint (LBP). Designed for use on most surfaces. Unlike weaker caustics, it is fast-working and needs no evaporation paper to prevent premature drying.

As is true with all caustic paste paint removers, coverage is dependent on the thickness of product applied. Coverage at: 1/4" = 6.4 ft²/gallon, 1/8" = 12.8 ft²/gallon, 1/16" = 25.6 ft²/gallon.

After paint removal, residual Piranha III will need to be neutralized with P-III Neutralizer before the surface is repainted.

Piranha IV #5740-Solvent Gel

Removes multiple layers of most difficult paints and stubborn coatings without the use of dangerous solvents or caustics.

Excellent sag resistance - clings to vertical and overhead surfaces.

Piranha IV effectively removes tough mixed systems of oil and latex paint. Though it is not usually necessary, P-IV Emulsifier will remove any residual Piranha IV.



Piranha V #5750-Alkaline Paste

Formulated specifically for removal of multiple layers of industrial coatings and paint (including red lead) from steel structures (bridges, water towers, etc.). Unlike average caustic paint removers, Piranha V stays wet longer and attacks paint more aggressively- the qualities needed to work effectively on steel in an exterior environment. No methylene chloride or dangerous solvents.

Coverage depends on thickness of application: 1/4" = 6.4 ft²/gallon, 1/8" = 12.8 ft²/gallon, 1/16" = 25.6 ft²/gallon. After paint removal, residual Piranha V will need to be neutralized with P-III Neutralizer before the surface is repainted.



P-III Neutralizer™ #5735-Neutralizer

P-III Neutralizer is an organic solution specifically designed to neutralize surfaces after the application of Piranha III or Piranha V. Pre-mixed solution.

L-B-C® Lead Barrier Compound (Type III-Interior/Exterior)

L-B-C® is a high-solids, elastomeric-thermoplastic, water-based copolymer that meets or exceeds all projected federal, state and local standards for lead-based paint encapsulants. Blended specifically to form a durable and flexible encapsulant barrier between lead-based paint and the environment, L-B-C has been independently tested to the ASTM E-1795 requirements for Category III (Type III-Interior/Exterior) encapsulants. E-1795 is the principle performance standard required, adopted and/or incorporated by reference into lead paint abatement rules and regulations at the federal, state and local levels.

L-B-C has been certified by Massachusetts (No. DL-12362), authorized by the states of Connecticut, Ohio, New York, Maryland, Minnesota, and Colorado. L-B-C is accepted for use in all 50 states. L-B-C has also been classified by Underwriters Laboratories (UL®). L-B-C is environmentally friendly and complies with all federal and state VOC requirements.

L-B-C contains Bitrex®, a bitter tasting, non toxic, anti-ingestant to discourage oral contact with lead paint. The required minimum 7 mil dry film thickness of L-B-C offers unparalleled interior and exterior coverage and economics. In addition, the lower film thickness reduces stress on the existing paint system and maintains architectural detail.



Part #	Description	Sizes
5730	Piranha III, Alkaline paste	5 gal. pail
5740	Piranha IV, Solvent Gel	5 gal. pail
5750	Piranha, V, Alkaline paste	5 gal. pail
5735	P-III, Neutralizer™	5 gal. pail
5801-1	L-B-C Lead Barrier Compound, White	1 gal.
5801	L-B-C Lead Barrier Compound, White	5 gal. pail

Environmental Products



FIBERLOCK. SETTING THE STANDARD, AGAIN.

Fiberlock Technologies, Inc., the leader in asbestos and lead-based paint abatement products, is proud to introduce the brand new **Fiberlock I.A.Q.** line of mold remediation products. This new line offers products to control problematic mold in occupied spaces, and products to prevent reoccurrences of mold outbreaks.

IAQ 2000™-Concentrate/2500-Premixed Cleaner, Disinfectant, Fungicide, Mildewstat

Fiberlock IAQ 2000 and 2500 are EPA registered disinfectants designed to kill and control fungal, bacterial and virucidal growth. Fiberlock IAQ 2000 comes in a economical concentrate that can produce up to 64 gallons of properly diluted cleaner per gallon of concentrate. If on-site dilution is not an option, Fiberlock IAQ 2500 comes ready to use at the proper dilution ratio.

IAQ 3000™-Acrylic Latex Block Filler

Fiberlock IAQ 3000 is a high quality block filler formulated to fill small imperfections and pinholes in masonry block and porous concrete before topcoating. Fiberlock IAQ 3000 is not water sensitive after application, and exhibits excellent flexibility and durability.

IAQ 4000™-Acrylic Latex DTM Primer

Fiberlock IAQ 4000 is a premium water-based, 100% acrylic metal coating for use on ferrous metal, galvanized metal, and other surfaces exposed to general industrial and atmospheric conditions. Fiberlock IAQ 4000 has excellent water resistance and excellent resistance to most alkalis, detergents and mild acids.

IAQ 5000™-Acrylic Latex Stain-Blocking Primer

Fiberlock IAQ 5000 is a quick drying, high performance, 100% acrylic coating designed specifically to prime stained or water damaged surfaces. This premium stain-blocking primer may be used on interior or exterior surfaces to prevent most bleeding type stains, seal porous surfaces and provide adhesion to hard glossy surfaces.

IAQ 6000™-Mold Resistant Coating

Fiberlock IAQ 6000™ is an extremely durable 100% acrylic mold resistant coating developed to withstand moist, humid conditions that provide the ideal environment for fungal growth. Fiberlock IAQ 6000 contains an EPA-registered, broad spectrum fungicide to prevent the growth of mold on the surface of the cured film.

Part #	Description	Sizes
8320	IAQ 2000 Concentrate - Cleaner, Disinfectant, Fungicide, Mildewstat	1 gal.
8325	IAQ 2500 Pre-Mixed - Cleaner, Disinfectant, Fungicide, Mildewstat	5 gal. pail
8330	IAQ 3000 Acrylic Latex Block Filler	5 gal. pail
8340	IAQ 4000 Acrylic Latex DTM Primer	5 gal. pail
8340-55	IAQ 4000 Acrylic Latex DTM Primer	55 gal. drum
8350	IAQ 5000 Acrylic Latex Stain-Blocking Primer	5 gal. pail
8350-55	IAQ 5000 Acrylic Latex Stain-Blocking Primer	55 gal. drum
8360	IAQ 6000 Mold Resistant Coating	5 gal. pail
8360-55	IAQ 6000 Mold Resistant Coating	55 gal. drum



Environmental Products

Porter Interior Primer/Finish

This 100% acrylic, interior primer/finish is used to prime properly prepared unpainted, painted, or varnished wood, drywall, plaster, and masonry. It contains INTERSEPT, an agent that controls the growth of mold and mildew on the surface of the paint film, and can be used as a mildew resistant drywall sealer under wallcoverings. May also be used as a finish on ceilings, closets, storerooms, garages, etc.

Features:

- Superior mold and mildew resistance
- Fast drying
- High hiding
- Low odor
- Excellent adhesion

Benefits:

- Recoat in 1 hour
- Seals drywall under wallcovering
- Multi-use primer/finish
- Easy soap & water cleanup



Part #	Description	Size
3900	Interior Primer/Finish	5 Gal.



Foster 40-20 Fungicidal Protective Coating

FOSTER Fungicidal Protective Coating is a polyacrylate copolymer emulsion specifically formulated for long term fungicidal activity, with no loss of activity on aging. It is formulated to effectively prevent the spread of molds and odor-causing bacteria on its surface. It provides a tough, elastic decorative finish that allows for movement without splitting to create lodging places for bacteria.

FOSTER Fungicidal Protective Coating provides a cost effective decorative finish resistant to many industrial chemicals, together with long-lasting protection. It can be used on walls, ceilings, pipes, interior and exterior surfaces of HVAC duct systems, and wherever effective controls are essential.

FOSTER Fungicidal Protective Coating improves the indoor quality by guarding against the regrowth and proliferation of odor-causing bacteria and molds throughout the building and air handling equipment. As a result, the building occupants may enjoy a work space free of the odor problems often associated with contaminated HVAC duct systems.

Foster 40-80 HVAC & Wall Disinfectant

FOSTER 40-80 HVAC & Wall Disinfectant is a disinfectant-cleaner-fungicide-mildewstat-virucide-deodorizer designed for hospital, institutional, commercial, and industrial use.

40-80 HVAC & Wall Disinfectant is an EPA registered formulation, a full strength disinfectant, and comes in a convenient ready-to-use dilution. 40-80 has been evaluated in the presence of 5% serum by the AOCA Use-Dilution test and found to be effective against a broad spectrum of gram-negative and gram-positive organisms.

40-80 HVAC & Wall Disinfectant offers user safety in that end-users need not work with a corrosive and sometimes dangerous concentrate. 40-80 carries "CAUTION" as a signal safety word.

40-80 HVAC & Wall Disinfectant comes full strength for effective and economical use. Concerns about underdilution or excess material disposal are eliminated.

Part #	Description	Size
40-20	Fungicidal Protecting Coating	5 Gal.
40-80	Disinfectant	5 Gal.

PowerPlus offers a complete line of mold remediation equipment & supplies.

Please contact an

PowerPlus TEAM MEMBER

for additional information or to order our full line mold remediation catalog.

Environmental Products



4460 EXT - The basic Avail extended run glovebag. This economy model enjoys all the features of the Avail line except the entry ports. Encloses pipe insulation diameters up to 8", and can safely contain anywhere from 6.3' to 91' of horizontal pipe. Each of the 25 chambers measures 44" x 60" allowing you to cut off as many as you need. One arm set per chamber, stocked in 6 mil and available in 10 mil special order.



6072 EXT - Larger pipes require glovebags with expanded work areas, the Avail 6072 is your answer. The chamber measures 60" x 72" which encloses pipe insulation diameters up to 14", and can safely contain a 3.5' horizontal work area. One arm set per chamber, stocked in 6 mil and available in 10 mil special order.

Part #	Description	Pack
4460EXT	Grayling, Basic Extended Run glove bag, 6 Mil, for small pipe	25/roll
6072EXT	Grayling, Full Feature Extended Run glove bag, 6 Mil, for larger pipe	20/roll



PLASTIC SHEETING AND BAGS

Part #	Description	Pack
PLY1020C	Poly Sheeting, clear, 10 Mil, 20' x 100'	roll
PLY320C	Poly Sheeting, clear, 3 Mil, 20' x 100'	roll
PLY408C	Poly Sheeting, clear, 4 Mil, 8' x 100'	roll
PLY410C	Poly Sheeting, clear, 4 Mil, 10' x 100'	roll
PLY412C	Poly Sheeting, clear, 4 Mil, 12' x 100'	roll
PLY420B	Poly Sheeting, black, 4 Mil, 20' x 100'	roll
PLY420C	Poly Sheeting, clear, 4 Mil, 20' x 100'	roll
PLY420FR	Poly Sheeting, flame retardant, 4 Mil, 20' x 100'	roll
PLY610C	Poly Sheeting, clear, 6 Mil, 10' x 100'	roll
PLY610FR	Poly Sheeting, flame retardant, 6 Mil, 10' x 100'	roll
PLY612C	Poly Sheeting, clear, 6 Mil, 12' x 100'	roll
PLY612FR	Poly Sheeting, flame retardant, 6 Mil, 12' x 100'	roll
PLY620B	Poly Sheeting, black, 6 Mil, 20' x 100'	roll
PLY620C	Poly Sheeting, clear, 6 Mil, 20' x 100'	roll
PLY620FR	Poly Sheeting, flame retardant, 6 Mil, 20' x 100'	roll
PLY640C	Poly Sheeting, clear, 6 Mil, 40' x 100'	roll
BAG33663C	Bag, general debris, 3 mil, 38" x 60"	50/roll
BAG43660C	Bag, general debris, 4 mil, 36" x 60"	50/roll
BAG63040C	Bag, general debris, 6 mil, 30" x 40"	100/roll
BAG63860C	Bag, general debris, 6 mil, 38" x 60"	50/roll
BAGAB3040C	Bag, DANGER ASBESTOS, 30" x 40"	100/roll
BAGAB3350C	Bag, DANGER ASBESTOS, 33" x 50"	75/roll
BAGAB3660C	Bag, DANGER ASBESTOS, 36" x 60"	50/roll
BAGAB63040C	Bag, DANGER ASBESTOS, 6 mil 30" x 40"	100/roll
BAGAB63350C	Bag, DANGER ASBESTOS, 6 mil 33" x 50"	75/roll
BAGAB63860C	Bag, DANGER ASBESTOS, 6 mil 38" x 60"	50/roll
BAGDT20-500C	Poly Tubing, 20" x 500', clear	roll

Environmental Products



PowerPlus CLOTH RAGS & WIPERS

PowerPlus offers a wide variety of cloth rags for quick economical cleanup. From light sheeting to absorbent sweatshirt fabric, we have the rag to get the job done. Use to clean countertops, machinery, tools, or to wipe up spills. Ask our experienced sales staff for more information.



Part #	Description	Pack
BTC	Barrier tape, CAUTION, yellow, 3" x 1000'	roll
BTCC	Barrier tape, CAUTION CUIDADO, yellow, 3" x 1000' English & Spanish	roll
BTPD	Barrier tape, DANGER, red, 3" x 1000'	roll
BTPDDNE	Barrier tape, DANGER DO NOT ENTER, red, 3" x 1000'	roll
BTPDAR	Barrier tape, DANGER ASBESTOS, red 3" x 1000'	roll
BTPDARWB	Barrier tape, DANGER ASBESTOS, red/black/white, 3" x 1000'	roll
324B	PowerPlus, duct tape, 3", blue	16/cs.
214S-3	PowerPlus, duct tape, 3", silver	16/cs.
224B	PowerPlus, duct tape, 2", blue	24/cs.
214S	PowerPlus, duct tape, 2", silver	24/cs.
TYC105	Tape, double-sided 2" x 25 yards	24/cs.
TYC530-2	Tape, flatback 2"	24/cs.
TYC530-3	Tape, flatback 3"	16/cs.
LMH-17	Heavy duty spray adhesive	12/cs.
RAGSW25	Wiping rag, sweats	25 lbs
RAGSW50	Wiping rag, sweats	50 lbs
RAGCK25	Colored knit, kags	25 lbs
RAGCK50	Colored knit, kags	50 lbs
RAGCC25	Mixed cotton kags	25 lbs
RAGCC50	Mixed cotton kags	50 lbs
RAGTS25	T-Shirt rags	25 lbs
RAGPR25	Paint Rag, white	25 lbs
RAGCF50	Colored fleece rags	50 lbs
SBT-15	Disposable towels	300/cs.

Environmental Products



Item	Part #	Description	Pack
A	44-1144	Wallscraper, 12" handle, 4" blade	each
-	44-0420	Wallscraper replacement blade 4", 10 per tube	tube
B	25-3503-1	Knife, snap blade, heavy duty, 8 point	each
C	33-7701	Putty Knife, 1 1/4" stiff	each
D	33-7709	Tape Knife, 6" flexible, nail set	each
E	86-1012	Scraper, 3" heavy duty, bent blade	each
F	33-1106	Tape Knife, 6" flexible	each
G	33-7703	Putty Knife, 2" stiff	each
H	RF307	Floor Scraper, heavy duty, 7" blade	each
-	RF307-RB	Replacement Blade, 7"	each
-	303-1	Replacement Blade, 3"	each
I	T50	Staple Gun Tacker, all purpose, heavy duty	each
J	T50-5/16	Staples, T50, 1250/bx	box
-	T50-3/8	Staples, T50, 1250/bx	box
-	T50-1/2	Staples, T50, 1250/bx	box
K	LAG423	Siphon Drum Pump, 15-30- and 55 gallon drums	each
L	AS703	Sprayer, 3 gallon, polyethylene	each
M	3M8550	Stripping Pad, high productivity, 10 per box	box
-	3M6472	Pad Holder	each

PowerPlus
OFFERS A COMPLETE LINE
OF HAND TOOLS

Application for Credit

**FINANCING
APPLICATION**



Date: _____

1525 Endeavour Place #O Anaheim Ca.92801
Phone 714-635-9264 Fax 714-635-9442
www.PowerPlusOnline.com

Tell us about your company:

Legal Name: _____ County: _____
Bus. Mailing Address: _____ Bus. Phone # () _____
_____ Fax #: () _____
Type of Business: _____ Proprietorship _____ Partnership _____ Corporation _____ LLC Cell #: () _____
What is your Federal ID # ? _____ What is your D&B # ? _____

Tell us about the ownership of your company:

The Full Name of the Primary Owner : _____
My Title is: _____ Owner _____ Partner _____ President _____ Member I Own _____ % of this business.
Owner #1 Home Address : _____ Soc. Sec. # _____ - _____ - _____
_____ Home Phone # () _____
The Full Name of the Second Owner : _____
My Title is: _____ Owner _____ Partner _____ President _____ Member I Own _____ % of this business.
Owner #1 Home Address : _____ Soc. Sec. # _____ - _____ - _____
_____ Home Phone # () _____

Tell us about the Bank and Credit References of your company:

Our Primary Business Checking/Savings Account : (Name of Bank) _____
Account Number: _____ Bank Phone # : () _____ Officer's Name: _____
Our Best Business Credit Line is with: (Name of Company or Bank) _____
Account Number: _____ Phone Number: () _____ Contact Name: _____
Our Second Best Business Credit Line is with: (Name of Company or Bank) _____
Account Number: _____ Phone Number: () _____ Contact Name: _____

What Equipment do you want and whom do you want to get it from?

We need the following equipment: _____ At a cost of: \$ _____
We want to get this equipment from: (Name of Vendor) _____ Phone # () _____

Credit Review Authorization

By signing below, the undersigned individual(s) who is either a principal of the credit applicant or a personal guarantor of its obligations, provides written instructions to Agency Capital Corp. or its designees (and any assignee or potential signee thereof) authorizing review of his/her personal credit profile from a national credit bureau. Such authorization shall extend to obtaining a credit profile in considering this application and subsequently for the purposes of update, renewal or extension of such credit and for reviewing or collecting the resulting account. A Photostat or facsimile copy of this authorization shall be valid as the original. By signature below, I/we affirm my/our identity as the respective individual(s) identified in the above application.

Signature:	Signature:
Print Name:	Print Name:
Date:	Date:



Services Offered

- 24 Hour Emergency Service
- Product Sourcing
- Hot Shot Deliveries
- Same Day Deliveries
- Respirator Fit Testing
- Safety Training
- Sight Conservation
- Integrity
- Courteous Staff
- Knowledgeable Staff
- Proper Lifting
- Hearing Conservation
- Local Deliveries
- Extensive Inventories